

circuit diagram

Hanse 460

Cable colors unless otherwise noted:

red (rd): DC +

black (bk): DC -

brown (br): AC L

blue (bl): AC N

green/yellow (gn/ye): AC Ground

All cable cross-sections unless otherwise noted: 1,5mm²

03	bp alarm added, watermaker updated	27.06.2022	DW	Datum	21.06.2021
02	changes solar panels; bathing platform	27.01.2022	JT	Gezeichnet	JTaubert
01	changes AC panel, battery protection, many changes	19.11.2021	JT	Geprüft	JTaubert
Rev.	Änderung	Datum	Name	Genehmigt	JTaubert



Hanse Yachts AG
Ladebower Chaussee 11
17493 Greifswald

Cover Sheet

Hanse 460

H20B-7215-100-010 -03

Blatt: 1
von 54 Bl.

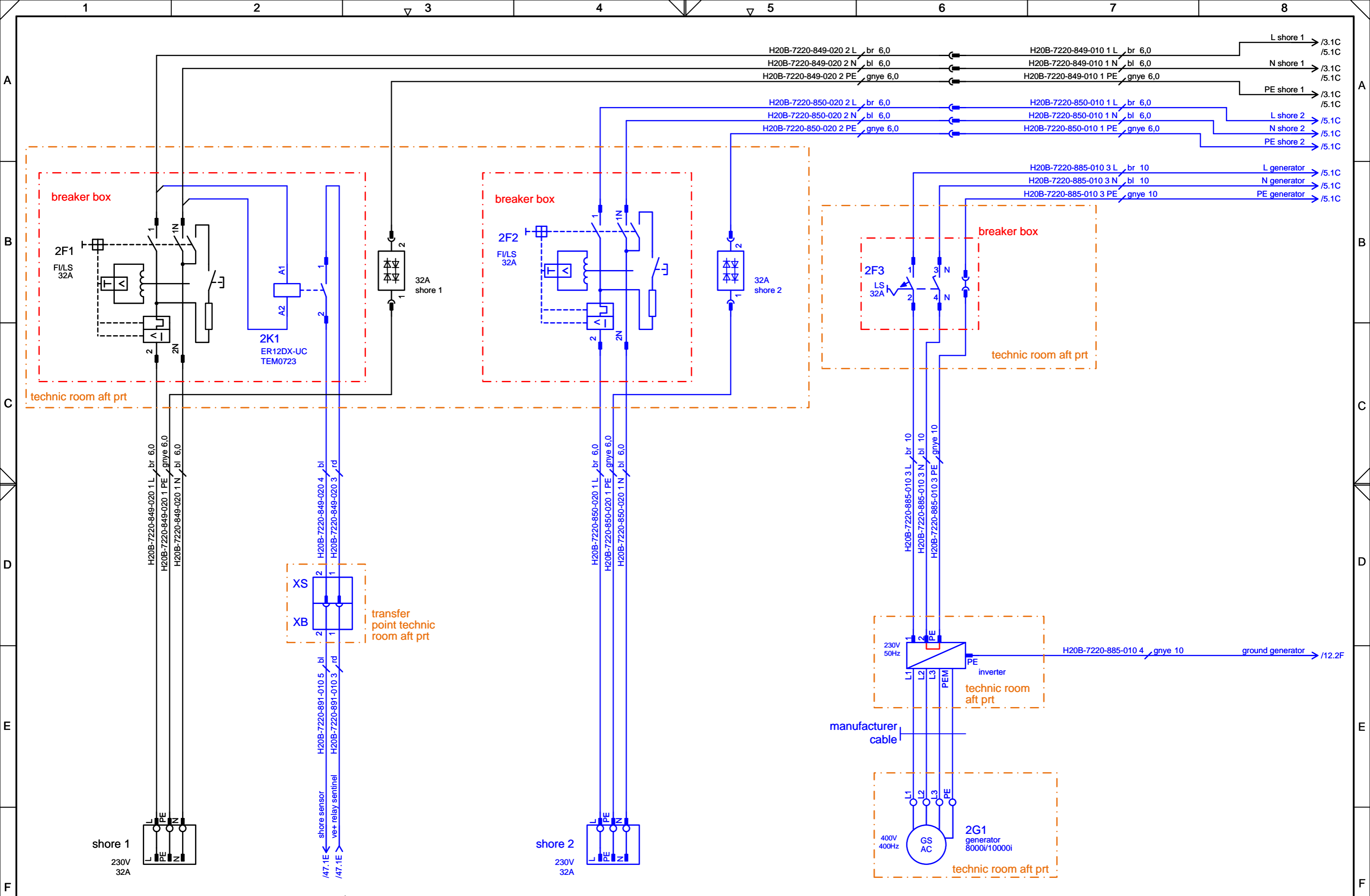

03	bp alarm added, watermaker updated	27.06.2022	DW	Datum	21.06.2021
02	changes solar panels; bathing platform	27.01.2022	JT	Gezeichnet	JTaubert
01	changes AC panel, battery protection, many changes	19.11.2021	JT	Geprüft	JTaubert
Rev.	Änderung	Datum	Name	Genehmigt	JTaubert



 Hanse Yachts AG
 Ladebower Chaussee 11
 17493 Greifswald

AC Circuits
shore power, AC generator

Hanse 460		H20B-7215-100-010 -03		Blatt: 2
				von 54 Bl.

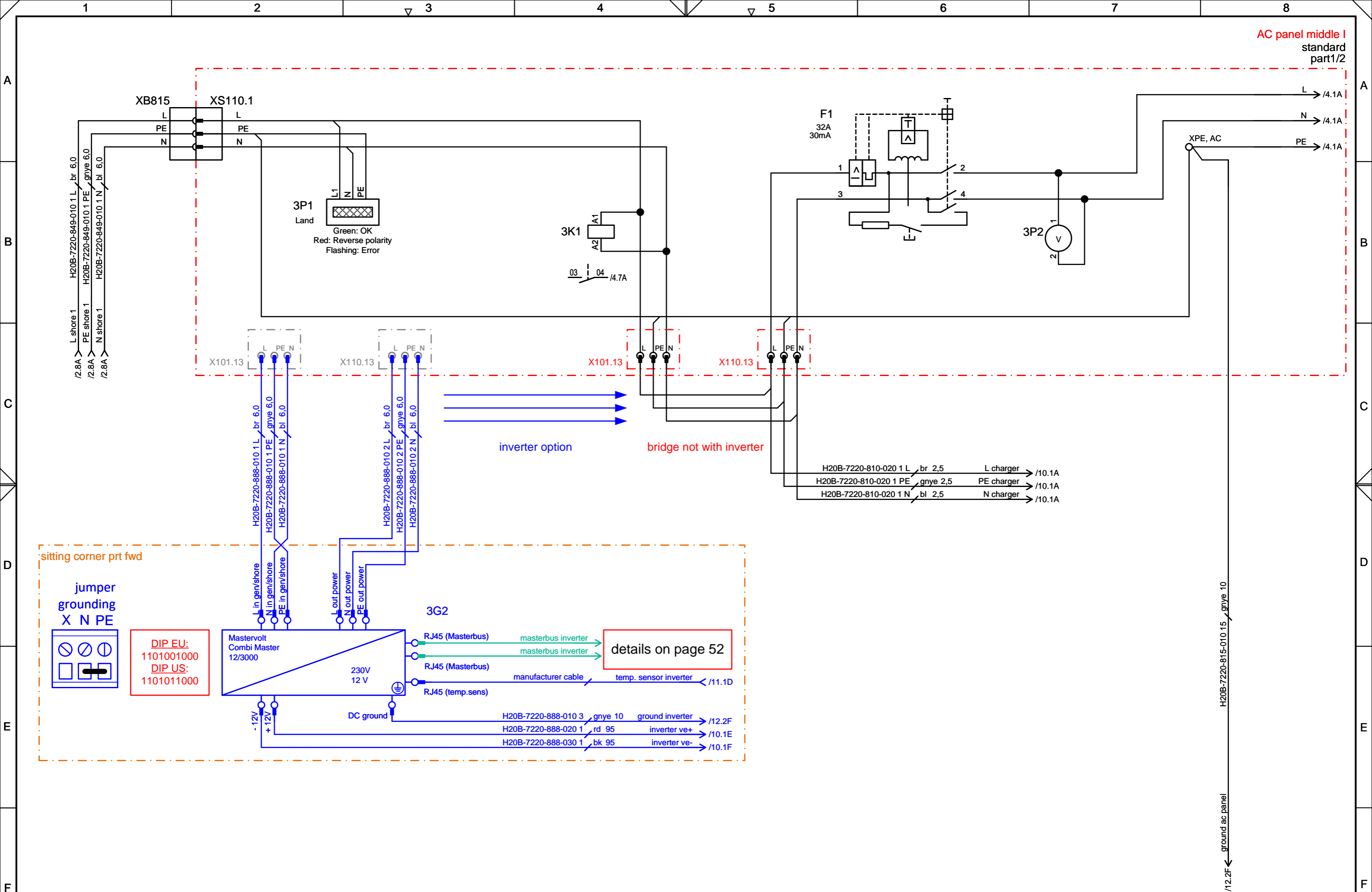

AC panel middle I
standard
part1/2

inverter option
bridge not with inverter

sitting corner prt fwd



DIP EU:
1101001000
DIP US:
1101011000

details on page 52

03	bp alarm added, watermaker updated	27.06.2022	DW	Datum	21.06.2021
02	changes solar panels; bathing platform	27.01.2022	JT	Gezeichnet	JTaubert
01	changes AC panel, battery protection, many changes	19.11.2021	JT	Geprüft	JTaubert
Rev.	Änderung	Datum	Name	Genehmigt	JTaubert



Hanse Yachts AG
Ladebower Chaussee 11
17493 Greifswald

AC Circuits
AC panel standard part 1, inverter

Hanse 460	H20B-7215-100-010 -03	Blatt: 3
		von 54 Bl.

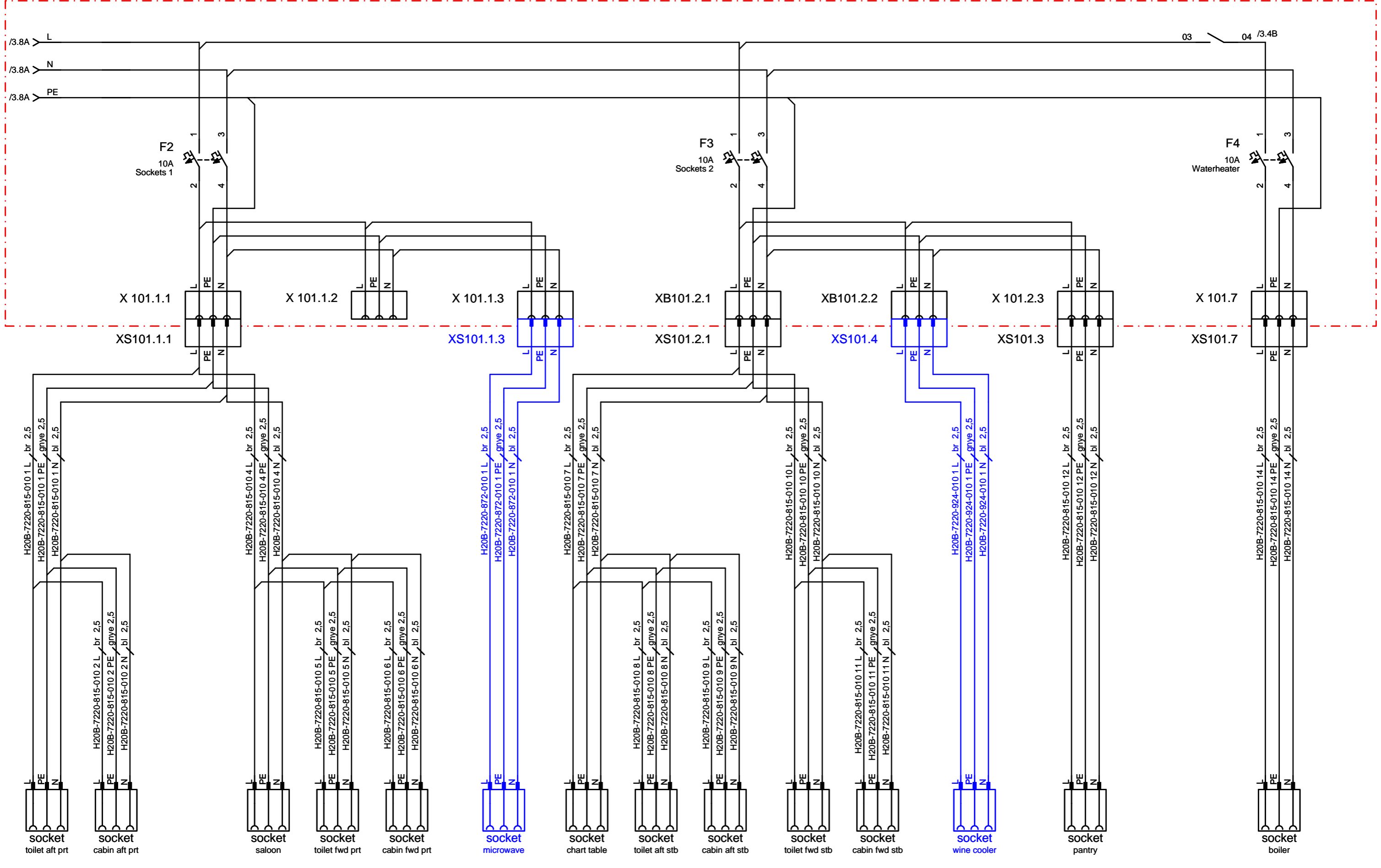

03	bp alarm added, watermaker updated	27.06.2022	DW	Datum	21.06.2021
02	changes solar panels; bathing platform	27.01.2022	JT	Gezeichnet	JTaubert
01	changes AC panel, battery protection, many changes	19.11.2021	JT	Geprüft	JTaubert
Rev.	Änderung	Datum	Name	Genehmigt	JTaubert



Hanse Yachts AG
Ladebower Chaussee 11
17493 Greifswald

AC Circuits
AC panel standard part 2

=		Blatt: 4
+		
Hanse 460	H20B-7215-100-010 -03	von 54 Bl.

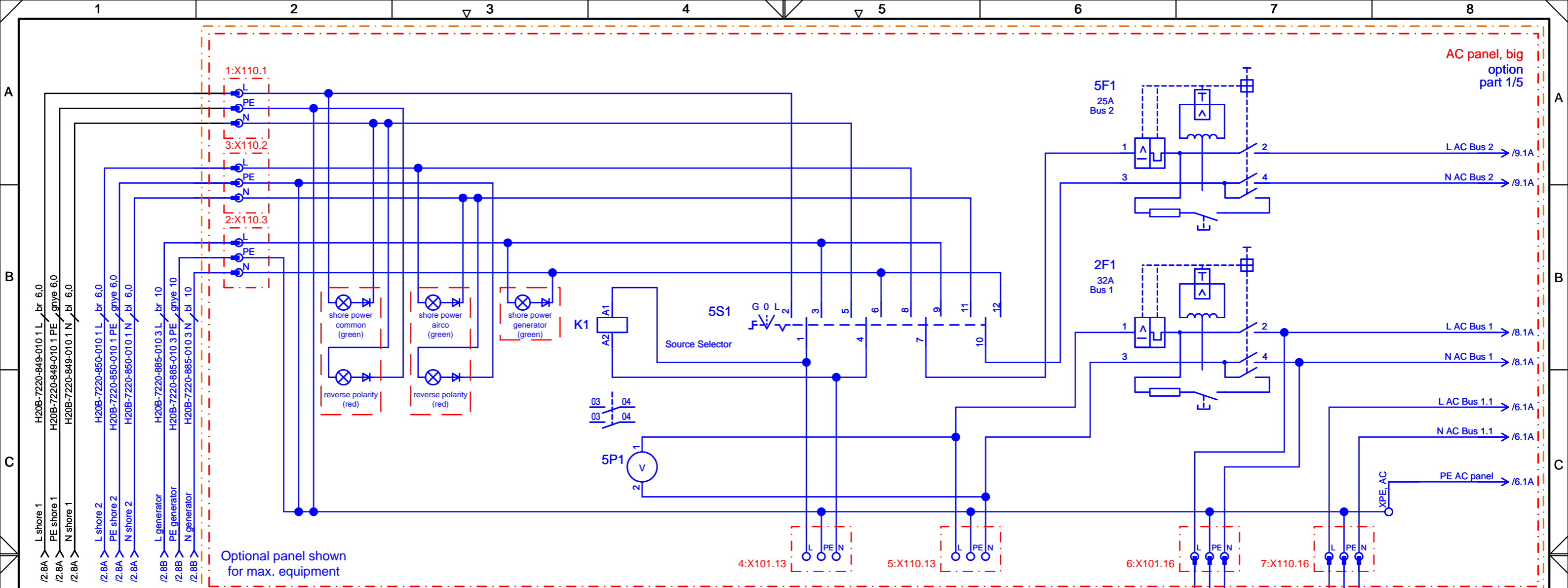

pantry stb

for connection see page 4

03	bp alarm added, watermaker updated	27.06.2022	DW	Datum	21.06.2021	 Hanse Yachts AG Ladebower Chaussee 11 17493 Greifswald	AC Circuits AC panel option part 1	Hanse 460	H20B-7215-100-010 -03	Blatt: 5 von 54 Bl.
02	changes solar panels; bathing platform	27.01.2022	JT	Gezeichnet	JTaubert					
01	changes AC panel, battery protection, many changes	19.11.2021	JT	Geprüft	JTaubert					
Rev.	Änderung	Datum	Name	Genehmigt	JTaubert					

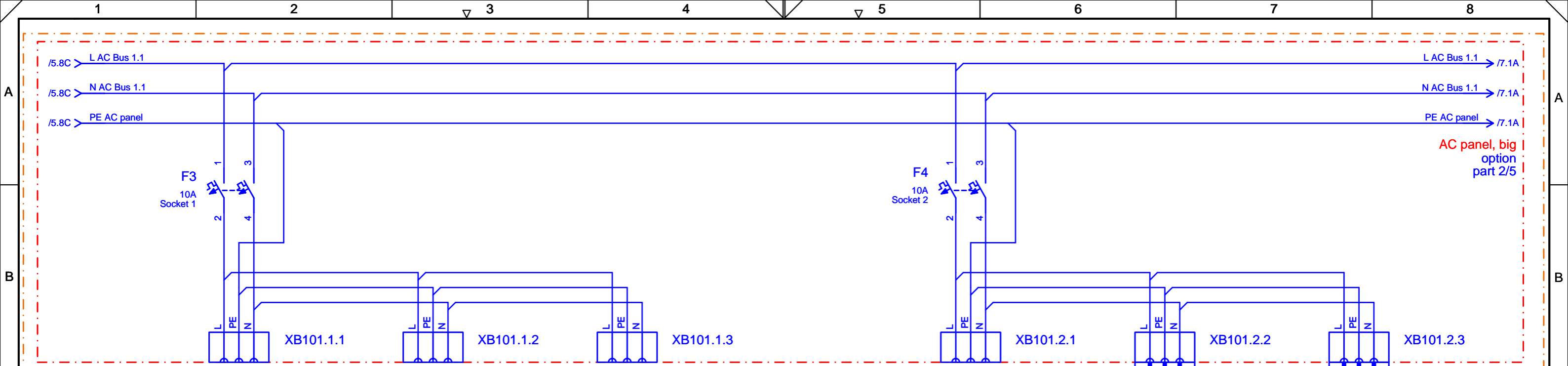

for connection see page 4

for connection see page 4

for connection see page 4

pantry stb

03	bp alarm added, watermaker updated	27.06.2022	DW	Datum	21.06.2021	 Hanse Yachts AG Ladebower Chaussee 11 17493 Greifswald	AC Circuits AC panel option part 2	= +	Hanse 460	H20B-7215-100-010 -03	Blatt:	6	
02	changes solar panels; bathing platform	27.01.2022	JT	Gezeichnet	JTaubert						von	54	Bl.
01	changes AC panel, battery protection, many changes	19.11.2021	JT	Geprüft	JTaubert								
Rev.	Änderung	Datum	Name	Genehmigt	JTaubert								

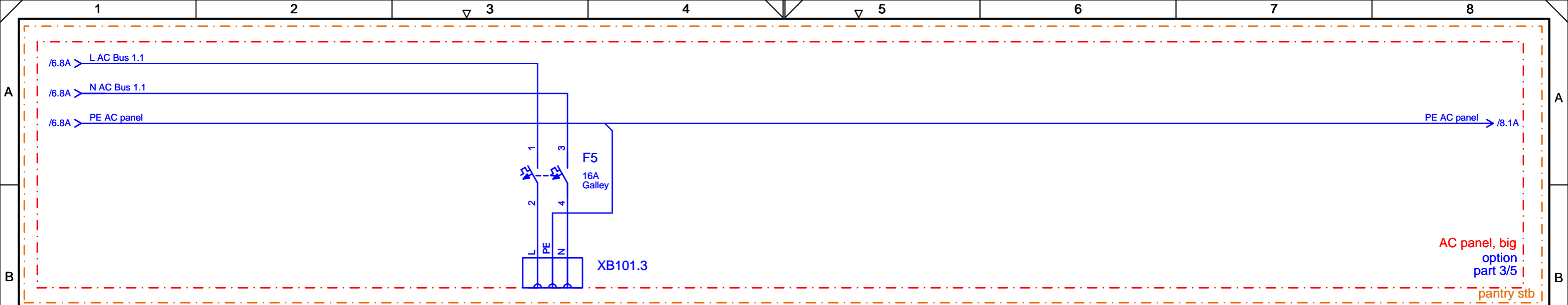

for connection see page 4

03	bp alarm added, watermaker updated	27.06.2022	DW	Datum	21.06.2021		Hanse Yachts AG Ladebower Chaussee 11 17493 Greifswald	AC Circuits AC panel option part 3	= +	Hanse 460	H20B-7215-100-010 -03	Blatt: 7	
02	changes solar panels; bathing platform	27.01.2022	JT	Gezeichnet	JTaubert							von 54	Bl.
01	changes AC panel, battery protection, many changes	19.11.2021	JT	Geprüft	JTaubert								
Rev.	Änderung	Datum	Name	Genehmigt	JTaubert								

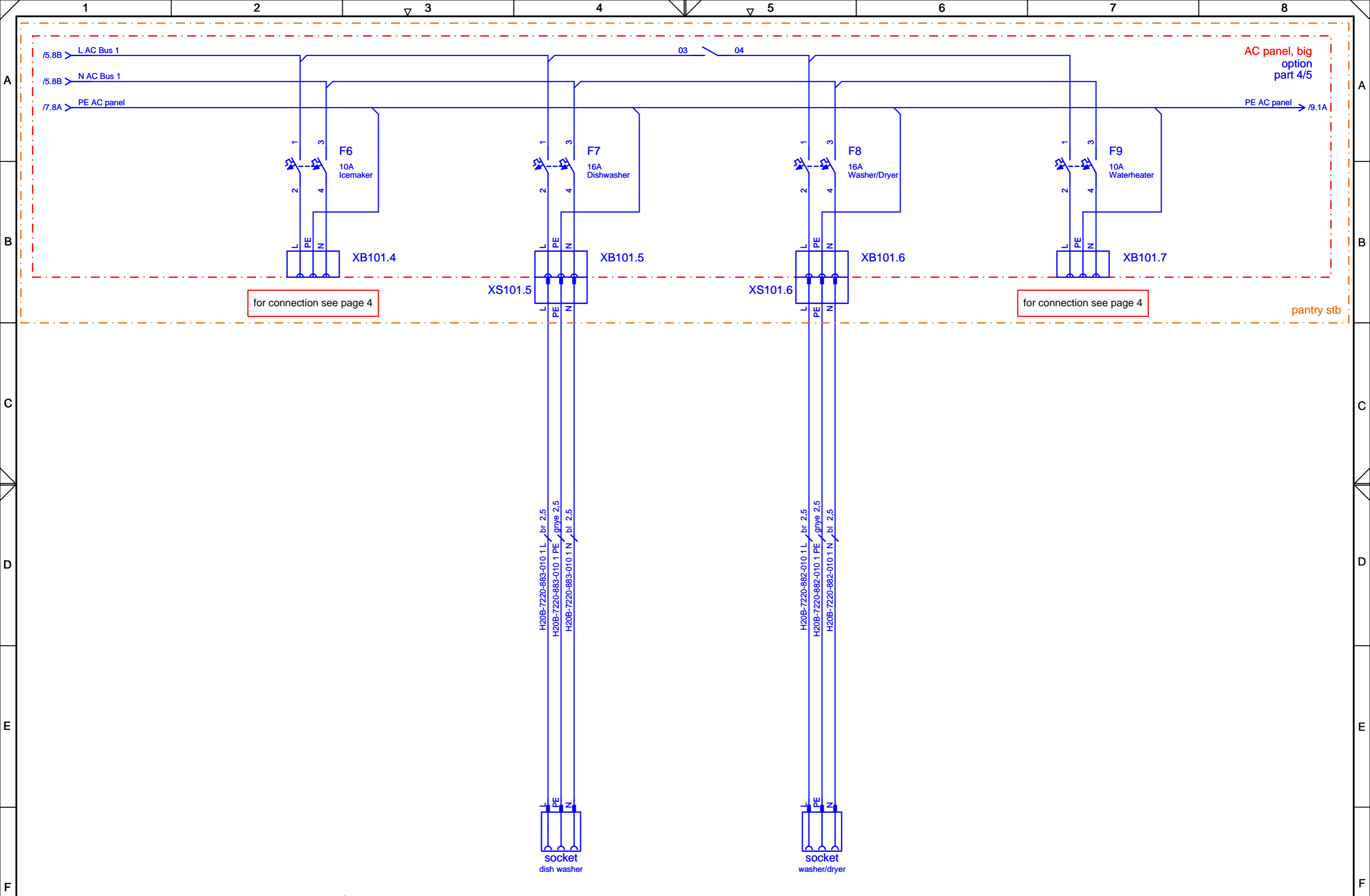

03	bp alarm added, watermaker updated	27.06.2022	DW	Datum	21.06.2021
02	changes solar panels; bathing platform	27.01.2022	JT	Gezeichnet	JTaubert
01	changes AC panel, battery protection, many changes	19.11.2021	JT	Geprüft	JTaubert
Rev.	Änderung	Datum	Name	Genehmigt	JTaubert



Hanse Yachts AG
Ladebower Chaussee 11
17493 Greifswald

AC Circuits
AC panel option part 4

Hanse 460		H20B-7215-100-010 -03		Blatt: 8
				von 54 Bl.

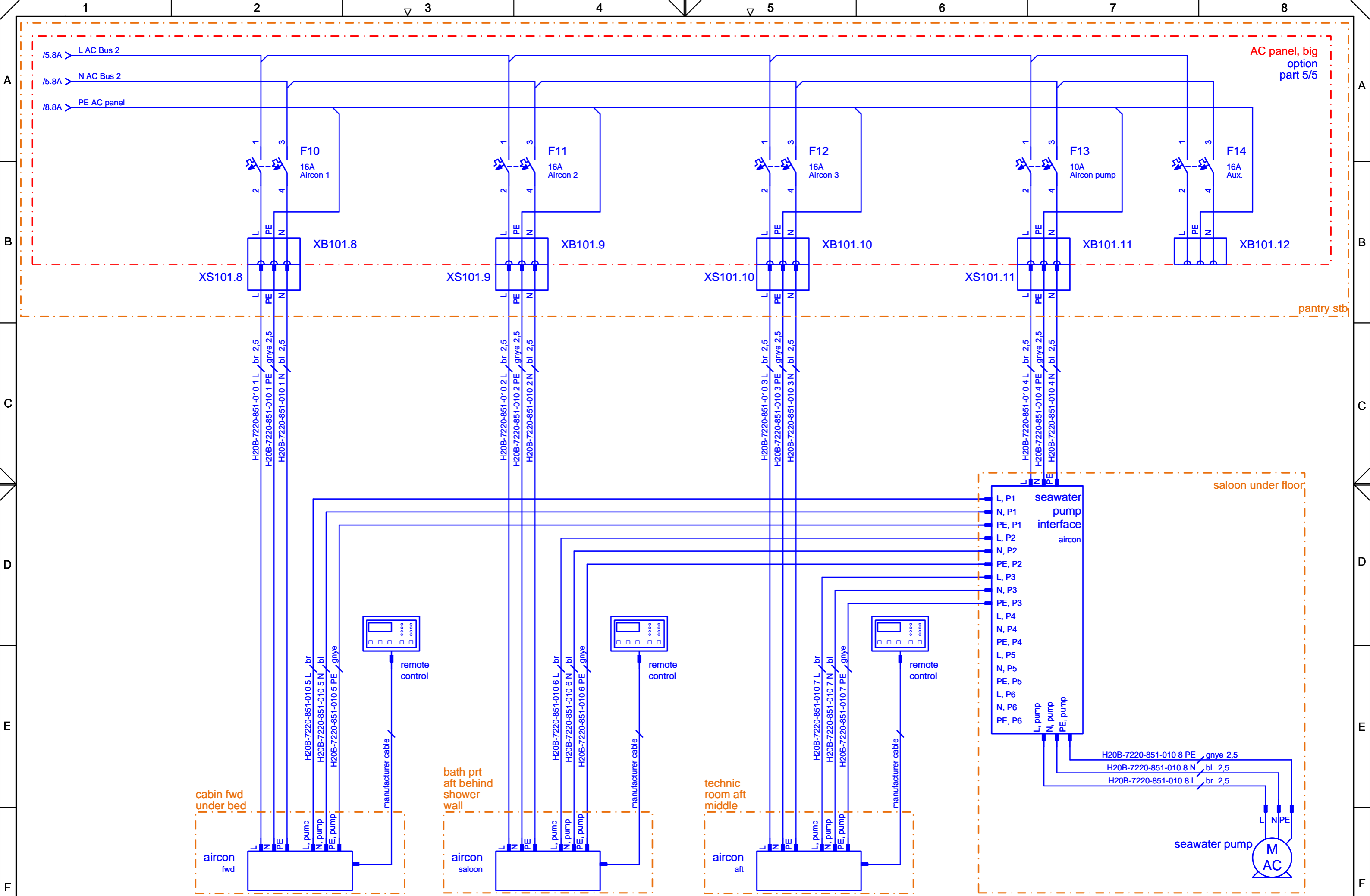

03	bp alarm added, watermaker updated	27.06.2022	DW	Datum	21.06.2021
02	changes solar panels; bathing platform	27.01.2022	JT	Gezeichnet	JTaubert
01	changes AC panel, battery protection, many changes	19.11.2021	JT	Geprüft	JTaubert
Rev.	Änderung	Datum	Name	Genehmigt	JTaubert

 Hanse Yachts AG
 Ladebower Chaussee 11
 17493 Greifswald

AC Circuits
AC panel option part 5

Hanse 460	H20B-7215-100-010 -03	Blatt: 9
		von 54 Bl.

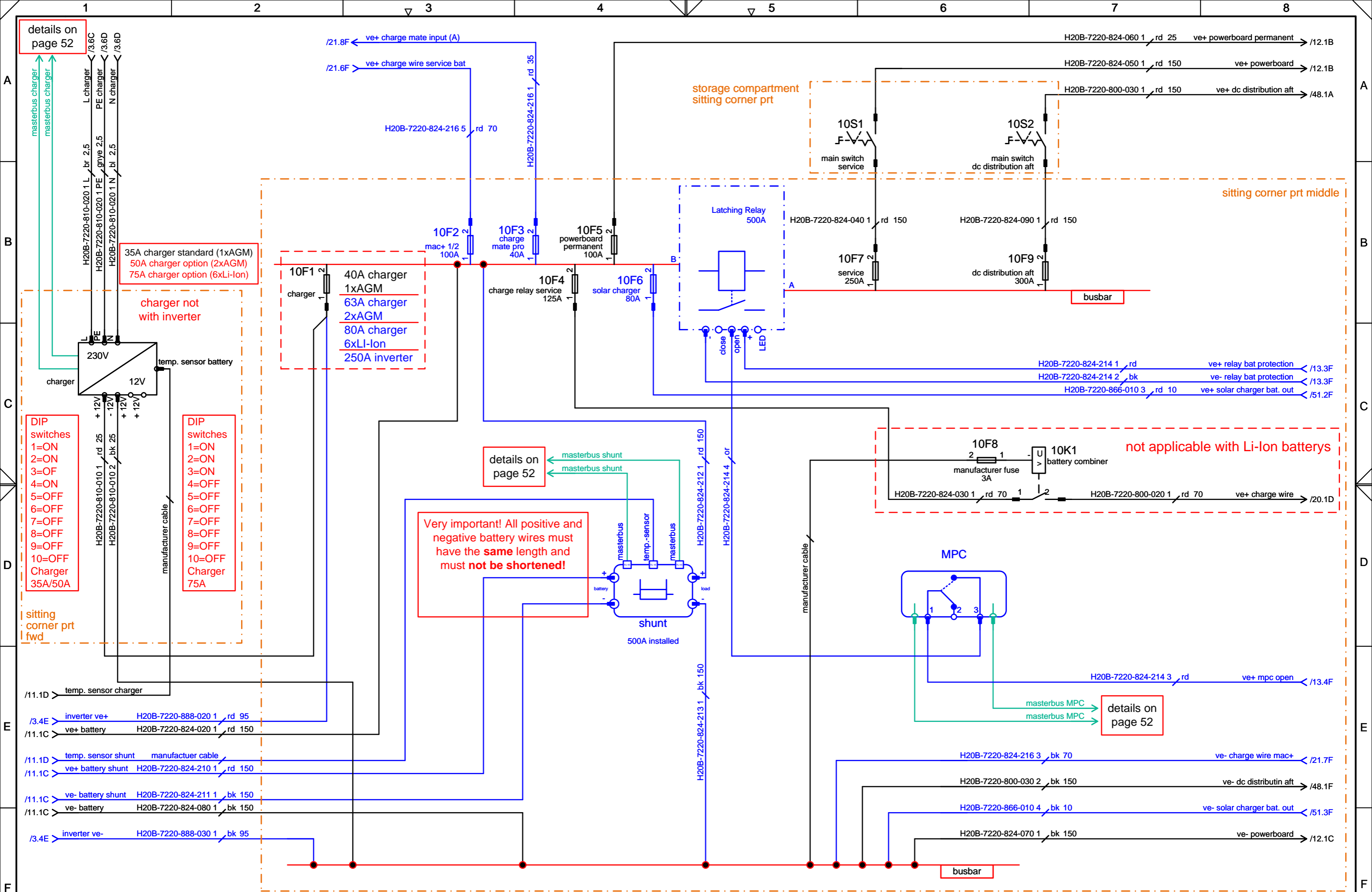

details on page 52

35A charger standard (1xAGM)
50A charger option (2xAGM)
75A charger option (6xLi-Ion)

DIP switches
1=ON
2=ON
3=OFF
4=ON
5=OFF
6=OFF
7=OFF
8=OFF
9=OFF
10=OFF
Charger
35A/50A

DIP switches
1=ON
2=ON
3=ON
4=OFF
5=OFF
6=OFF
7=OFF
8=OFF
9=OFF
10=OFF
Charger
75A

Very important! All positive and negative battery wires must have the same length and must not be shortened!

not applicable with Li-Ion batteries

details on page 52

03	bp alarm added, watermaker updated	27.06.2022	DW	Datum	21.06.2021
02	changes solar panels; bathing platform	27.01.2022	JT	Gezeichnet	JTaubert
01	changes AC panel, battery protection, many changes	19.11.2021	JT	Geprüft	JTaubert
Rev.	Änderung	Datum	Name	Genehmigt	JTaubert



Hanse Yachts AG
Ladebower Chaussee 11
17493 Greifswald

DC Circuits
DC busbar, charger, shunt

Hanse 460		H20B-7215-100-010 -03		Blatt: 10
				von 54 Bl.

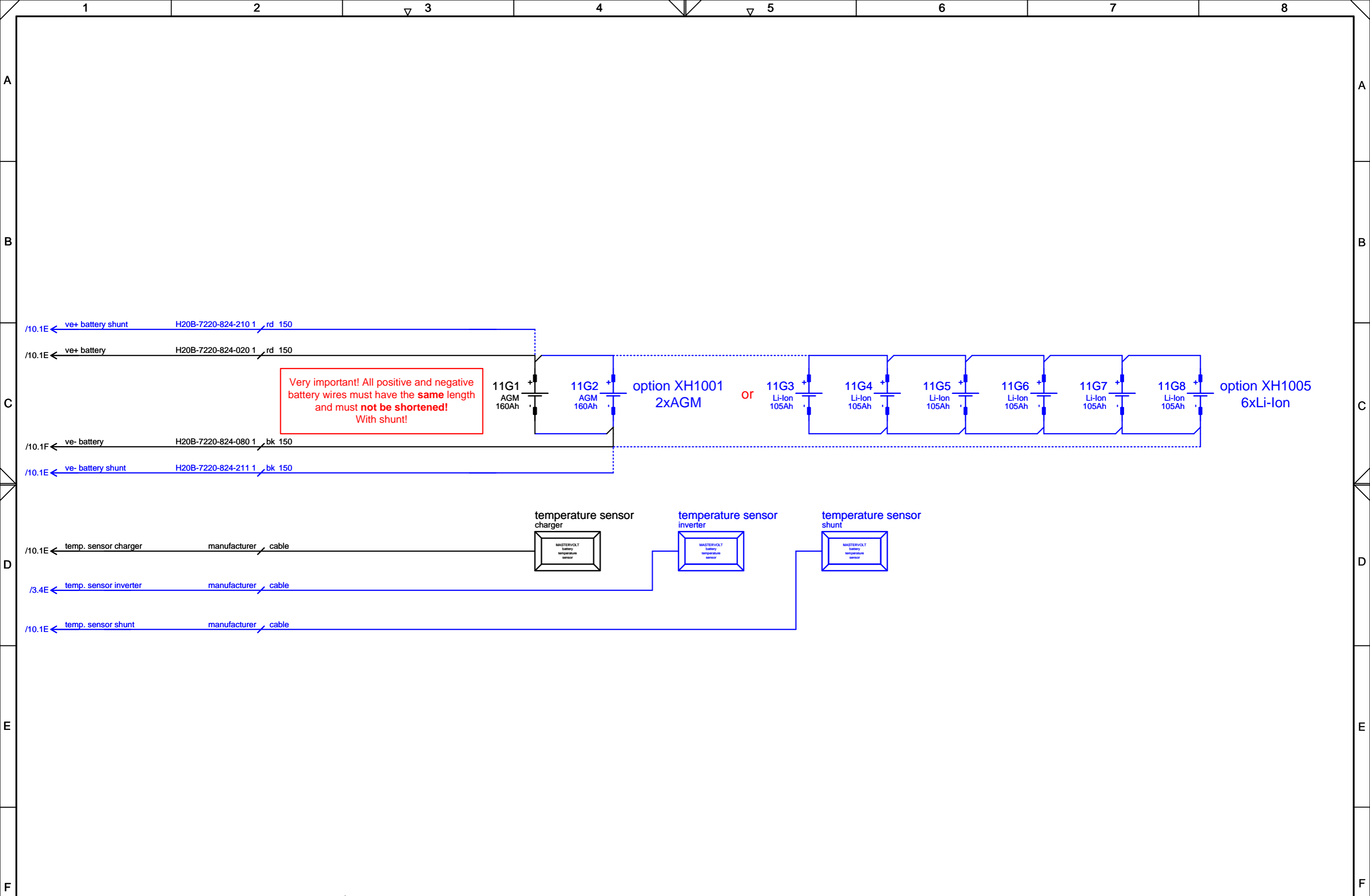

03	bp alarm added, watermaker updated	27.06.2022	DW	Datum	21.06.2021
02	changes solar panels; bathing platform	27.01.2022	JT	Gezeichnet	JTaubert
01	changes AC panel, battery protection, many changes	19.11.2021	JT	Geprüft	JTaubert
Rev.	Änderung	Datum	Name	Genehmigt	JTaubert



Hanse Yachts AG
Ladebower Chaussee 11
17493 Greifswald

DC Circuits
service batteries

Hanse 460		H20B-7215-100-010 -03		Blatt: 11
				von 54 Bl.

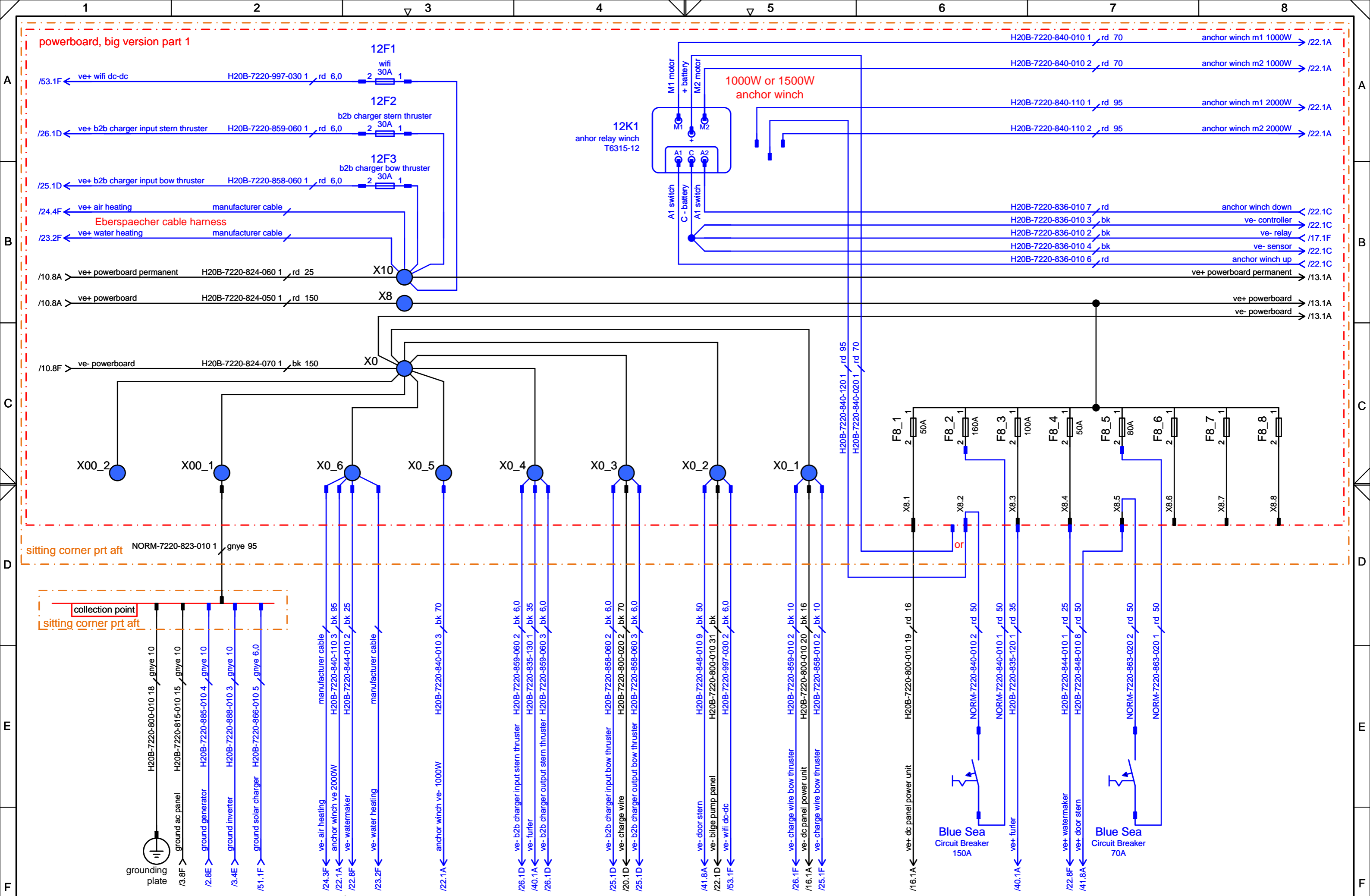

powerboard, big version part 1

1000W or 1500W
anchor winch

sitting corner prt aft

collection point
sitting corner prt aft

03	bp alarm added, watermaker updated	27.06.2022	DW	Datum	21.06.2021
02	changes solar panels; bathing platform	27.01.2022	JT	Gezeichnet	JTaubert
01	changes AC panel, battery protection, many changes	19.11.2021	JT	Geprüft	JTaubert
Rev.	Änderung	Datum	Name	Genehmigt	JTaubert

Hanse
Hanse Yachts AG
Ladebower Chaussee 11
17493 Greifswald

DC Circuits
powerboard part 1

Hanse 460		H20B-7215-100-010 -03		Blatt: 12
				von 54 Bl.

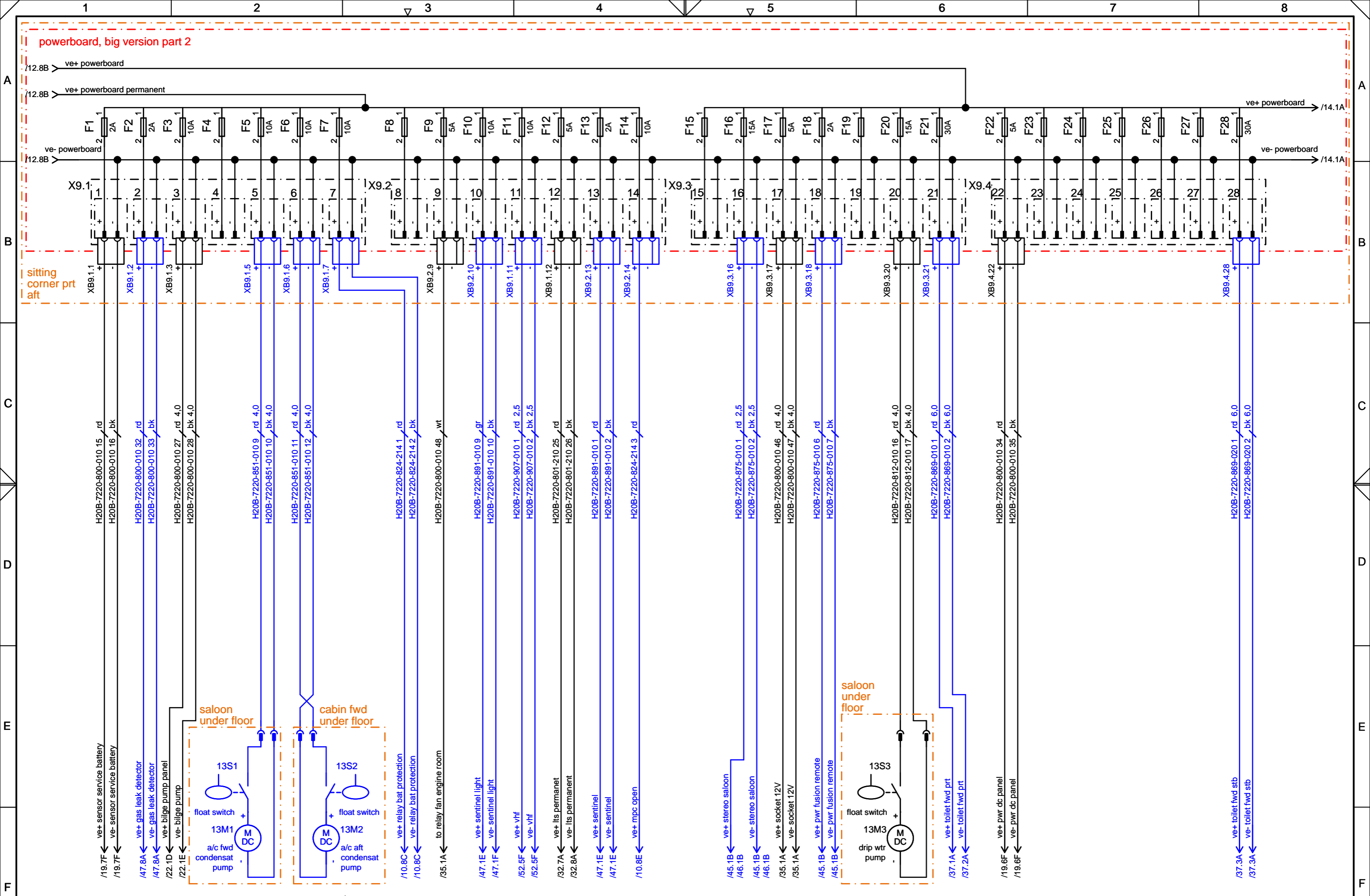

03	bp alarm added, watermaker updated	27.06.2022	DW	Datum	21.06.2021
02	changes solar panels; bathing platform	27.01.2022	JT	Gezeichnet	JTaubert
01	changes AC panel, battery protection, many changes	19.11.2021	JT	Geprüft	JTaubert
Rev.	Änderung	Datum	Name	Genehmigt	JTaubert



Hanse Yachts AG
Ladebower Chaussee 11
17493 Greifswald

DC Circuits
powerboard part 2

Hanse 460		H20B-7215-100-010 -03		Blatt: 13
				von 54 Bl.

powerboard, big version part 3

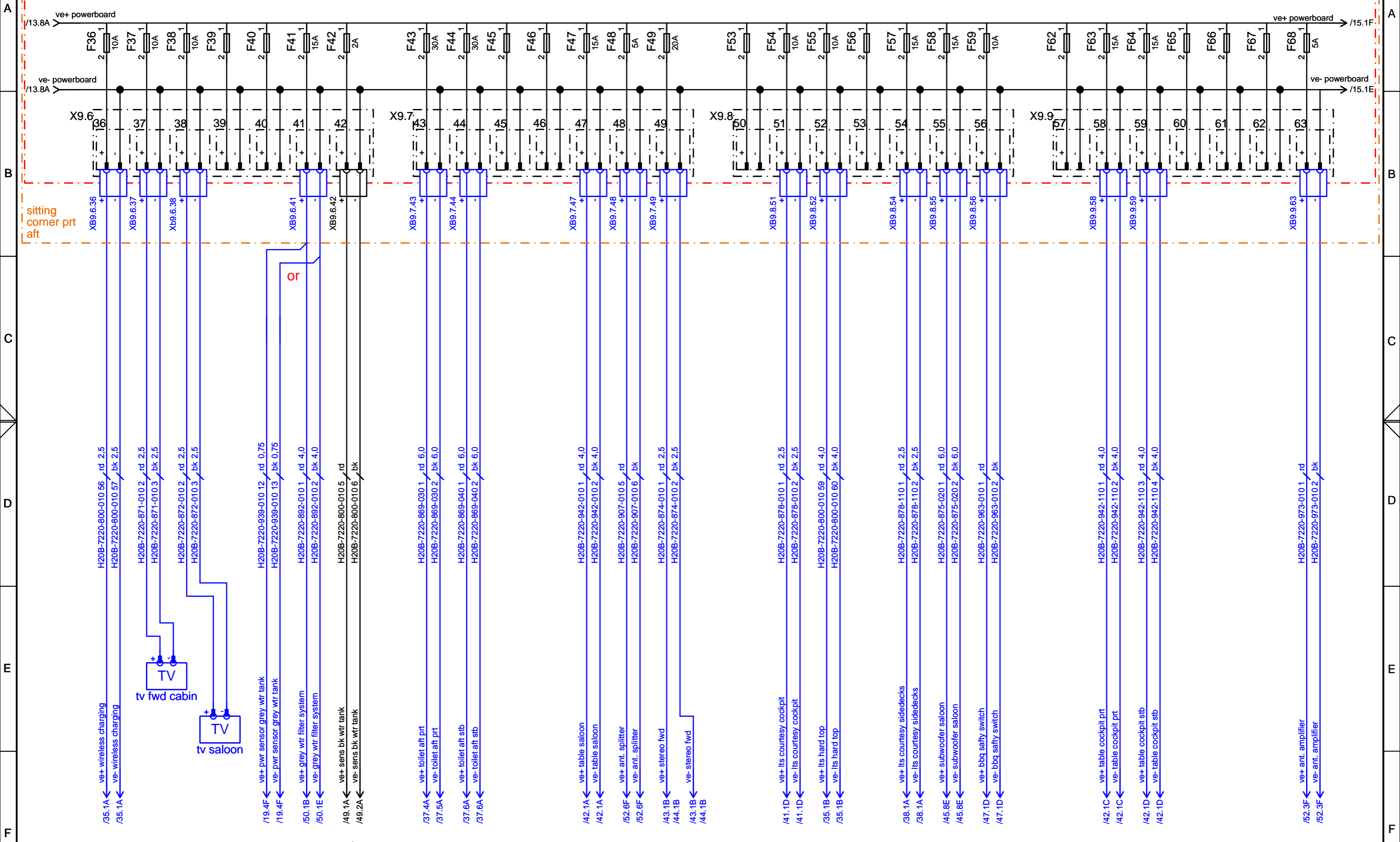

03	bp alarm added, watermaker updated	27.06.2022	DW	Datum	21.06.2021
02	changes solar panels; bathing platform	27.01.2022	JT	Gezeichnet	JTaubert
01	changes AC panel, battery protection, many changes	19.11.2021	JT	Geprüft	JTaubert
Rev.	Änderung	Datum	Name	Genehmigt	JTaubert



Hanse Yachts AG
Ladebower Chaussee 11
17493 Greifswald

DC Circuits
powerboard part 3

Hanse 460		H20B-7215-100-010 -03		Blatt: 14
				von 54 Bl.

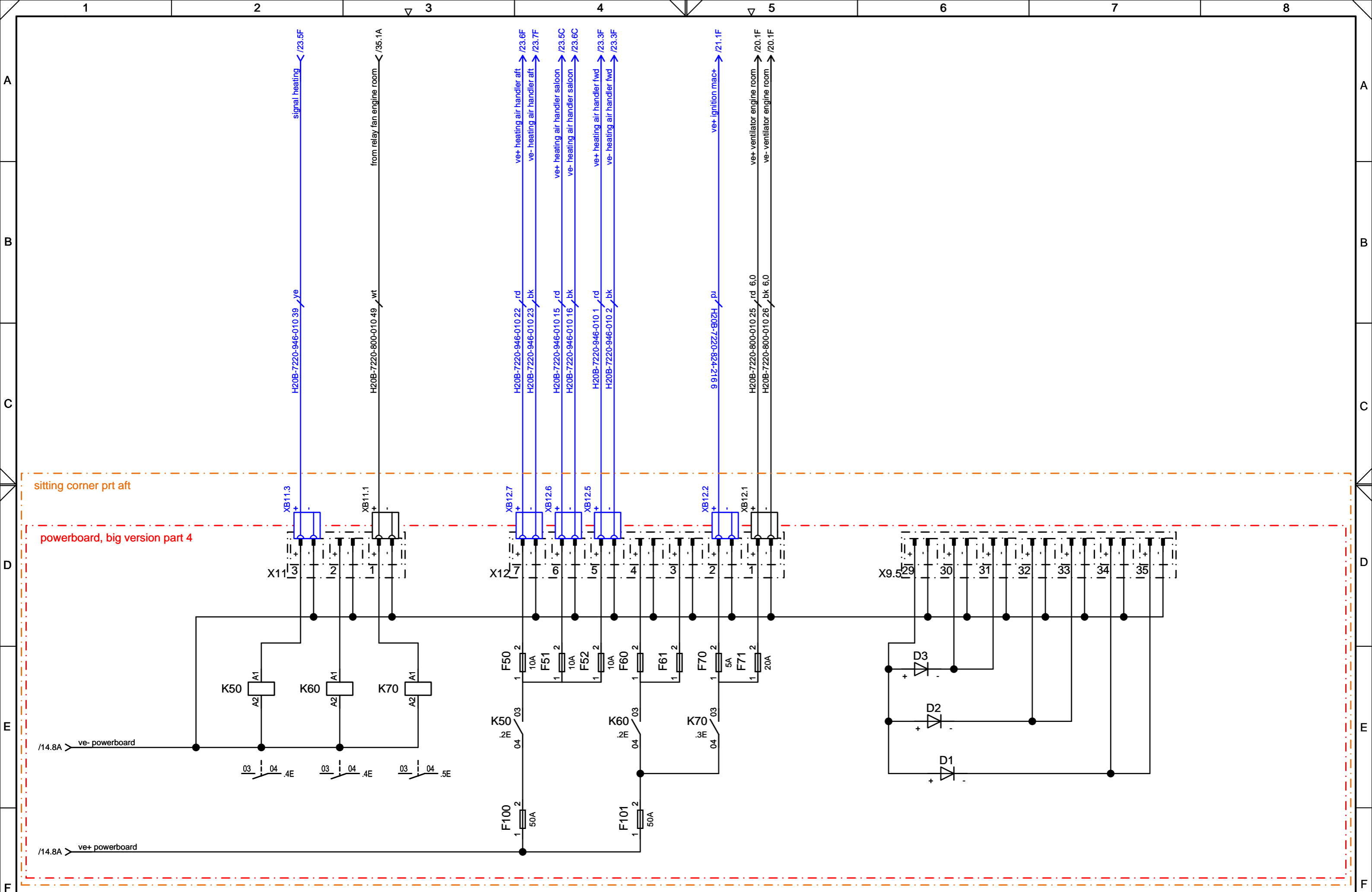

03	bp alarm added, watermaker updated	27.06.2022	DW	Datum	21.06.2021
02	changes solar panels; bathing platform	27.01.2022	JT	Gezeichnet	JTaubert
01	changes AC panel, battery protection, many changes	19.11.2021	JT	Geprüft	JTaubert
Rev.	Änderung	Datum	Name	Genehmigt	JTaubert



Hanse Yachts AG
Ladebower Chaussee 11
17493 Greifswald

DC Circuits
powerboard part 4

=		Blatt: 15
+		
Hanse 460	H20B-7215-100-010 -03	von 54 Bl.

DC Panel, Part 1
SIMARINE SPU 303

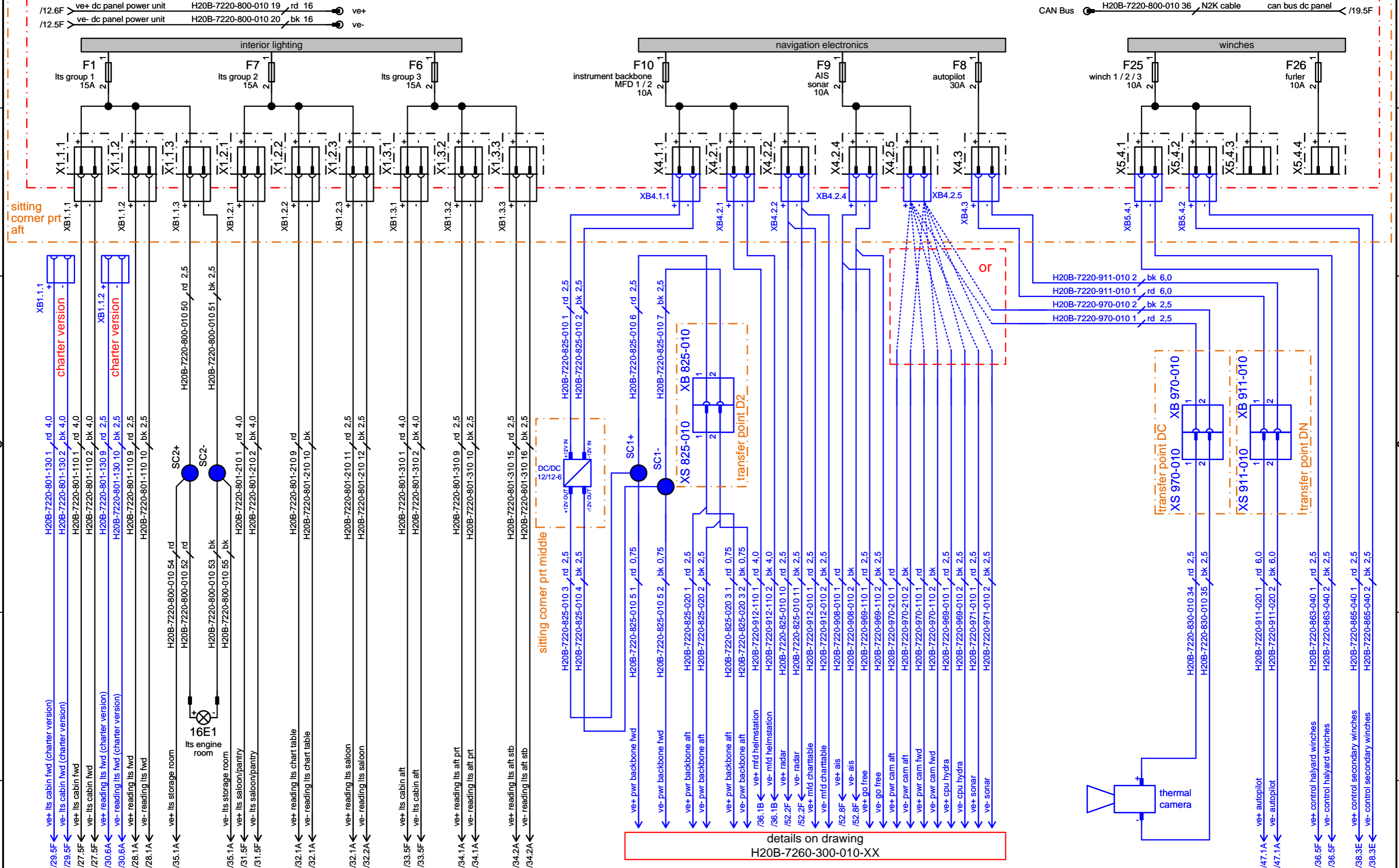

03	bp alarm added, watermaker updated	27.06.2022	DW	Datum	21.06.2021
02	changes solar panels; bathing platform	27.01.2022	JT	Gezeichnet	JTaubert
01	changes AC panel, battery protection, many changes	19.11.2021	JT	Geprüft	JTaubert
Rev.	Änderung	Datum	Name	Genehmigt	JTaubert



Hanse Yachts AG
Ladebower Chaussee 11
17493 Greifswald

DC Circuits
DC panel part 1

Hanse 460	H20B-7215-100-010 -03	Blatt: 16
		von 54 Bl.

DC Panel, Part 2
SIMARINE SPU 303

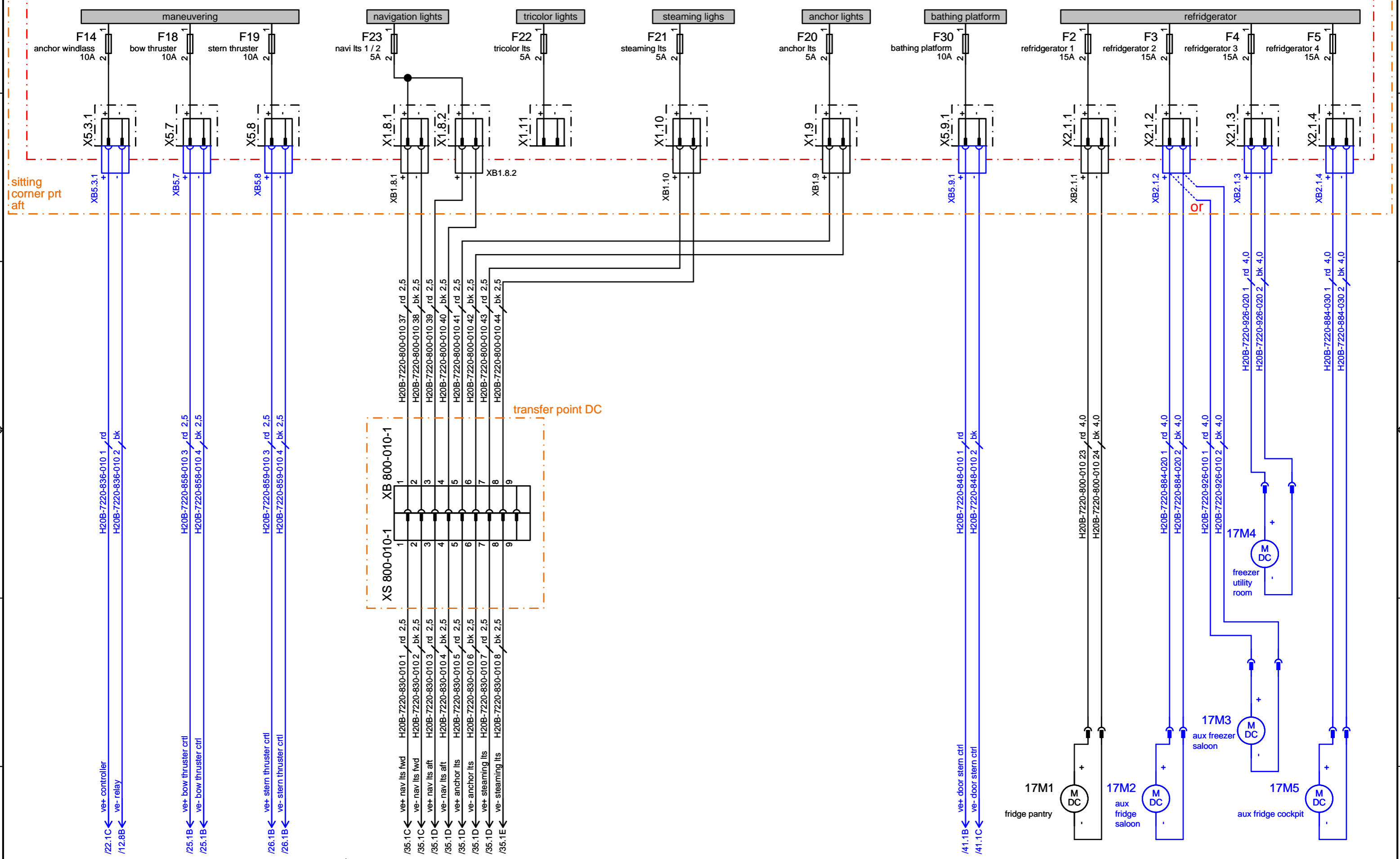

03	bp alarm added, watermaker updated	27.06.2022	DW	Datum	21.06.2021
02	changes solar panels; bathing platform	27.01.2022	JT	Gezeichnet	JTaubert
01	changes AC panel, battery protection, many changes	19.11.2021	JT	Geprüft	JTaubert
Rev.	Änderung	Datum	Name	Genehmigt	JTaubert



Hanse Yachts AG
Ladebower Chaussee 11
17493 Greifswald

DC Circuits
DC panel part 2

Hanse 460	H20B-7215-100-010 -03	Blatt: 17
		von 54 Bl.

DC Panel, Part 3
SIMARINE SPU 303

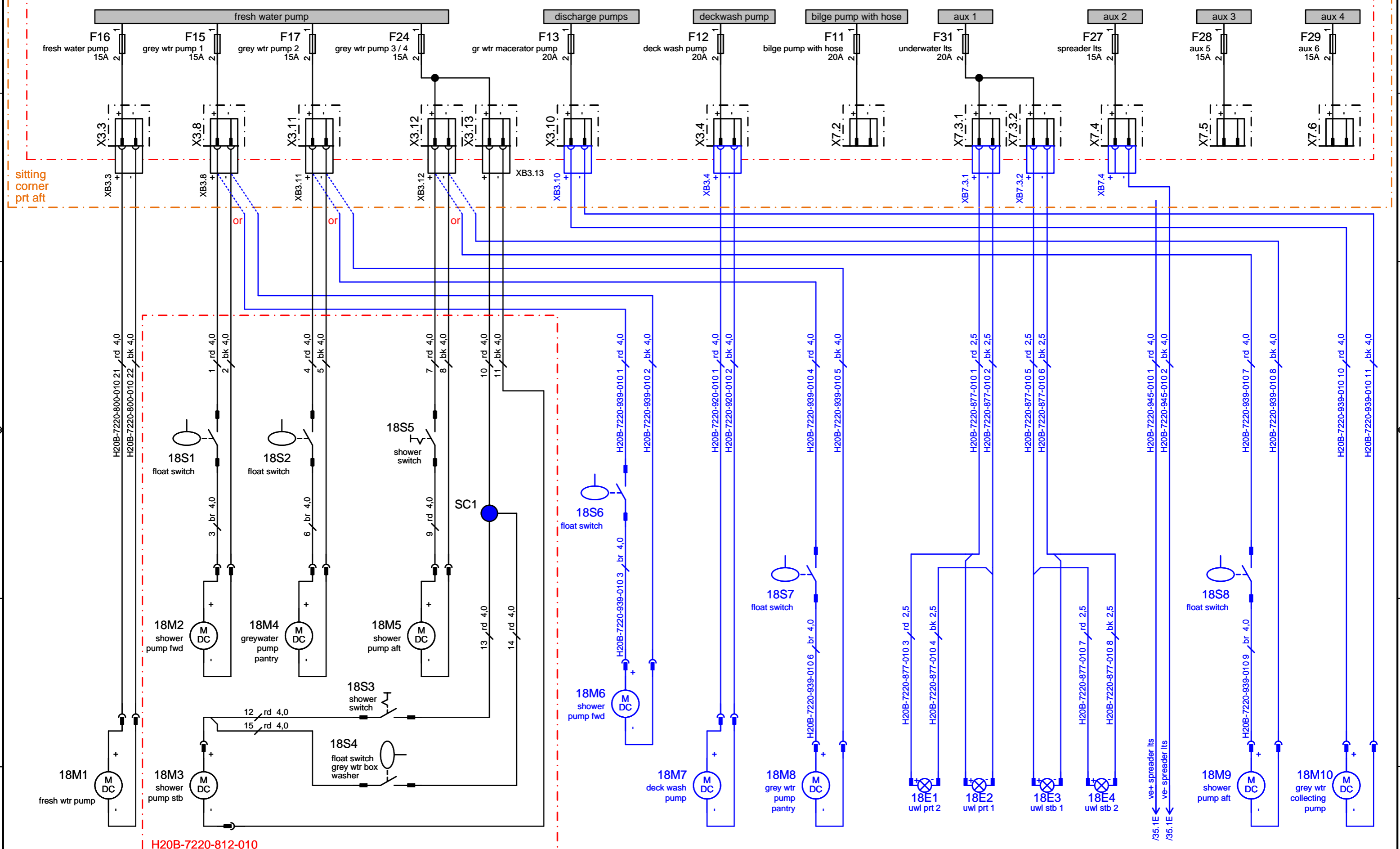

03	bp alarm added, watermaker updated	27.06.2022	DW	Datum	21.06.2021
02	changes solar panels; bathing platform	27.01.2022	JT	Gezeichnet	JTaubert
01	changes AC panel, battery protection, many changes	19.11.2021	JT	Geprüft	JTaubert
Rev.	Änderung	Datum	Name	Genehmigt	JTaubert



Hanse Yachts AG
Ladebower Chaussee 11
17493 Greifswald

DC Circuits
DC panel part 3

Hanse 460	H20B-7215-100-010 -03	Blatt: 18
		von 54 Bl.

DC Panel, Part 4
SIMARINE SCP
220 H

Information Display

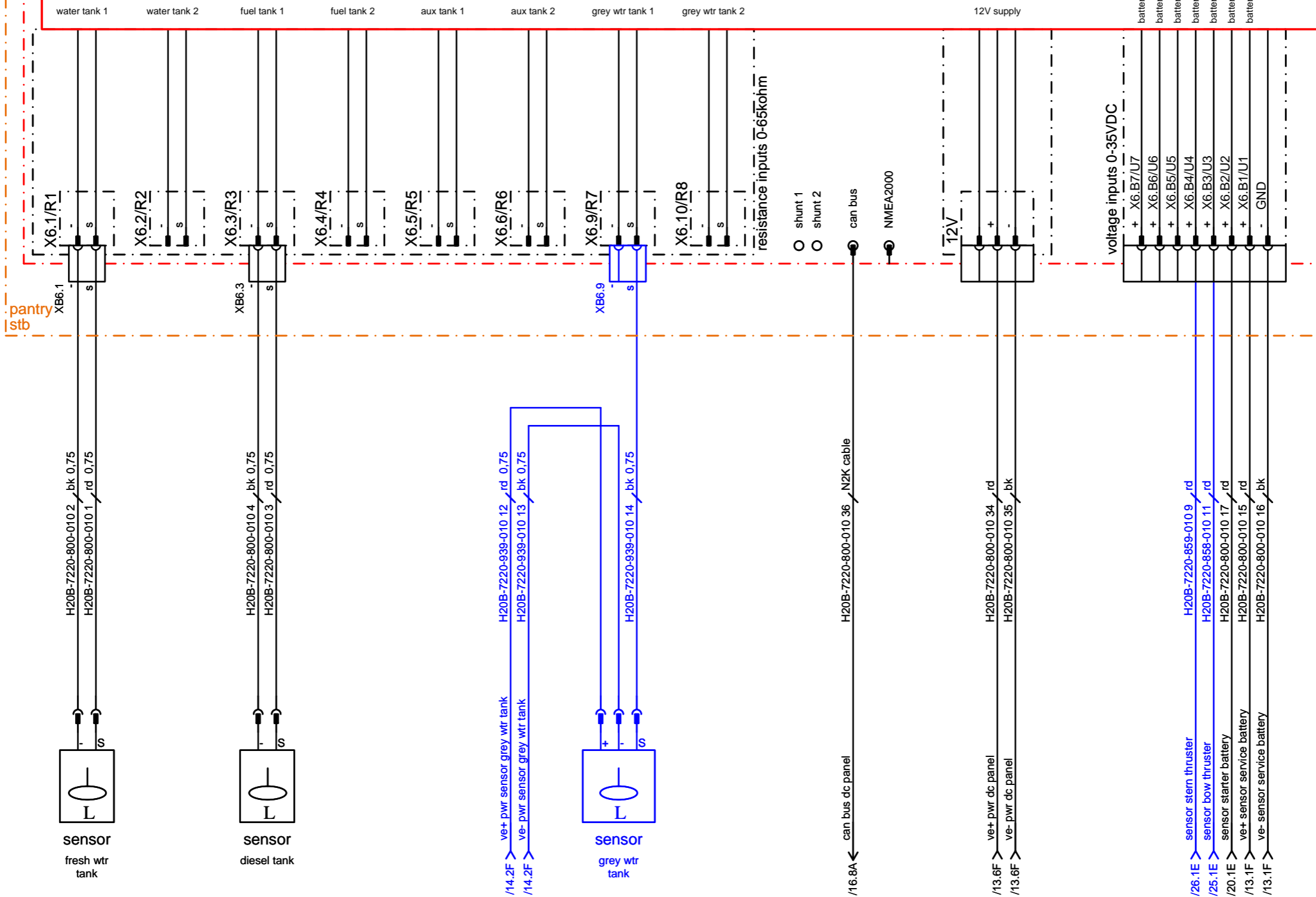

03	bp alarm added, watermaker updated	27.06.2022	DW	Datum	21.06.2021
02	changes solar panels; bathing platform	27.01.2022	JT	Gezeichnet	JTaubert
01	changes AC panel, battery protection, many changes	19.11.2021	JT	Geprüft	JTaubert
Rev.	Änderung	Datum	Name	Genehmigt	JTaubert



Hanse Yachts AG
Ladebower Chaussee 11
17493 Greifswald

DC Circuits
DC panel part 4

Hanse 460		H20B-7215-100-010 -03		Blatt: 19
				von 54 Bl.

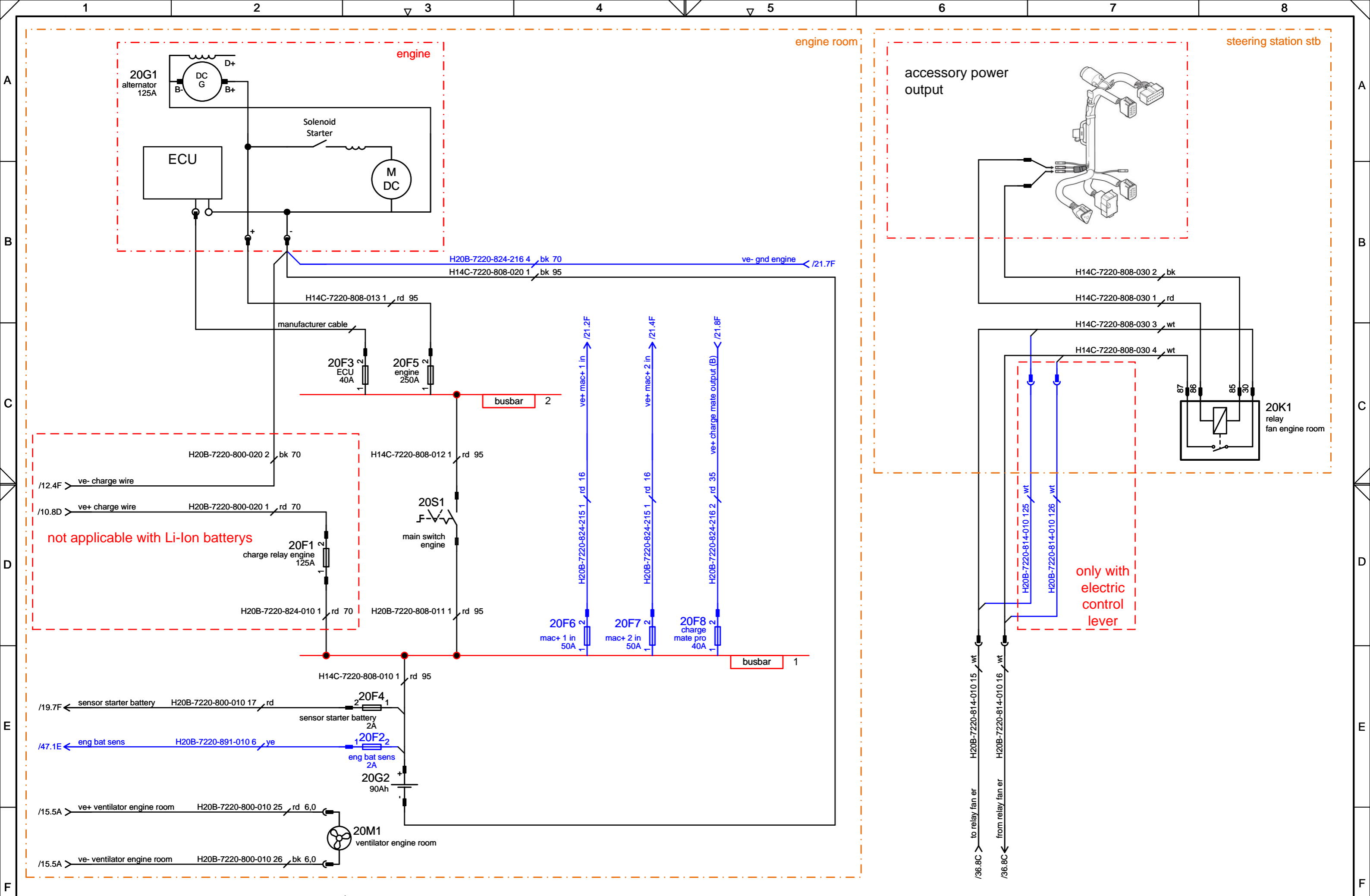

03	bp alarm added, watermaker updated	27.06.2022	DW	Datum	21.06.2021
02	changes solar panels; bathing platform	27.01.2022	JT	Gezeichnet	JTaubert
01	changes AC panel, battery protection, many changes	19.11.2021	JT	Geprüft	JTaubert
Rev.	Änderung	Datum	Name	Genehmigt	JTaubert



 Hanse Yachts AG
 Ladebower Chaussee 11
 17493 Greifswald

DC Circuits engine

Hanse 460		H20B-7215-100-010 -03	Blatt: 20
			von 54 Bl.

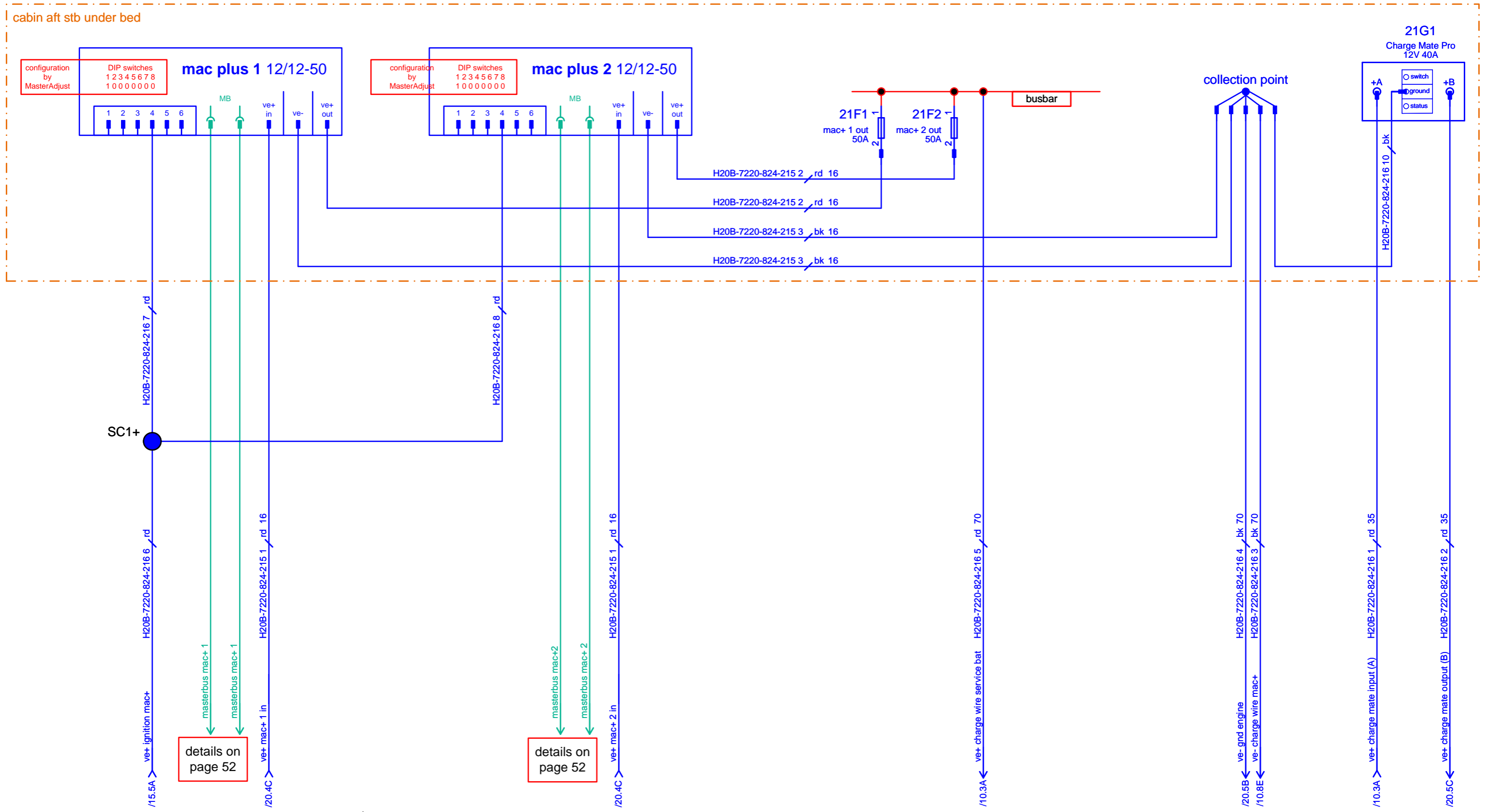

03	bp alarm added, watermaker updated	27.06.2022	DW	Datum	21.06.2021
02	changes solar panels; bathing platform	27.01.2022	JT	Gezeichnet	JTaubert
01	changes AC panel, battery protection, many changes	19.11.2021	JT	Geprüft	JTaubert
Rev.	Änderung	Datum	Name	Genehmigt	JTaubert



Hanse Yachts AG
Ladebower Chaussee 11
17493 Greifswald

DC Circuits
Mac+, charge mate pro

Hanse 460		H20B-7215-100-010 -03		Blatt: 21
				von 54 Bl.

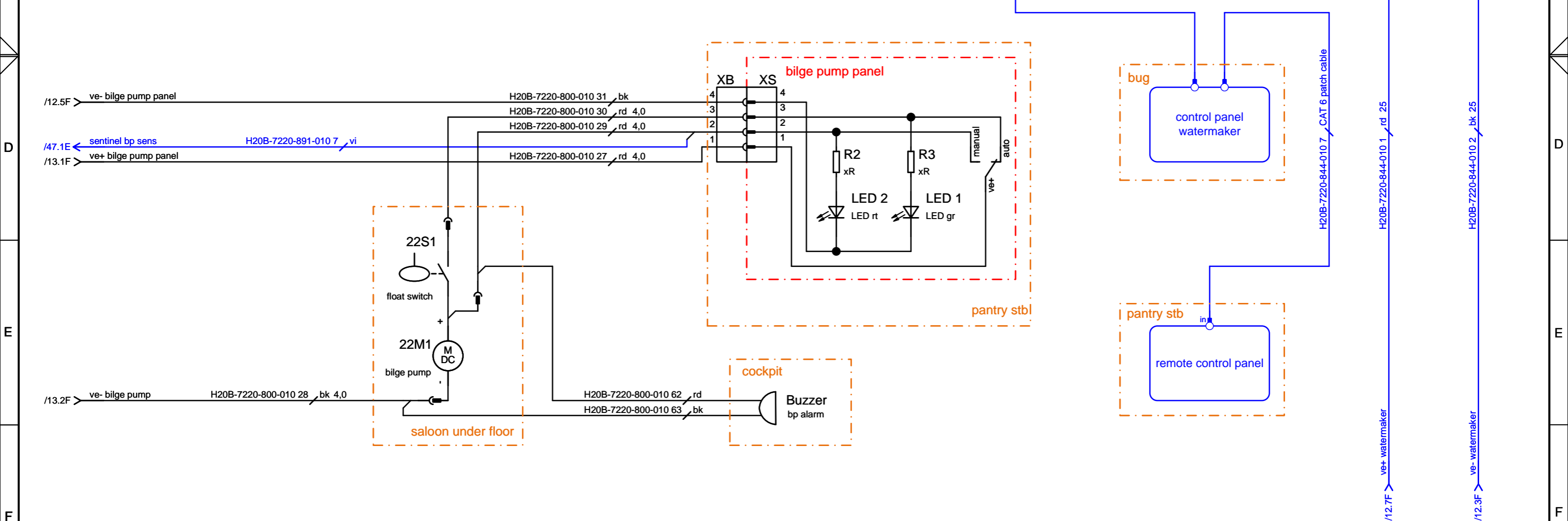
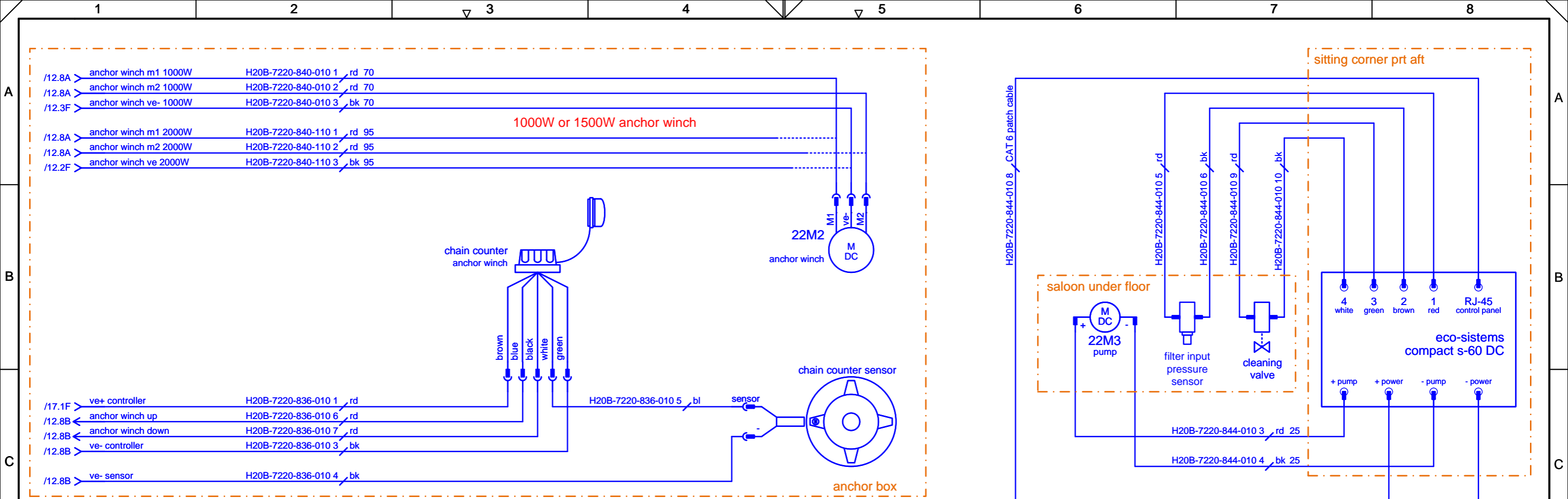

03	bp alarm added, watermaker updated	27.06.2022	DW	Datum	21.06.2021	 Hanse Yachts AG Ladebower Chaussee 11 17493 Greifswald	DC Circuits anchor winch, bilge pump panel, watermaker	Hanse 460	H20B-7215-100-010 -03	Blatt: 22 von 54 Bl.
02	changes solar panels; bathing platform	27.01.2022	JT	Gezeichnet	JTaubert					
01	changes AC panel, battery protection, many changes	19.11.2021	JT	Geprüft	JTaubert					
Rev.	Änderung	Datum	Name	Genehmigt	JTaubert					

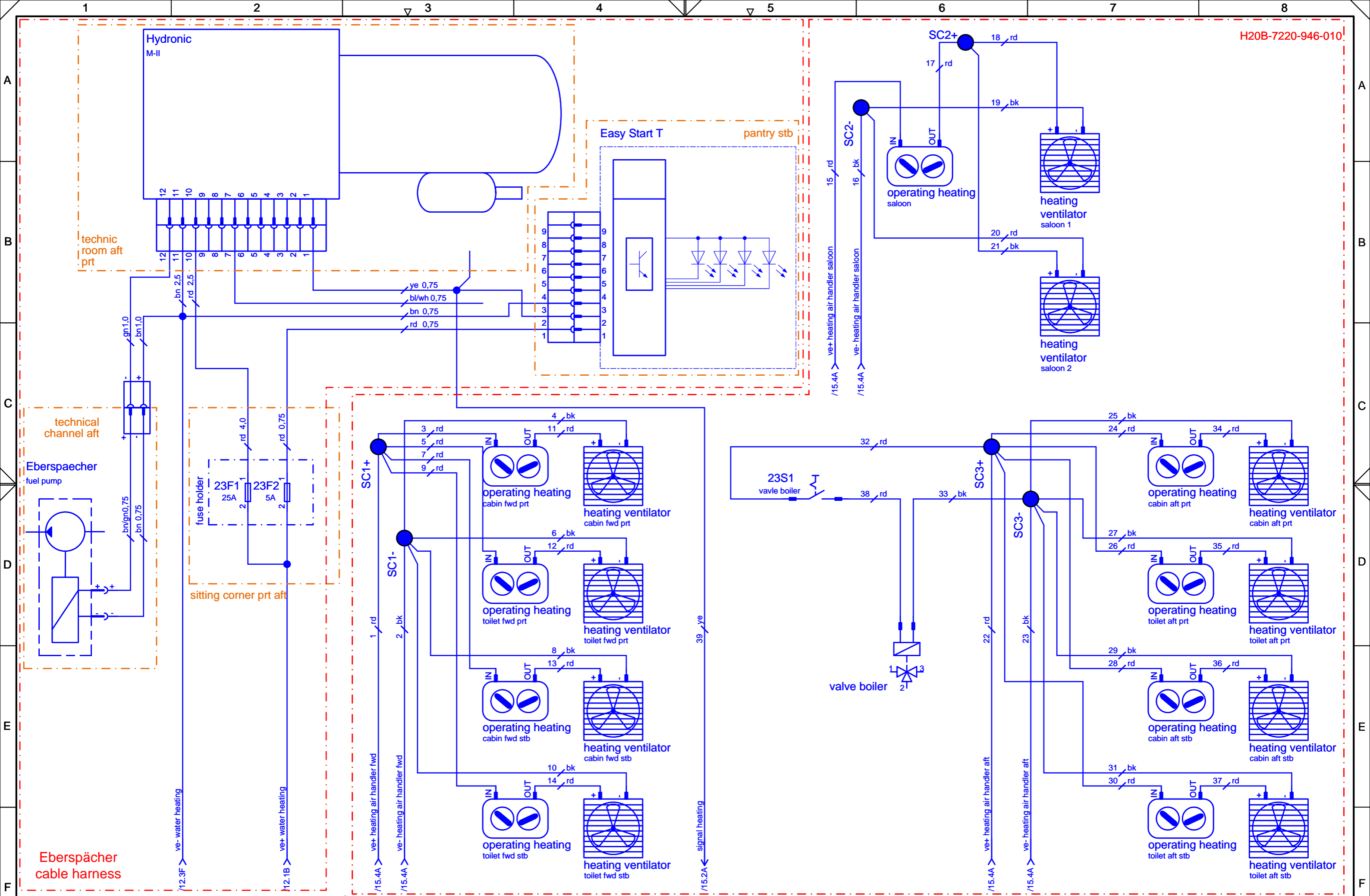

H20B-7220-946-010

03	bp alarm added, watermaker updated	27.06.2022	DW	Datum	21.06.2021
02	changes solar panels; bathing platform	27.01.2022	JT	Gezeichnet	JTaubert
01	changes AC panel, battery protection, many changes	19.11.2021	JT	Geprüft	JTaubert
Rev.	Änderung	Datum	Name	Genehmigt	JTaubert



Hanse Yachts AG
Ladebower Chaussee 11
17493 Greifswald

DC Circuits
water heating

Hanse 460		H20B-7215-100-010 -03		Blatt: 23
				von 54 Bl.

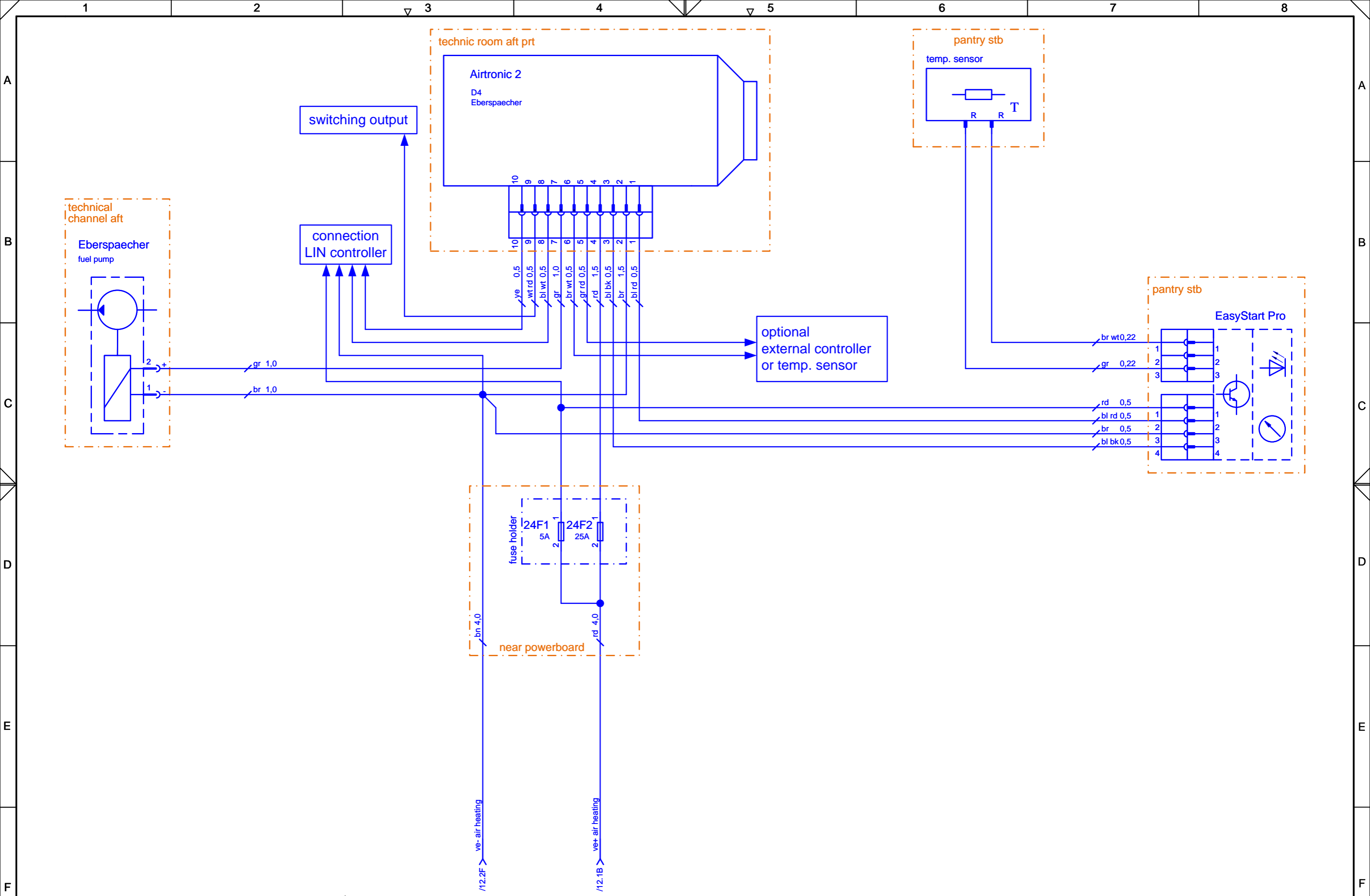

03	bp alarm added, watermaker updated	27.06.2022	DW	Datum	21.06.2021
02	changes solar panels; bathing platform	27.01.2022	JT	Gezeichnet	JTaubert
01	changes AC panel, battery protection, many changes	19.11.2021	JT	Geprüft	JTaubert
Rev.	Änderung	Datum	Name	Genehmigt	JTaubert



Hanse Yachts AG
Ladebower Chaussee 11
17493 Greifswald

DC Circuits
air heating

=			
+			
Hanse 460	H20B-7215-100-010 -03	Blatt:	24
		von 54	Bl.

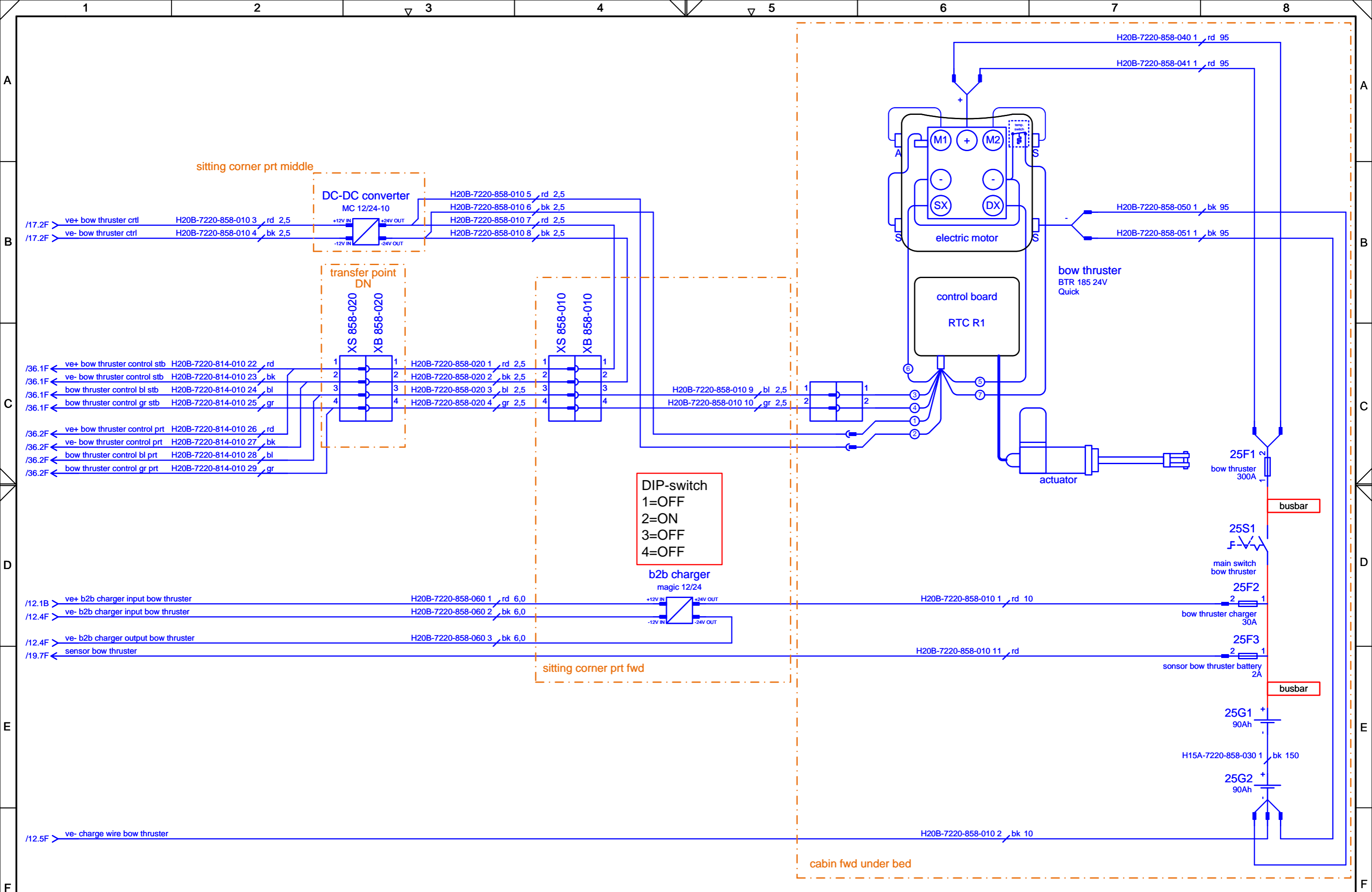

DIP-switch
 1=OFF
 2=ON
 3=OFF
 4=OFF

03	bp alarm added, watermaker updated	27.06.2022	DW	Datum	21.06.2021
02	changes solar panels; bathing platform	27.01.2022	JT	Gezeichnet	JTaubert
01	changes AC panel, battery protection, many changes	19.11.2021	JT	Geprüft	JTaubert
Rev.	Änderung	Datum	Name	Genehmigt	JTaubert



Hanse Yachts AG
 Ladebower Chaussee 11
 17493 Greifswald

DC Circuits
 bow thruster

Hanse 460		H20B-7215-100-010 -03		Blatt: 25
				von 54 Bl.

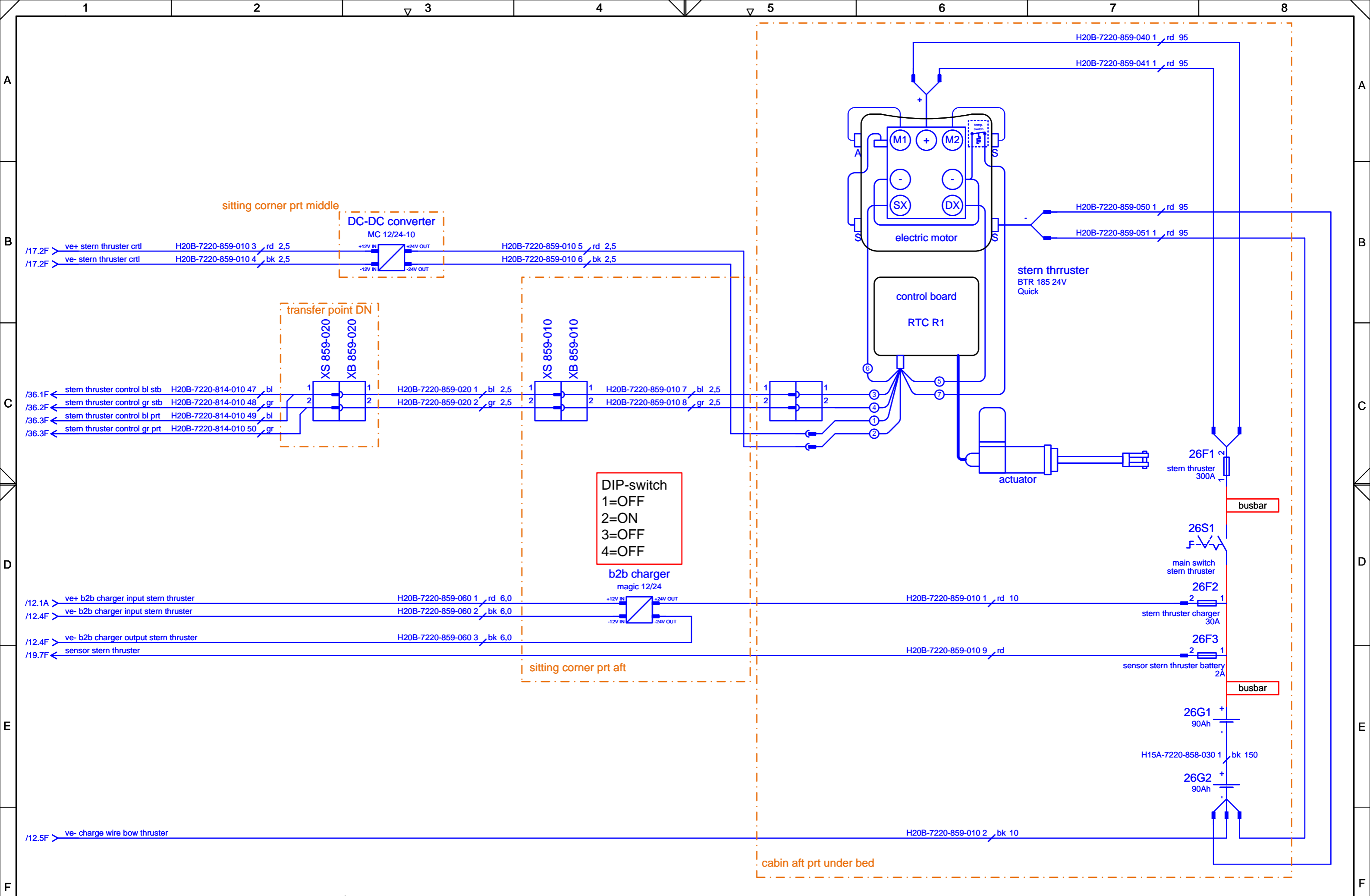

03	bp alarm added, watermaker updated	27.06.2022	DW	Datum	21.06.2021
02	changes solar panels; bathing platform	27.01.2022	JT	Gezeichnet	JTaubert
01	changes AC panel, battery protection, many changes	19.11.2021	JT	Geprüft	JTaubert
Rev.	Änderung	Datum	Name	Genehmigt	JTaubert



Hanse Yachts AG
Ladebower Chaussee 11
17493 Greifswald

DC Circuits
stern thruster

Hanse 460		H20B-7215-100-010 -03		Blatt: 26
				von 54 Bl.

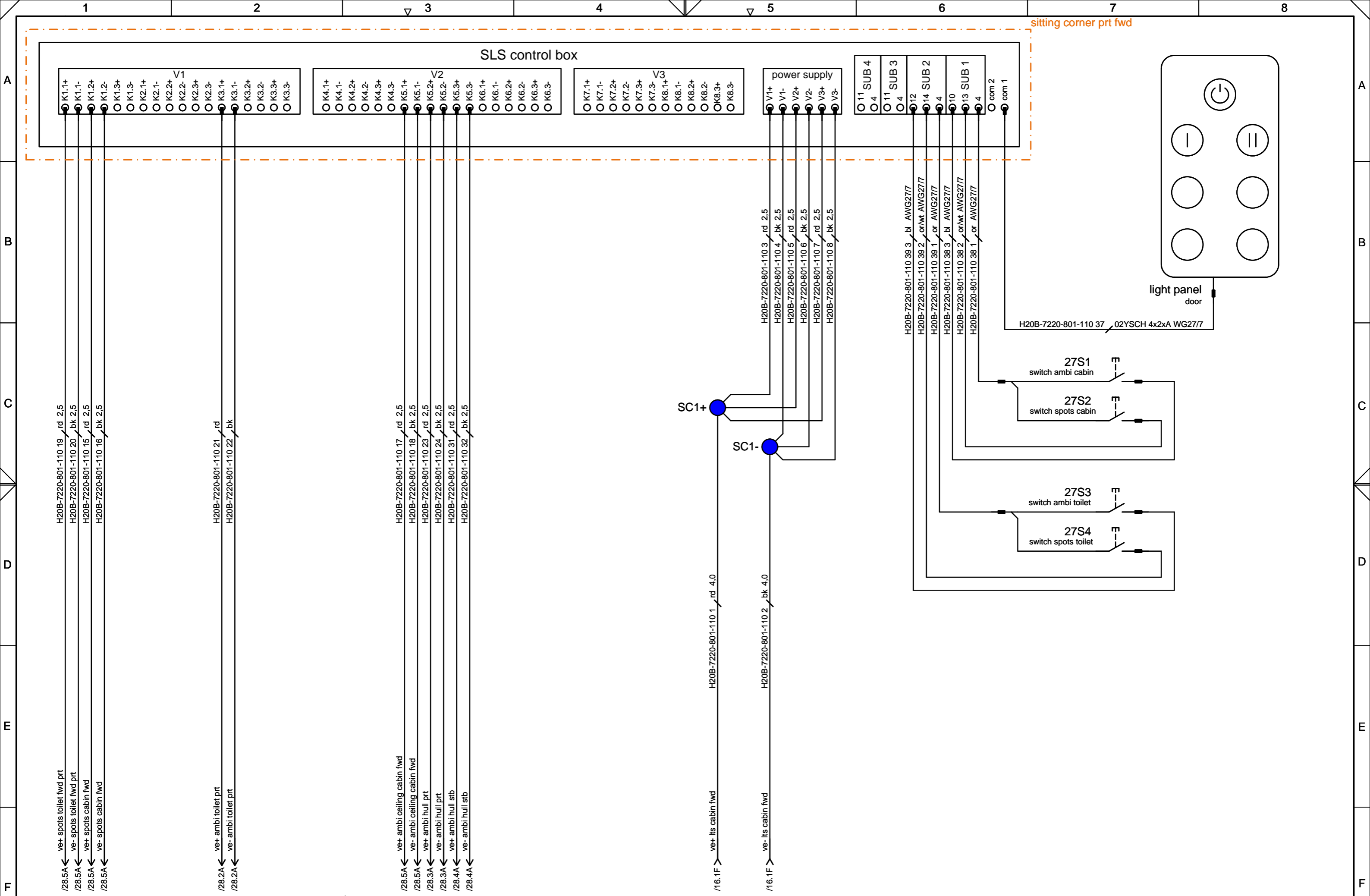

03	bp alarm added, watermaker updated	27.06.2022	DW	Datum	21.06.2021
02	changes solar panels; bathing platform	27.01.2022	JT	Gezeichnet	JTaubert
01	changes AC panel, battery protection, many changes	19.11.2021	JT	Geprüft	JTaubert
Rev.	Änderung	Datum	Name	Genehmigt	JTaubert



Hanse Yachts AG
Ladebower Chaussee 11
17493 Greifswald

DC Circuits
light control owner cabin

Hanse 460		H20B-7215-100-010 -03		Blatt: 27
				von 54 Bl.

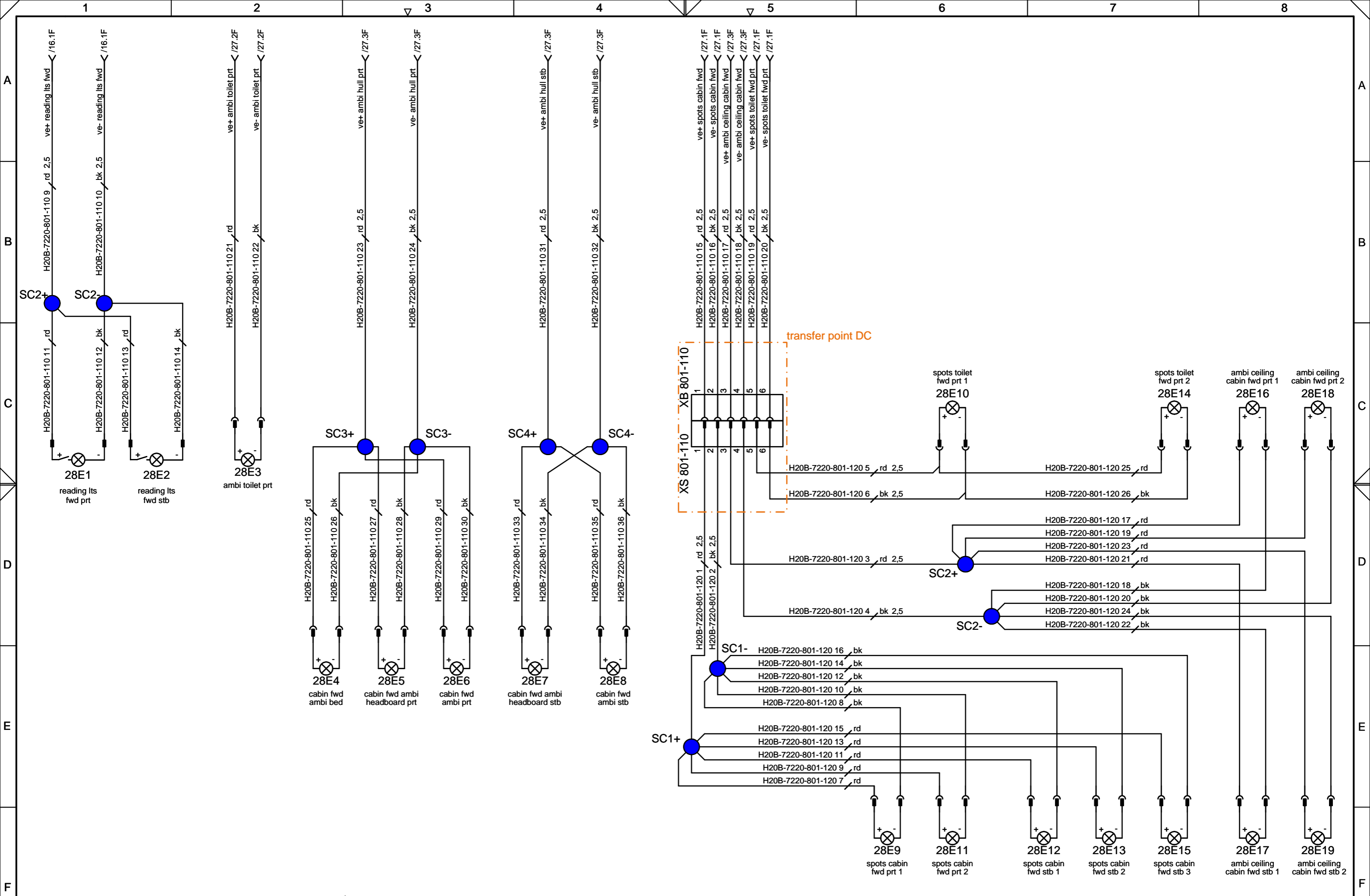

03	bp alarm added, watermaker updated	27.06.2022	DW	Datum	21.06.2021
02	changes solar panels; bathing platform	27.01.2022	JT	Gezeichnet	JTaubert
01	changes AC panel, battery protection, many changes	19.11.2021	JT	Geprüft	JTaubert
Rev.	Änderung	Datum	Name	Genehmigt	JTaubert



Hanse Yachts AG
Ladebower Chaussee 11
17493 Greifswald

DC Circuits
lights owner cabin

Hanse 460		H20B-7215-100-010 -03		Blatt: 28
				von 54 Bl.

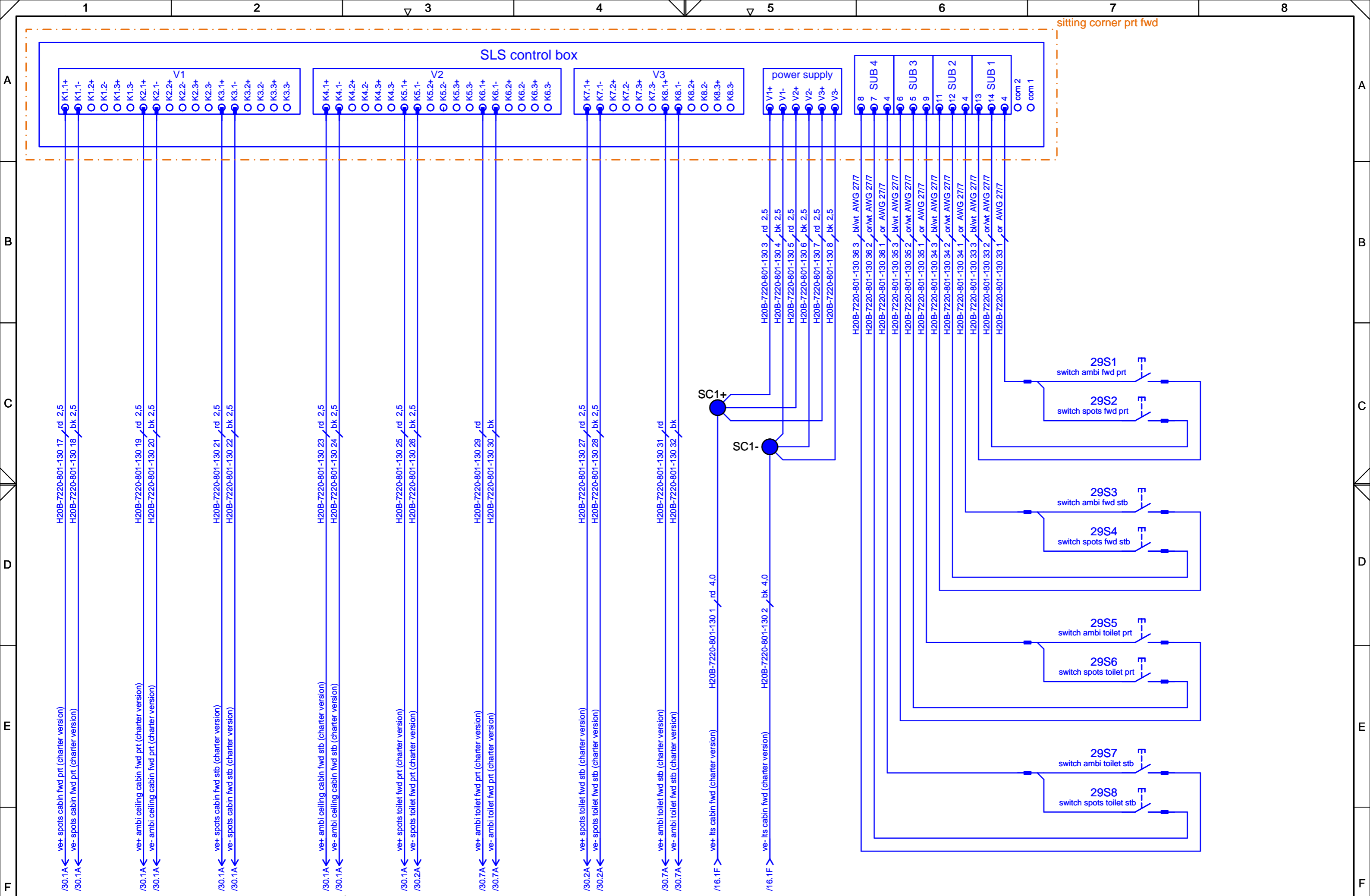

03	bp alarm added, watermaker updated	27.06.2022	DW	Datum	21.06.2021
02	changes solar panels; bathing platform	27.01.2022	JT	Gezeichnet	JTaubert
01	changes AC panel, battery protection, many changes	19.11.2021	JT	Geprüft	JTaubert
Rev.	Änderung	Datum	Name	Genehmigt	JTaubert



Hanse Yachts AG
Ladebower Chaussee 11
17493 Greifswald

DC Circuits
light control charter version

Hanse 460		H20B-7215-100-010 -03		Blatt: 29
				von 54 Bl.

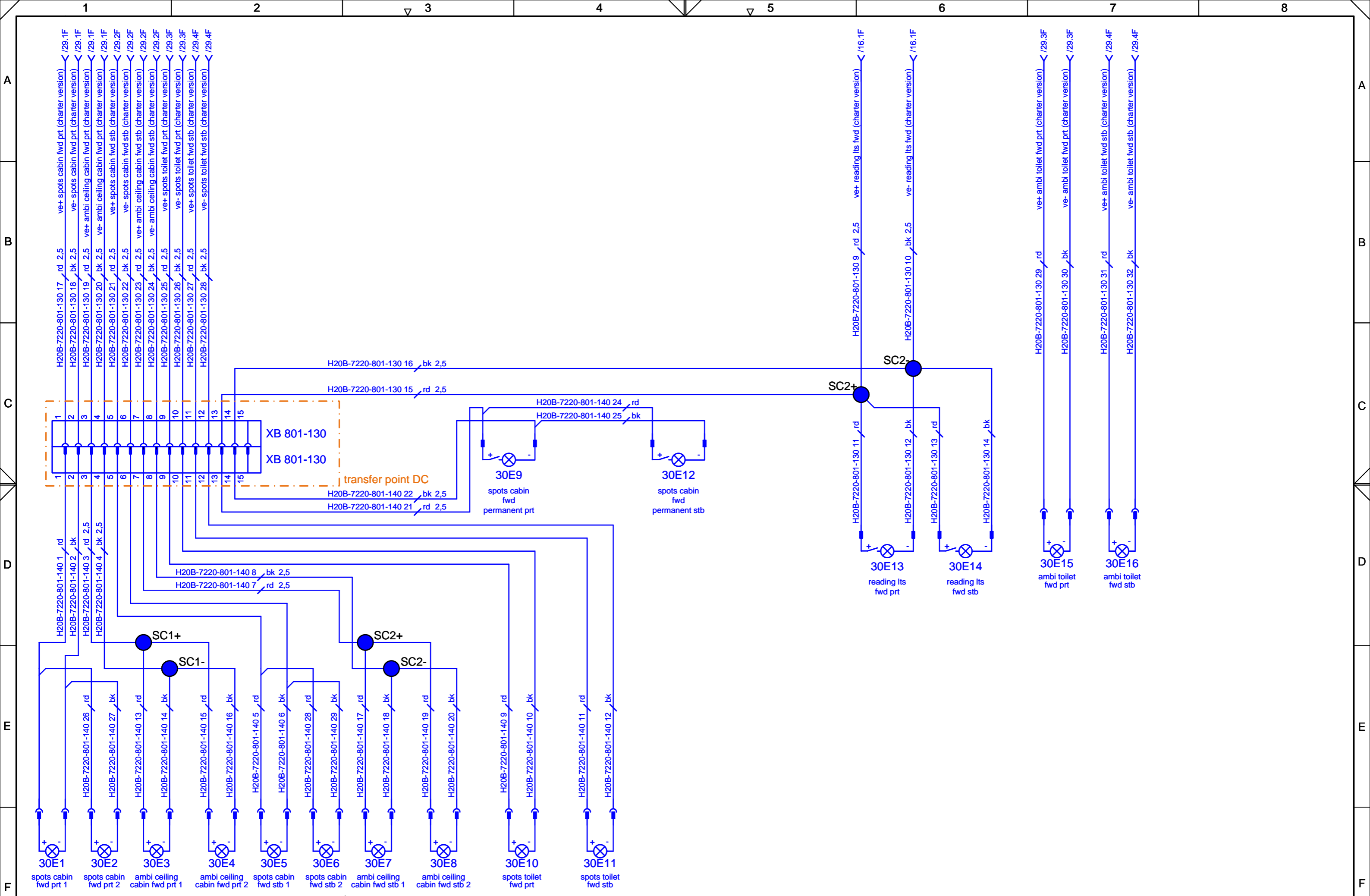

03	bp alarm added, watermaker updated	27.06.2022	DW	Datum	21.06.2021
02	changes solar panels; bathing platform	27.01.2022	JT	Gezeichnet	JTaubert
01	changes AC panel, battery protection, many changes	19.11.2021	JT	Geprüft	JTaubert
Rev.	Änderung	Datum	Name	Genehmigt	JTaubert



Hanse Yachts AG
Ladebower Chaussee 11
17493 Greifswald

DC Circuits
lights charter version

=			
+			
Hanse 460		H20B-7215-100-010 -03	
		Blatt: 30	
		von 54 Bl.	

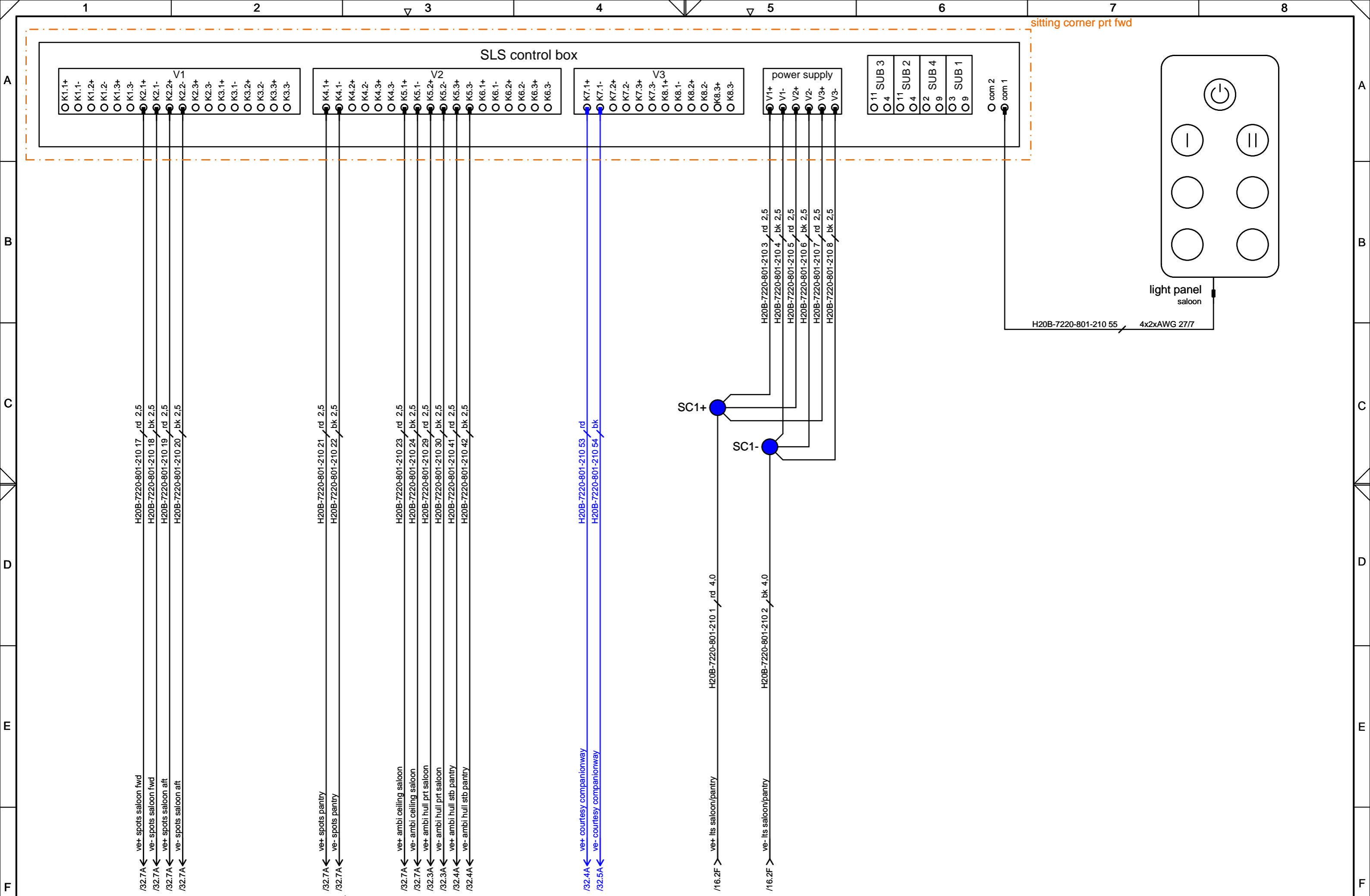

03	bp alarm added, watermaker updated	27.06.2022	DW	Datum	21.06.2021
02	changes solar panels; bathing platform	27.01.2022	JT	Gezeichnet	JTaubert
01	changes AC panel, battery protection, many changes	19.11.2021	JT	Geprüft	JTaubert
Rev.	Änderung	Datum	Name	Genehmigt	JTaubert



Hanse Yachts AG
Ladebower Chaussee 11
17493 Greifswald

DC Circuits
light control saloon/pantry

Hanse 460		H20B-7215-100-010 -03		Blatt: 31
				von 54 Bl.

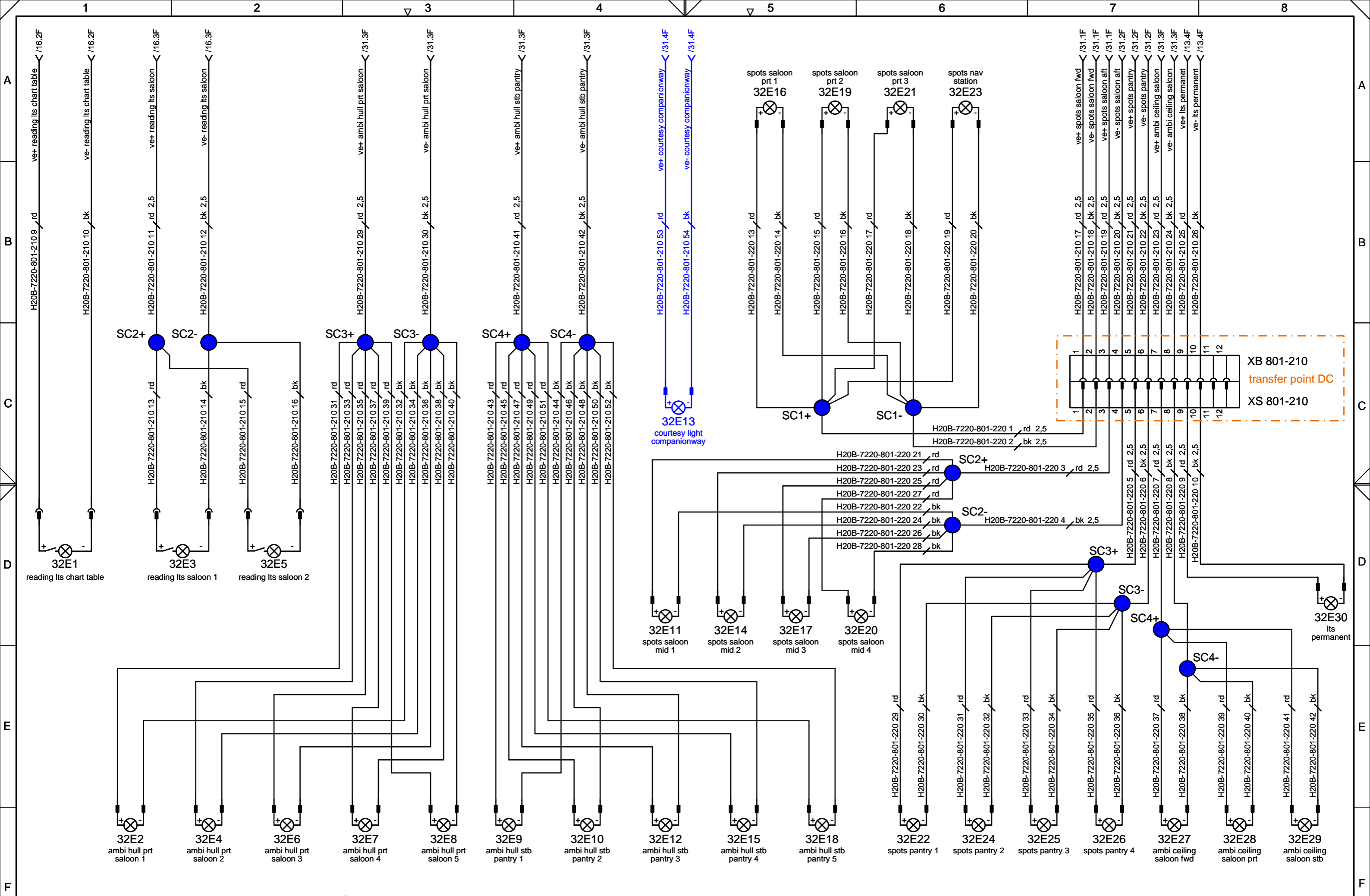

03	bp alarm added, watermaker updated	27.06.2022	DW	Datum	21.06.2021
02	changes solar panels; bathing platform	27.01.2022	JT	Gezeichnet	JTaubert
01	changes AC panel, battery protection, many changes	19.11.2021	JT	Geprüft	JTaubert
Rev.	Änderung	Datum	Name	Genehmigt	JTaubert



Hanse Yachts AG
Ladeborwer Chaussee 11
17493 Greifswald

DC Circuits
lights saloon/pantry

Hanse 460		H20B-7215-100-010 -03		Blatt: 32
				von 54 Bl.

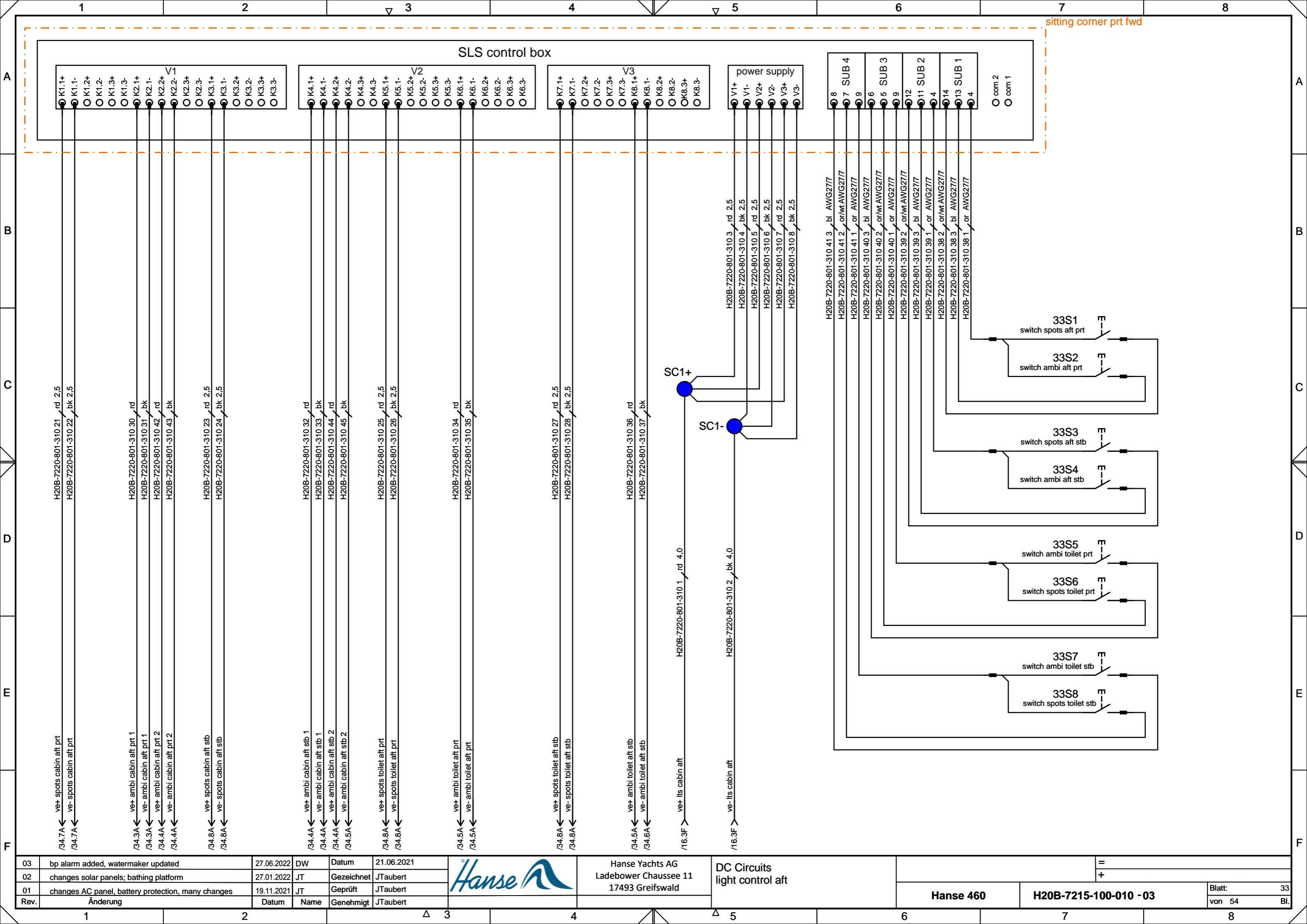

03	bp alarm added, watermaker updated	27.06.2022	DW	Datum	21.06.2021
02	changes solar panels; bathing platform	27.01.2022	JT	Gezeichnet	JTaubert
01	changes AC panel, battery protection, many changes	19.11.2021	JT	Geprüft	JTaubert
Rev.	Änderung	Datum	Name	Genehmigt	JTaubert



Hanse Yachts AG
Ladebower Chaussee 11
17493 Greifswald

DC Circuits
light control aft

Hanse 460		H20B-7215-100-010 -03		Blatt: 33
				von 54 Bl.

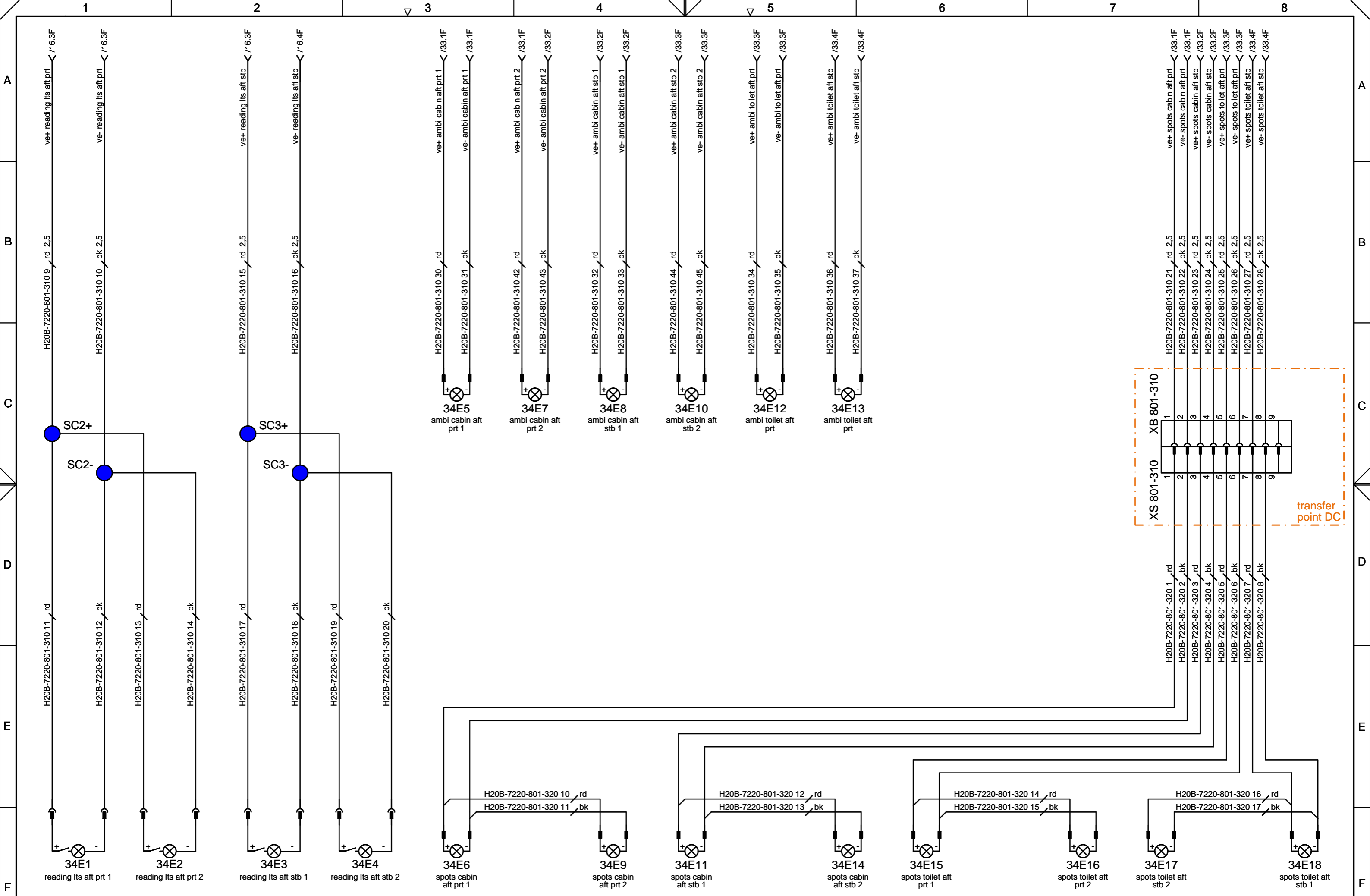



03	bp alarm added, watermaker updated	27.06.2022	DW	Datum	21.06.2021
02	changes solar panels; bathing platform	27.01.2022	JT	Gezeichnet	JTaubert
01	changes AC panel, battery protection, many changes	19.11.2021	JT	Geprüft	JTaubert
Rev.	Änderung	Datum	Name	Genehmigt	JTaubert

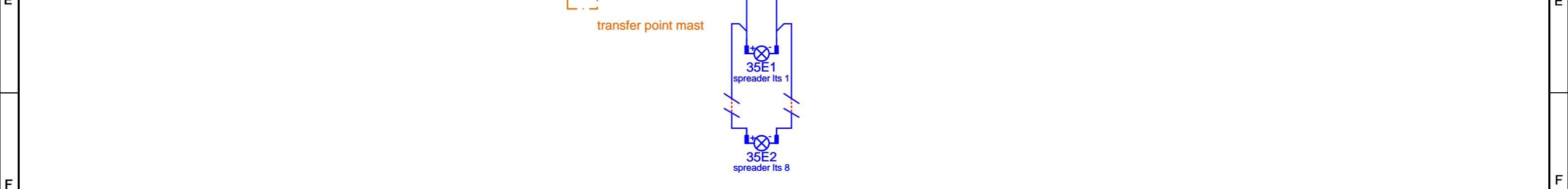
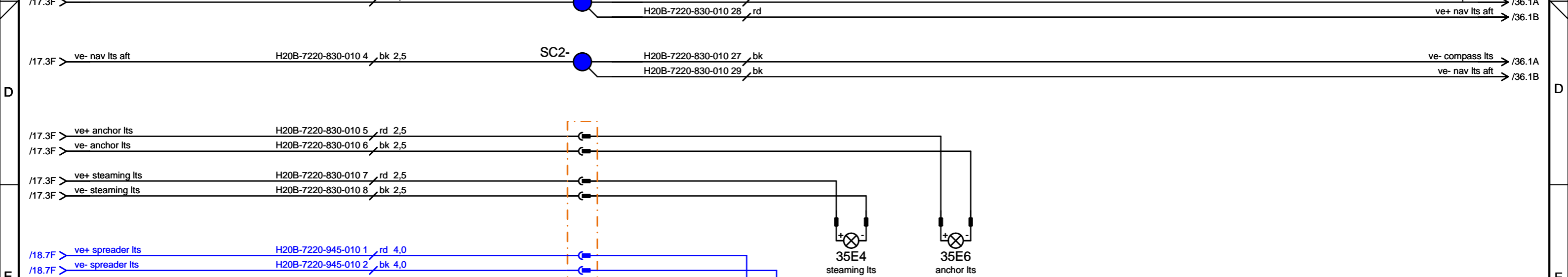
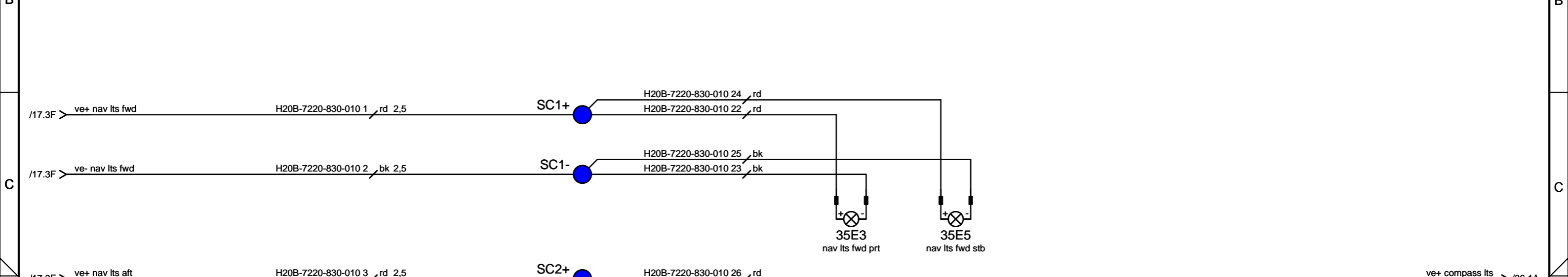
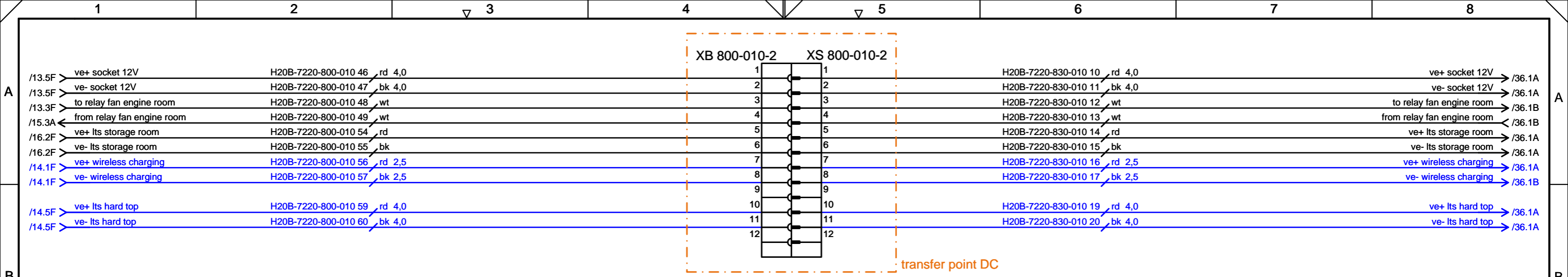

Hanse Yachts AG
 Ladebower Chaussee 11
 17493 Greifswald

DC Circuits
lights aft

Hanse 460		H20B-7215-100-010 -03		Blatt: 34
				von 54 Bl.

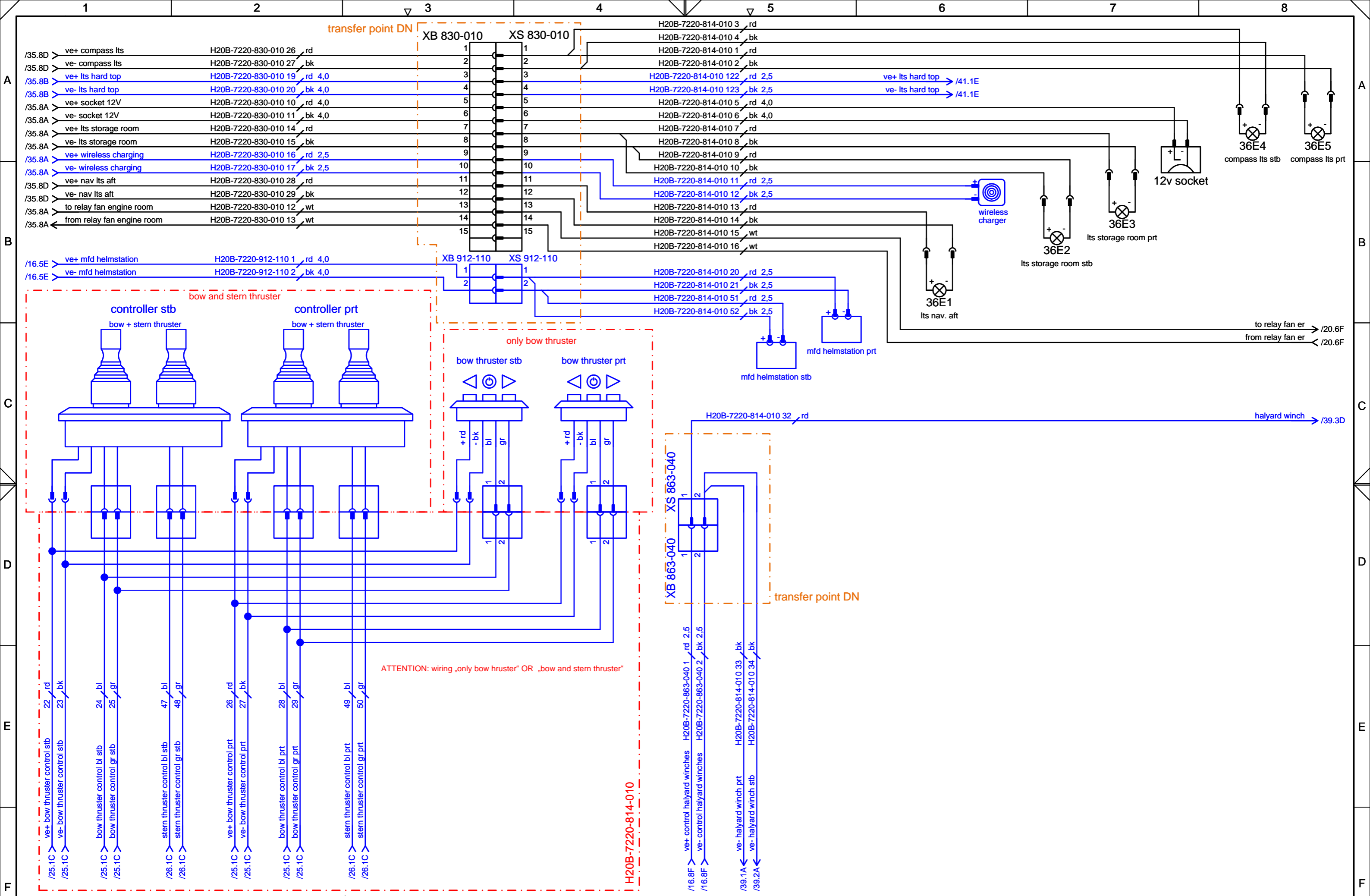

03	bp alarm added, watermaker updated	27.06.2022	DW	Datum	21.06.2021	 Hanse Yachts AG Ladebower Chaussee 11 17493 Greifswald	DC Circuits nav. Its, steaming Its, anchor Its, transfer point	= +	Blatt: 35 von 54 Bl.
02	changes solar panels; bathing platform	27.01.2022	JT	Gezeichnet	JTaubert				
01	changes AC panel, battery protection, many changes	19.11.2021	JT	Geprüft	JTaubert				
Rev.	Änderung	Datum	Name	Genehmigt	JTaubert				



03	bp alarm added, watermaker updated	27.06.2022	DW	Datum	21.06.2021
02	changes solar panels; bathing platform	27.01.2022	JT	Gezeichnet	JTaubert
01	changes AC panel, battery protection, many changes	19.11.2021	JT	Geprüft	JTaubert
Rev.	Änderung	Datum	Name	Genehmigt	JTaubert

Hanse Yachts AG
Ladebower Chaussee 11
17493 Greifswald

DC Circuits
dashboard, transfer point

Hanse 460	H20B-7215-100-010 -03	Blatt: 36 von 54 Bl.
------------------	------------------------------	-------------------------

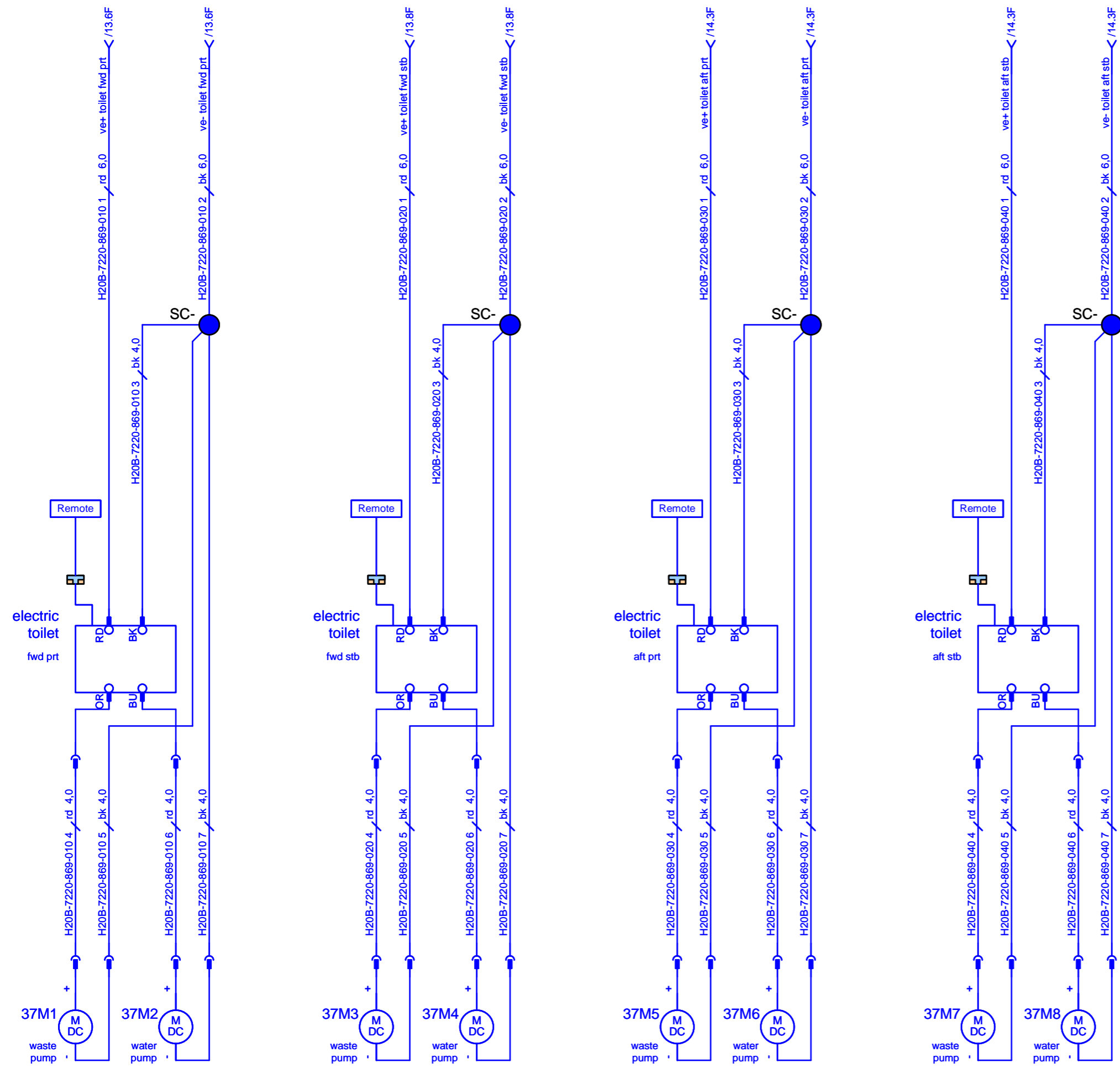

03	bp alarm added, watermaker updated	27.06.2022	DW	Datum	21.06.2021
02	changes solar panels; bathing platform	27.01.2022	JT	Gezeichnet	JTaubert
01	changes AC panel, battery protection, many changes	19.11.2021	JT	Geprüft	JTaubert
Rev.	Änderung	Datum	Name	Genehmigt	JTaubert



Hanse Yachts AG
Ladebower Chaussee 11
17493 Greifswald

DC Circuits
electric toilets

=			
+			
Hanse 460		H20B-7215-100-010 -03	
		Blatt: 37	
		von 54 Bl.	

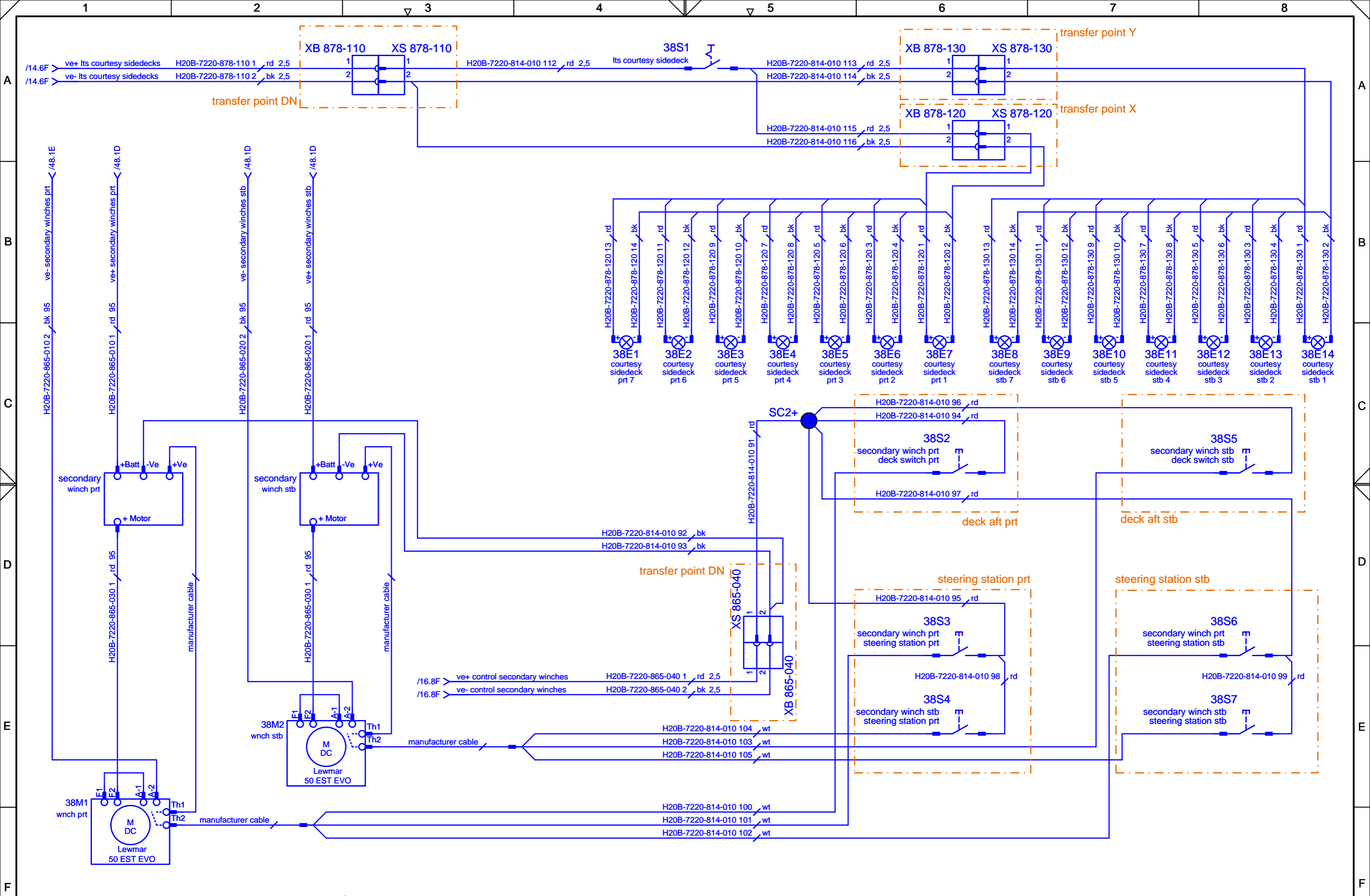

03	bp alarm added, watermaker updated	27.06.2022	DW	Datum	21.06.2021
02	changes solar panels; bathing platform	27.01.2022	JT	Gezeichnet	JTaubert
01	changes AC panel, battery protection, many changes	19.11.2021	JT	Geprüft	JTaubert
Rev.	Änderung	Datum	Name	Genehmigt	JTaubert

Hanse Yachts AG
 Salinenstr. 22
 17489 Greifswald

DC Circuits
secondary winches, courtesy lts

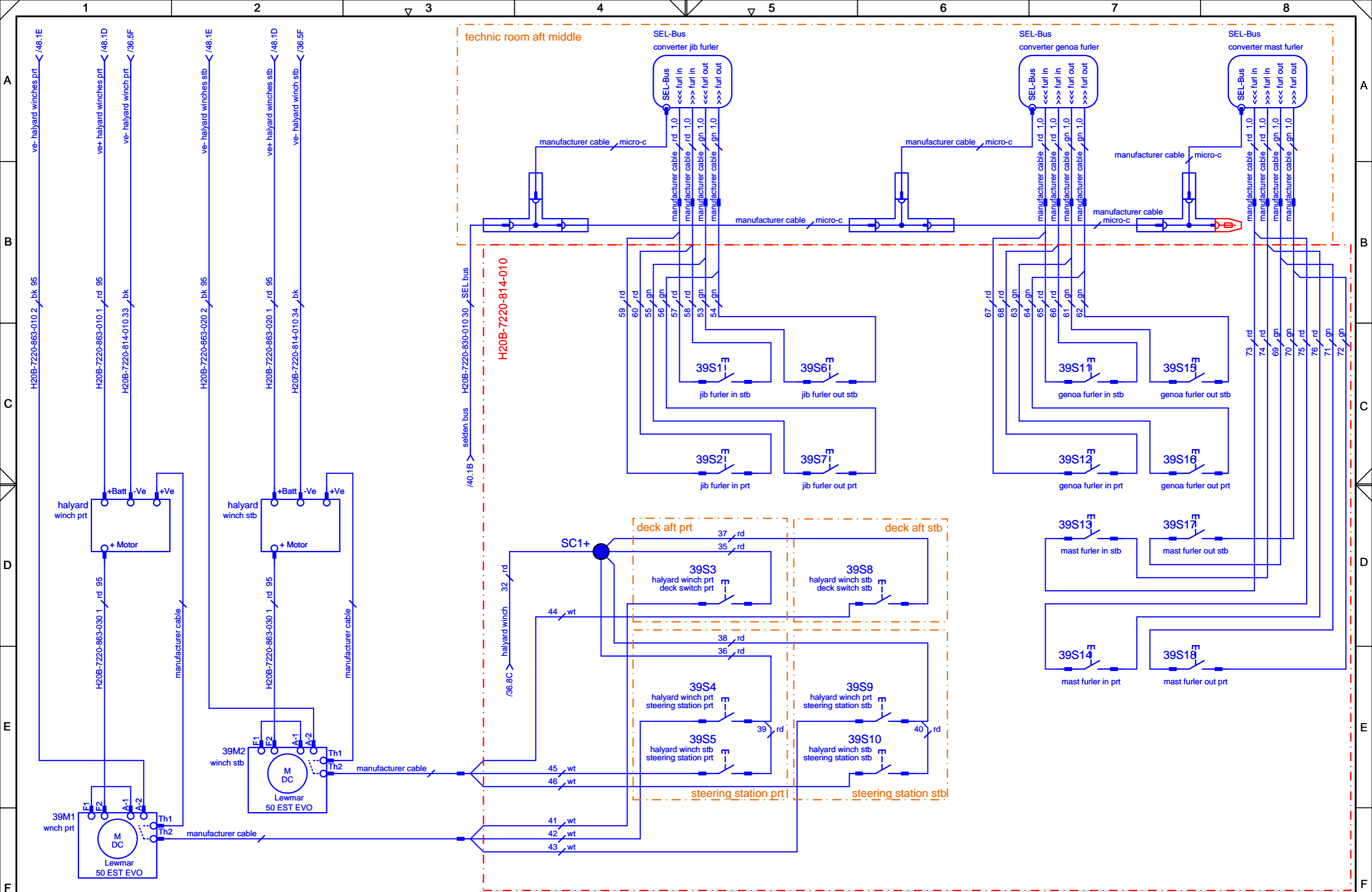

03	bp alarm added, watermaker updated	27.06.2022	DW	Datum	21.06.2021
02	changes solar panels; bathing platform	27.01.2022	JT	Gezeichnet	JTaubert
01	changes AC panel, battery protection, many changes	19.11.2021	JT	Geprüft	JTaubert
Rev.	Änderung	Datum	Name	Genehmigt	JTaubert



Hanse Yachts AG
Ladebower Chaussee 11
17493 Greifswald

DC Circuits
halyard winches, furler switches

Hanse 460		H20B-7215-100-010 -03		Blatt: 39
				von 54 Bl.

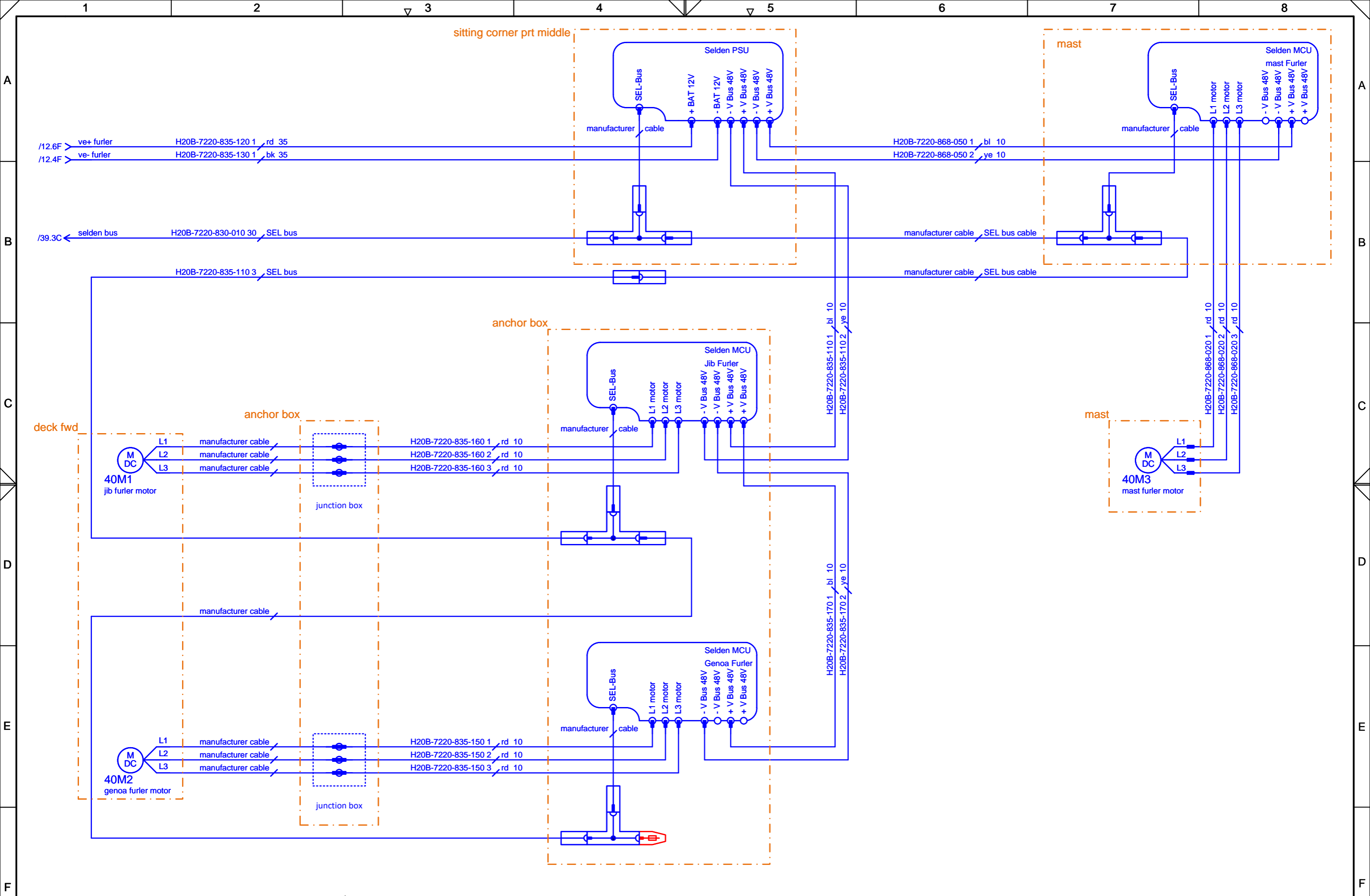

03	bp alarm added, watermaker updated	27.06.2022	DW	Datum	21.06.2021
02	changes solar panels; bathing platform	27.01.2022	JT	Gezeichnet	JTaubert
01	changes AC panel, battery protection, many changes	19.11.2021	JT	Geprüft	JTaubert
Rev.	Änderung	Datum	Name	Genehmigt	JTaubert

Hanse 

Hanse Yachts AG
Salinenstr. 22
17489 Greifswald

DC Circuits
furler control, furler motors

=		Blatt: 40	
+		von 54 Bl.	
Hanse 460	H20B-7215-100-010-Vorabfreigabe00		

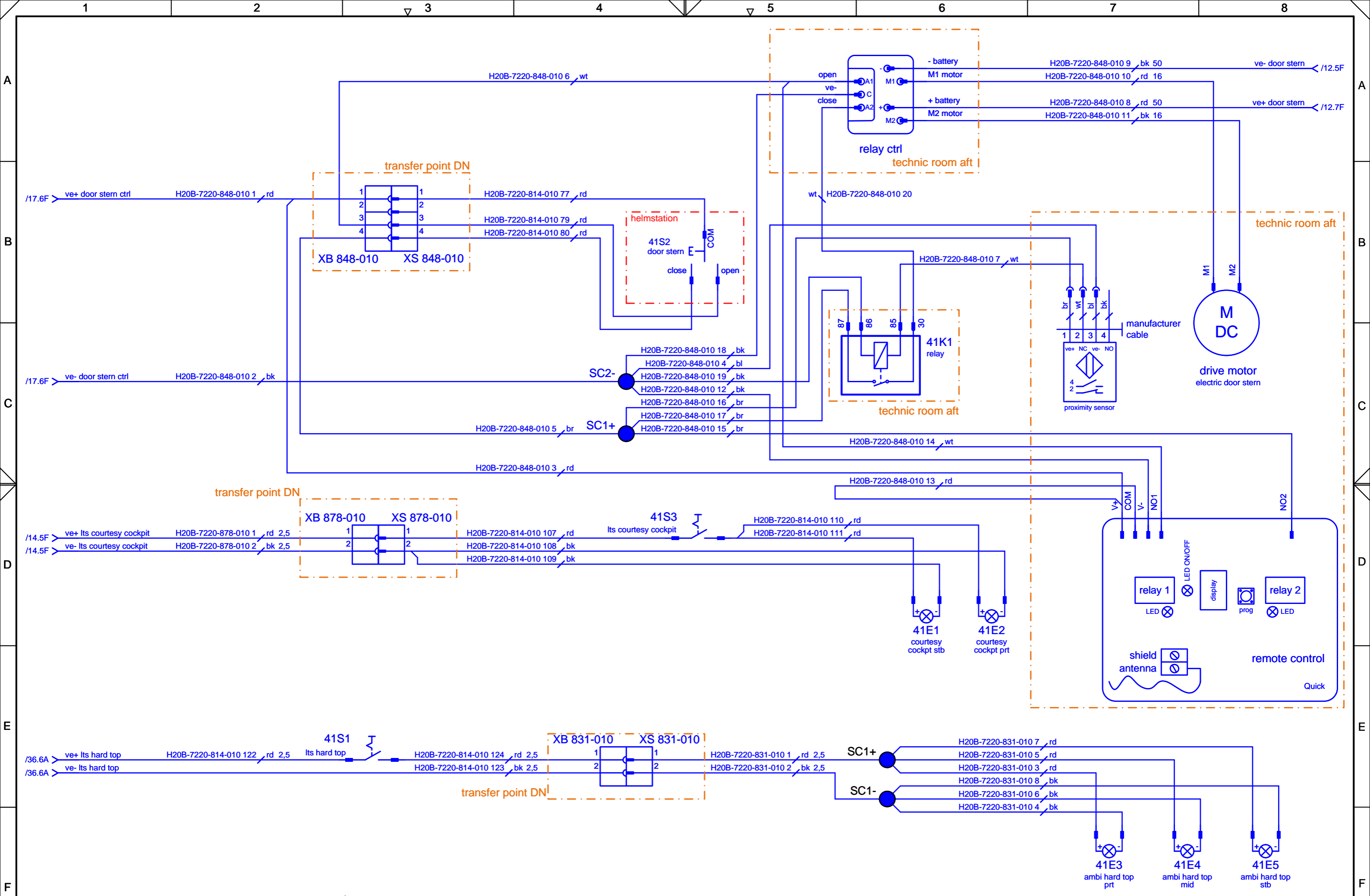

03	bp alarm added, watermaker updated	27.06.2022	DW	Datum	21.06.2021
02	changes solar panels; bathing platform	27.01.2022	JT	Gezeichnet	JTaubert
01	changes AC panel, battery protection, many changes	19.11.2021	JT	Geprüft	JTaubert
Rev.	Änderung	Datum	Name	Genehmigt	JTaubert

Hanse Yachts AG
 Salinenstr. 22
 17489 Greifswald

DC Circuits
 door stern, Its courtesy cockpit, Its flexi teak, Its hard top

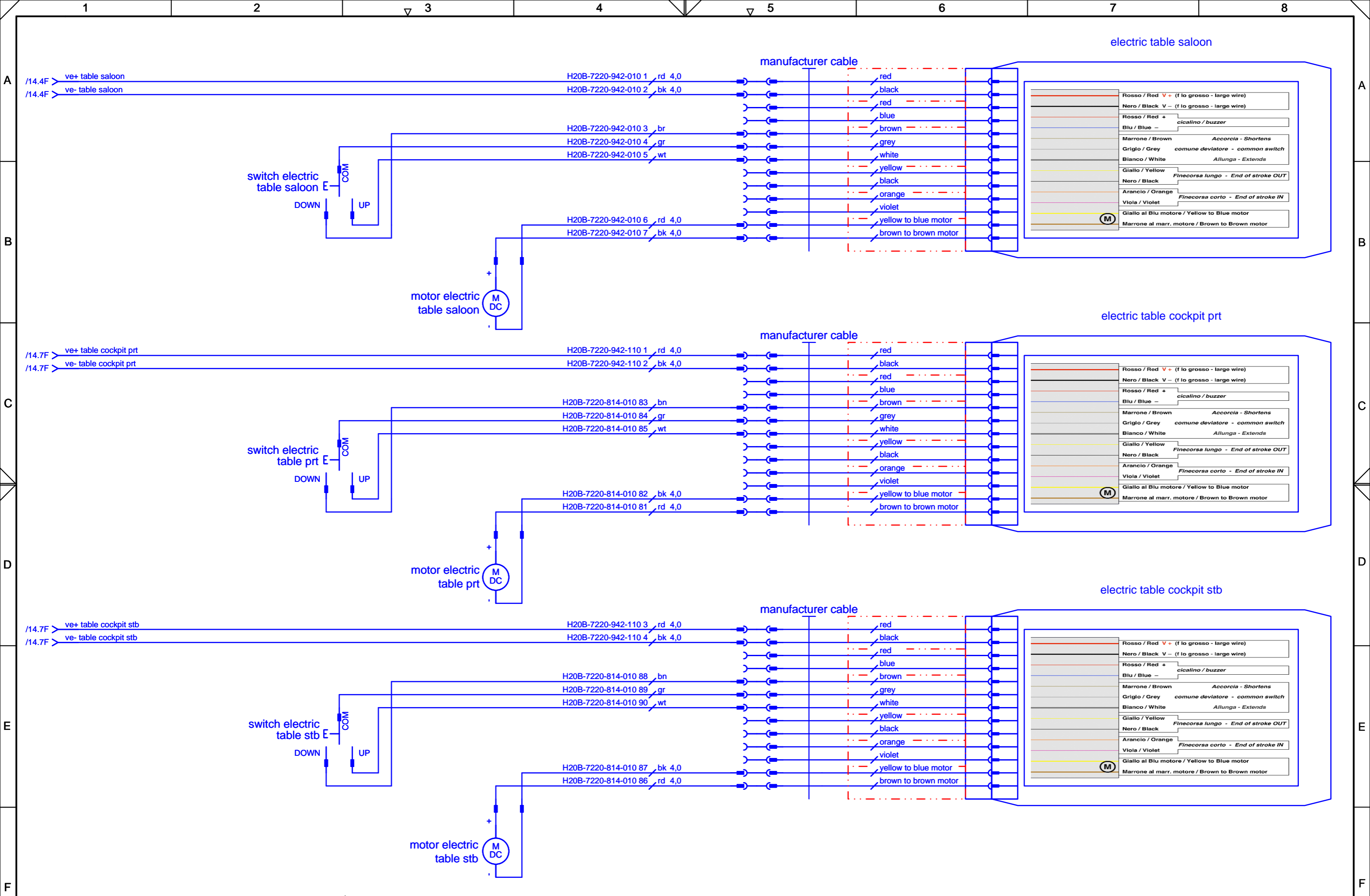

03	bp alarm added, watermaker updated	27.06.2022	DW	Datum	21.06.2021
02	changes solar panels; bathing platform	27.01.2022	JT	Gezeichnet	JTaubert
01	changes AC panel, battery protection, many changes	19.11.2021	JT	Geprüft	JTaubert
Rev.	Änderung	Datum	Name	Genehmigt	JTaubert

Hanse

Hanse Yachts AG
Salinenstr. 22
17489 Greifswald

DC Circuits
electric tables

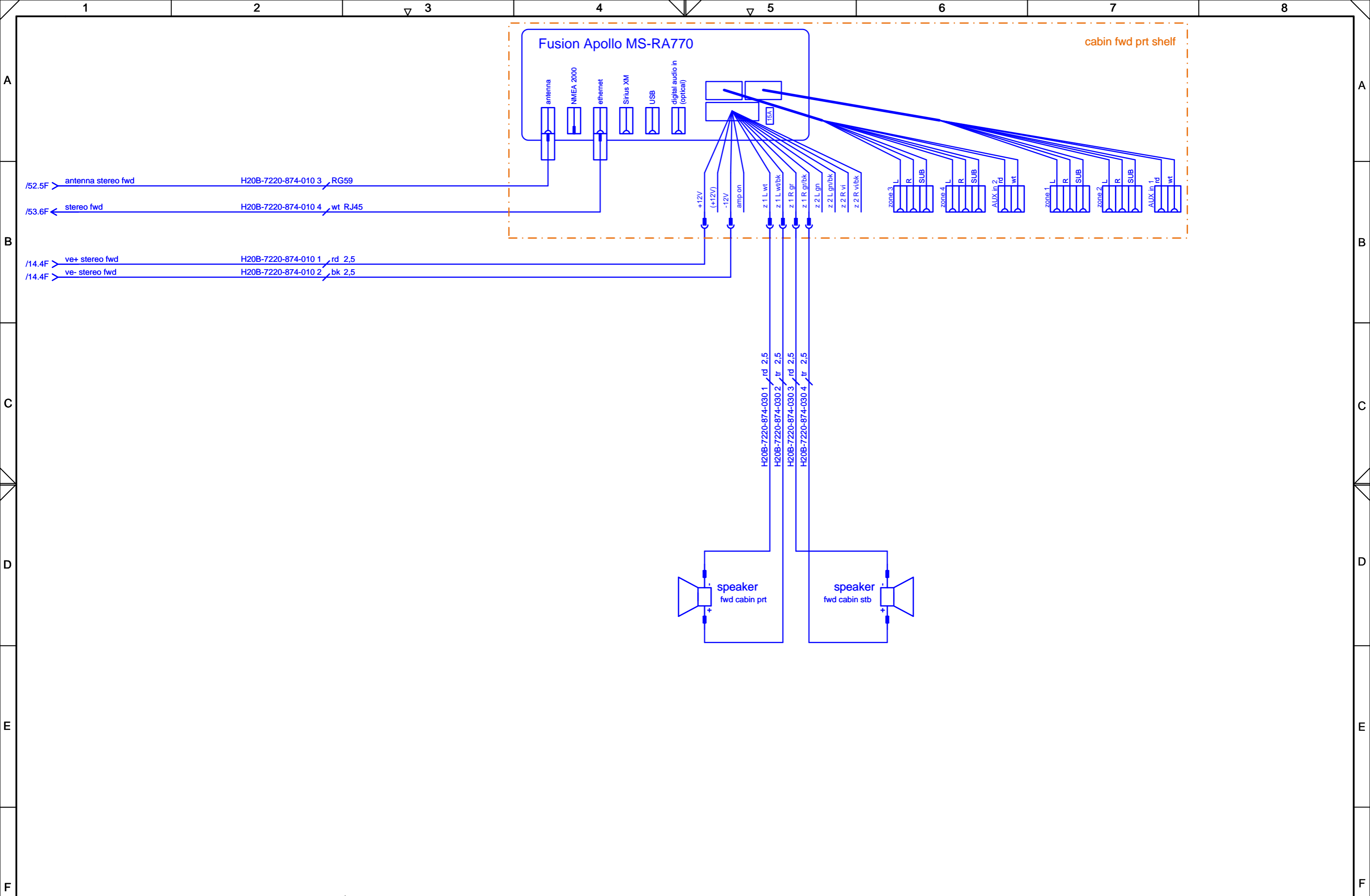

03	bp alarm added, watermaker updated	27.06.2022	DW	Datum	21.06.2021
02	changes solar panels; bathing platform	27.01.2022	JT	Gezeichnet	JTaubert
01	changes AC panel, battery protection, many changes	19.11.2021	JT	Geprüft	JTaubert
Rev.	Änderung	Datum	Name	Genehmigt	JTaubert



Hanse Yachts AG
Ladebower Chaussee 11
17493 Greifswald

DC Circuits
stereo fusion fwd

Hanse 460		H20B-7215-100-010 -03		Blatt: 43
				von 54 Bl.

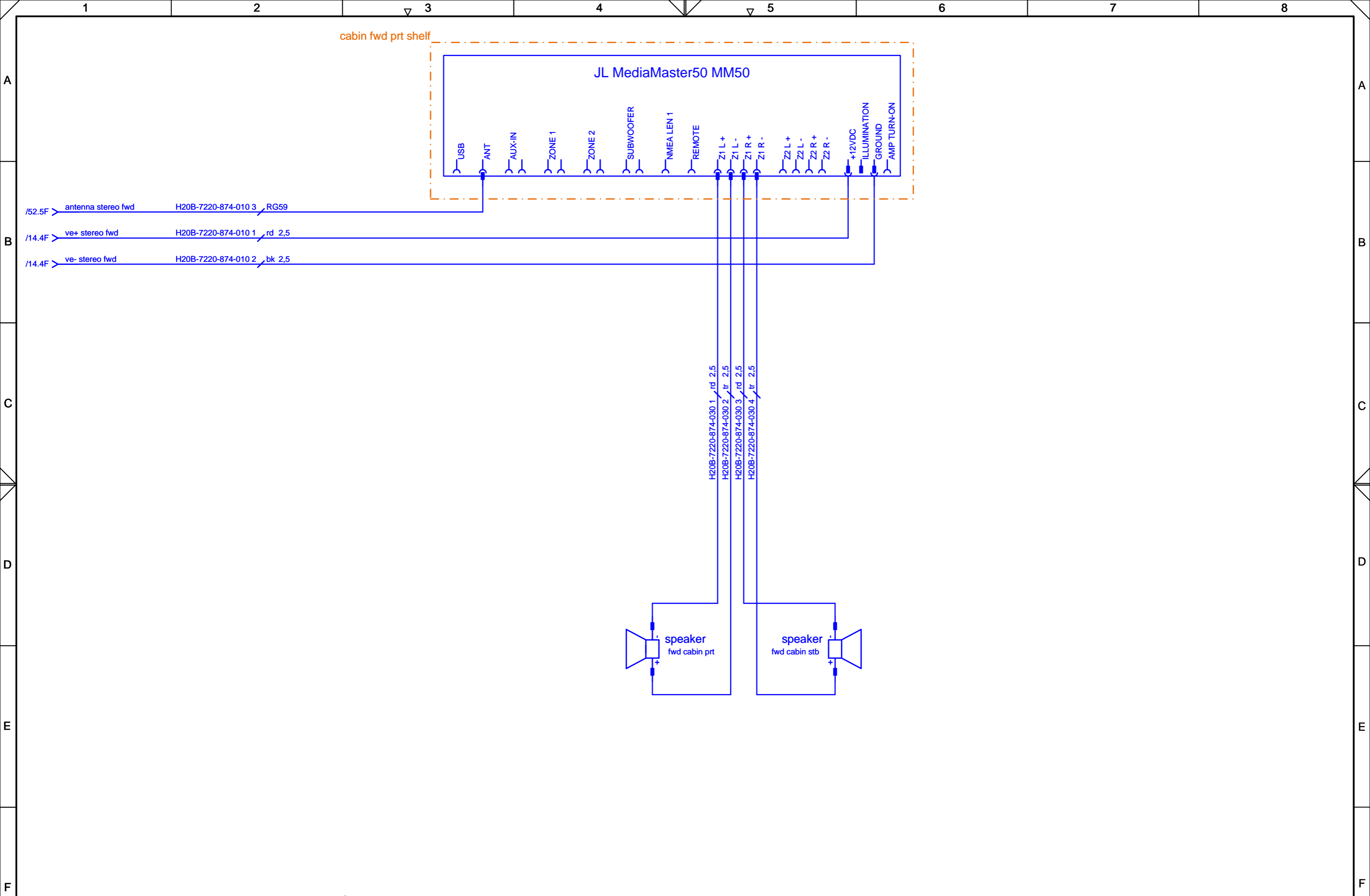

03	bp alarm added, watermaker updated	27.06.2022	DW	Datum	21.06.2021
02	changes solar panels; bathing platform	27.01.2022	JT	Gezeichnet	JTaubert
01	changes AC panel, battery protection, many changes	19.11.2021	JT	Geprüft	JTaubert
Rev.	Änderung	Datum	Name	Genehmigt	JTaubert



Hanse Yachts AG
Ladebower Chaussee 11
17493 Greifswald

DC Circuits
stereo JL fwd

=			
+			
Hanse 460		H20B-7215-100-010 -03	
		Blatt: 44	
		von 54 Bl.	

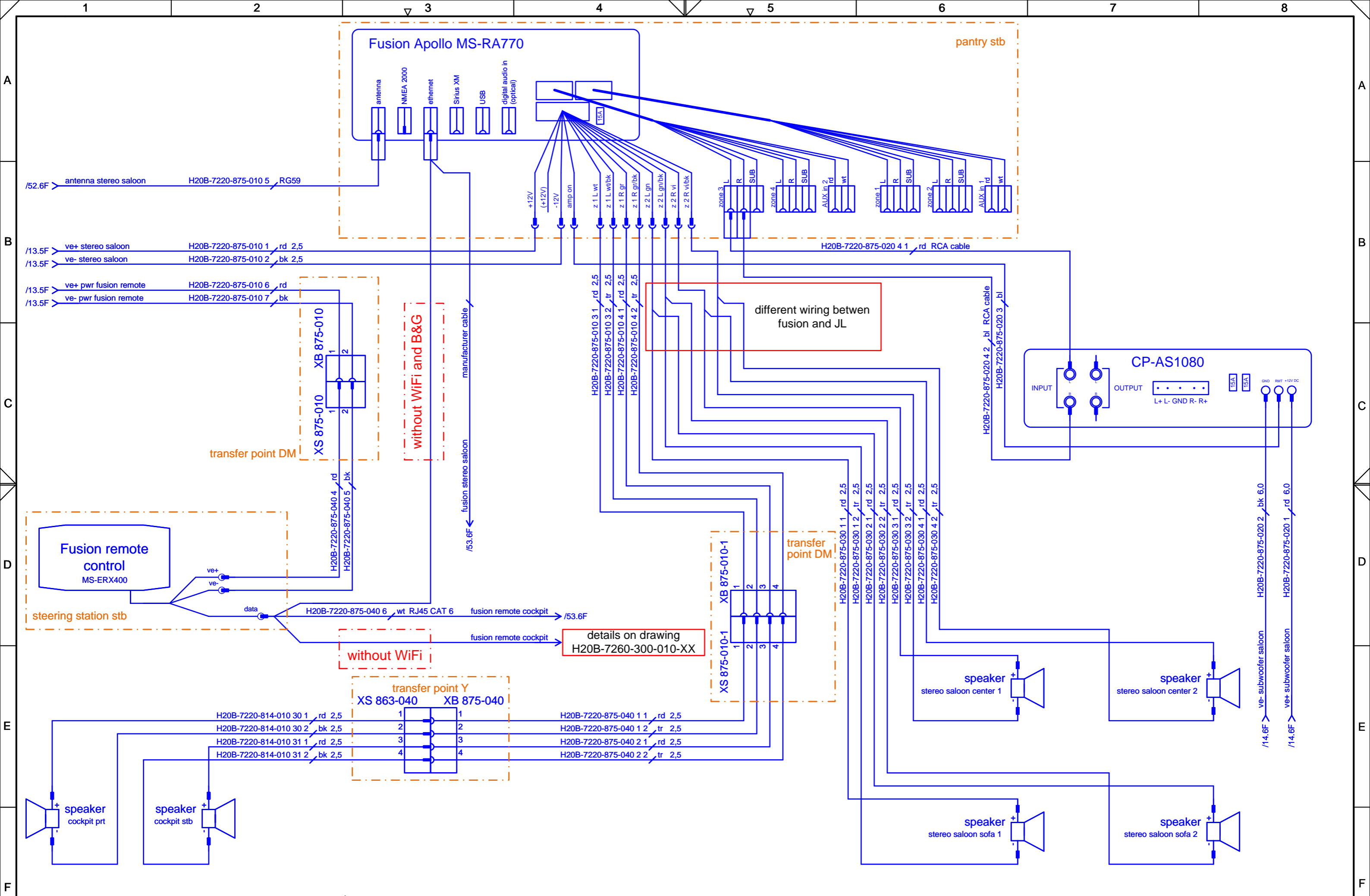

03	bp alarm added, watermaker updated	27.06.2022	DW	Datum	21.06.2021
02	changes solar panels; bathing platform	27.01.2022	JT	Gezeichnet	JTaubert
01	changes AC panel, battery protection, many changes	19.11.2021	JT	Geprüft	JTaubert
Rev.	Änderung	Datum	Name	Genehmigt	JTaubert



 Hanse Yachts AG
 Ladebower Chaussee 11
 17493 Greifswald

DC Circuits
stereo fusion saloon / cockpit

Hanse 460	H20B-7215-100-010 -03	Blatt: 45
		von 54 Bl.

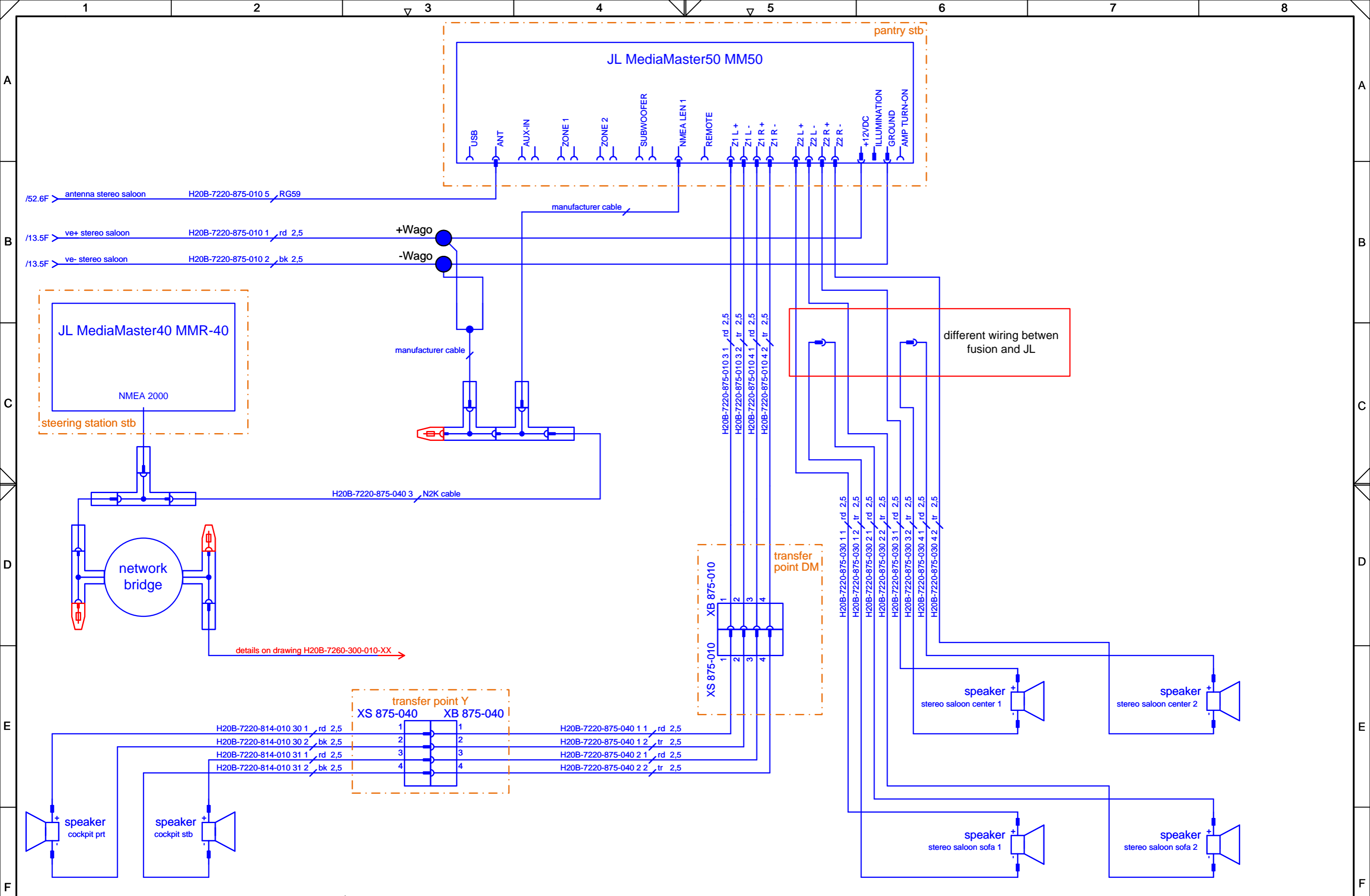

03	bp alarm added, watermaker updated	27.06.2022	DW	Datum	21.06.2021
02	changes solar panels; bathing platform	27.01.2022	JT	Gezeichnet	JTaubert
01	changes AC panel, battery protection, many changes	19.11.2021	JT	Geprüft	JTaubert
Rev.	Änderung	Datum	Name	Genehmigt	JTaubert

 Hanse Yachts AG
 Ladebower Chaussee 11
 17493 Greifswald

DC Circuits
 stereo JL saloon / cockpit

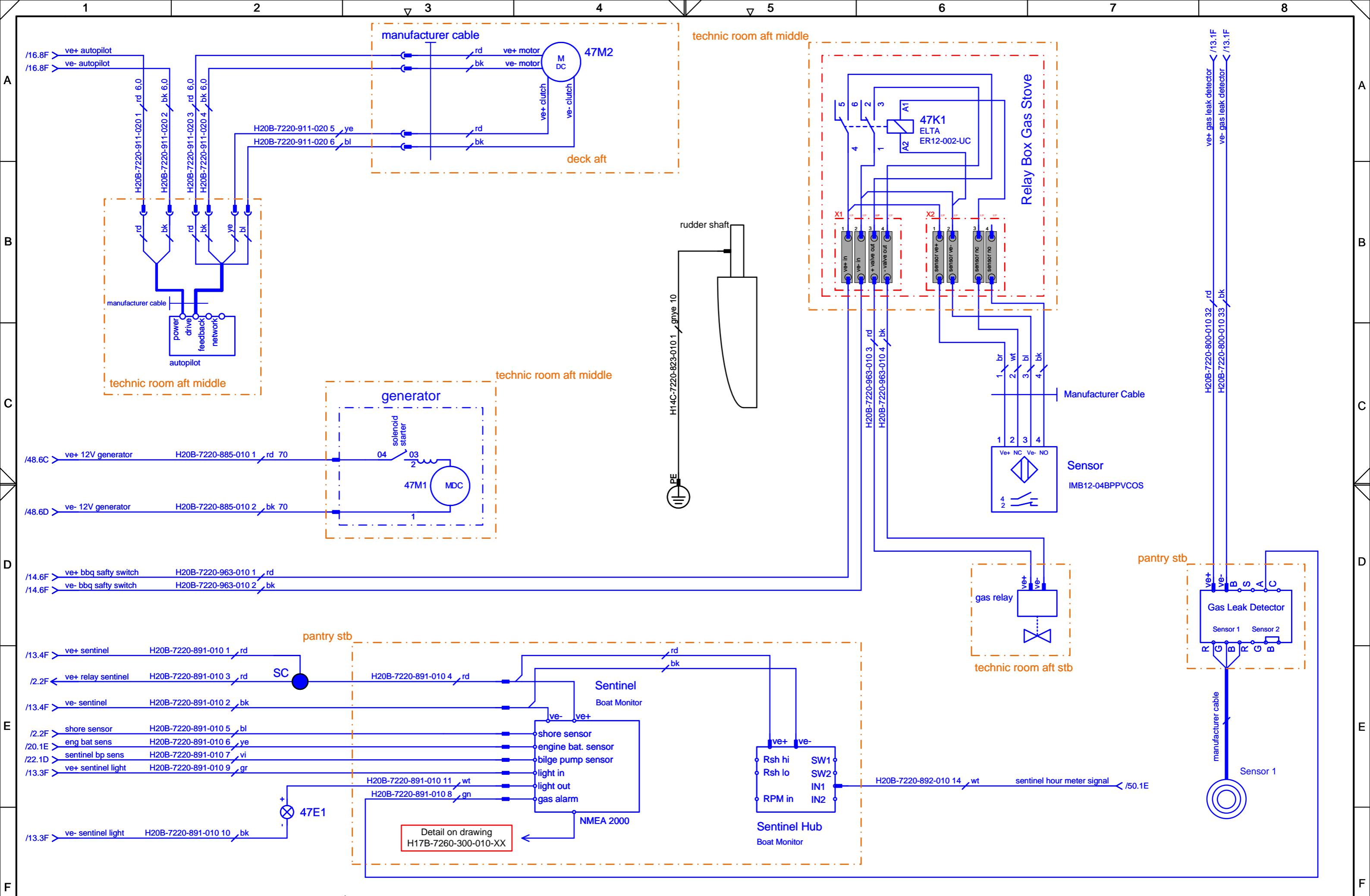

03	bp alarm added, watermaker updated	27.06.2022	DW	Datum	21.06.2021
02	changes solar panels; bathing platform	27.01.2022	JT	Gezeichnet	JTaubert
01	changes AC panel, battery protection, many changes	19.11.2021	JT	Geprüft	JTaubert
Rev.	Änderung	Datum	Name	Genehmigt	JTaubert



Hanse Yachts AG
Ladebower Chaussee 11
17493 Greifswald

DC Circuits
autopilot, DC generator, sentinel,
gas box, gas leak detector

=			
+			
Hanse 460		H20B-7215-100-010 -03	
		Blatt: 47	
		von 54 Bl.	

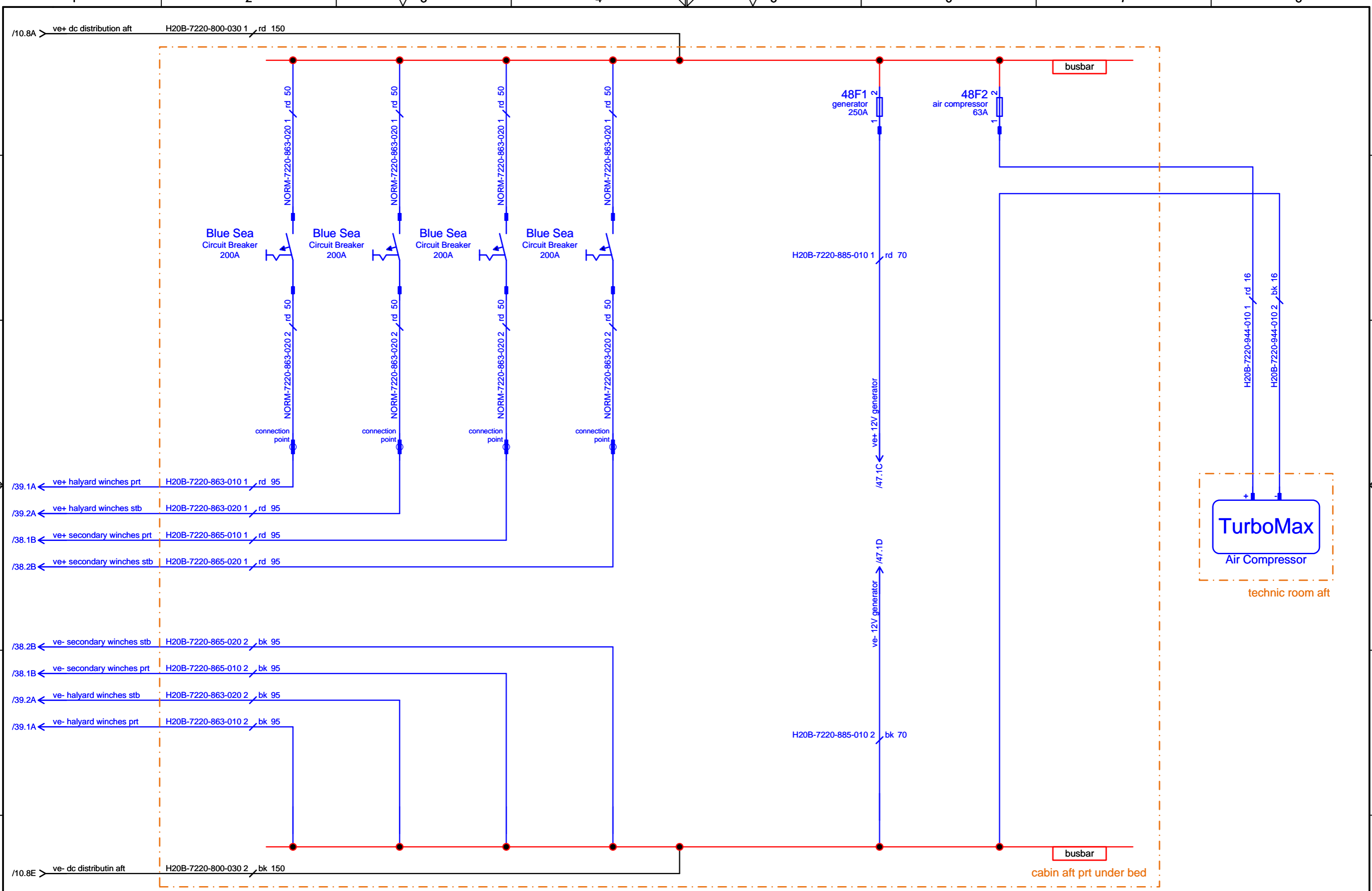

03	bp alarm added, watermaker updated	27.06.2022	DW	Datum	21.06.2021
02	changes solar panels; bathing platform	27.01.2022	JT	Gezeichnet	JTaubert
01	changes AC panel, battery protection, many changes	19.11.2021	JT	Geprüft	JTaubert
Rev.	Änderung	Datum	Name	Genehmigt	JTaubert



Hanse Yachts AG
Ladebower Chaussee 11
17493 Greifswald

DC Circuits
DC distribution aft

=			
+			
Hanse 460		H20B-7215-100-010 -03	
		Blatt: 48	
		von 54 Bl.	

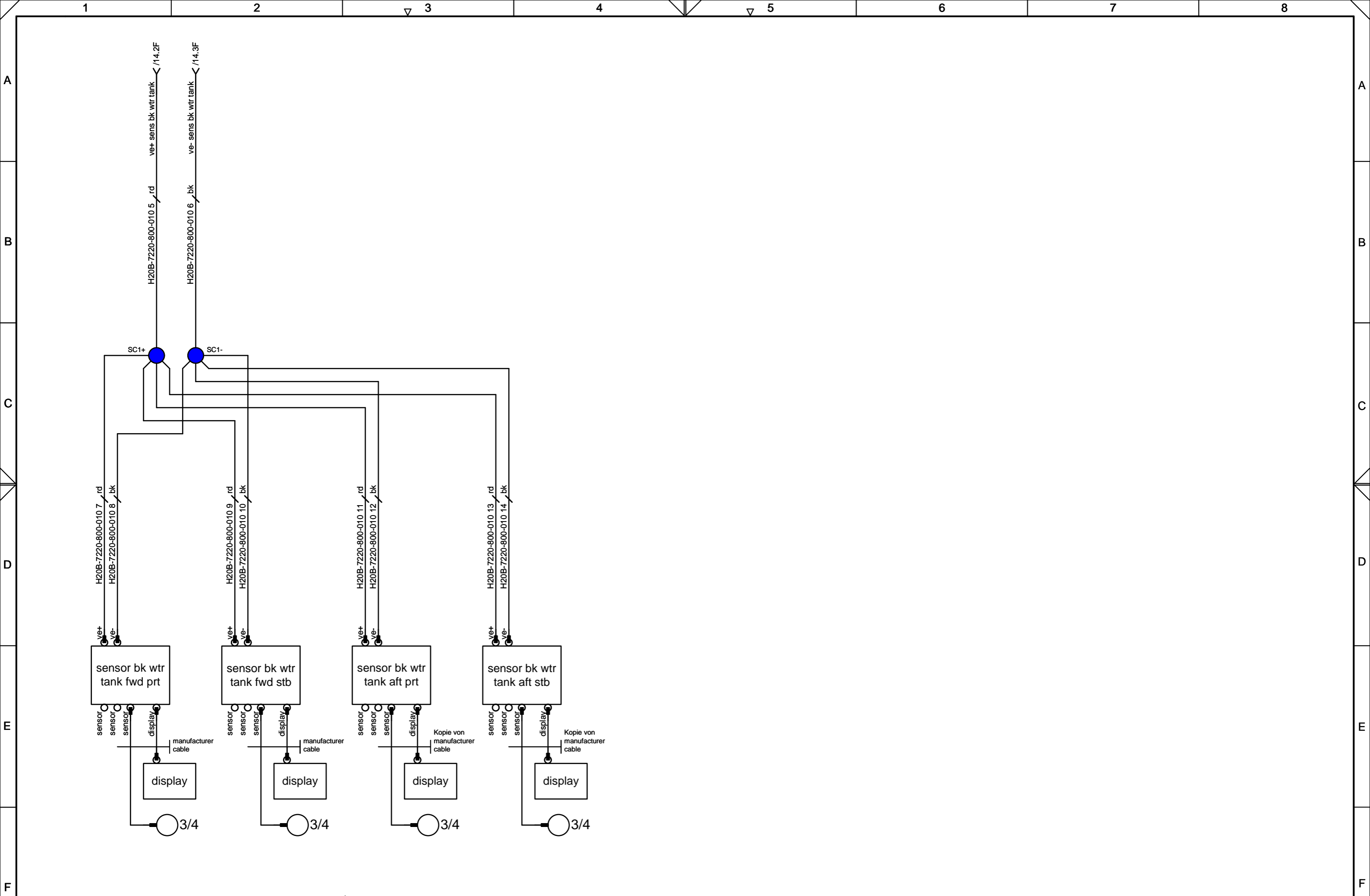

03	bp alarm added, watermaker updated	27.06.2022	DW	Datum	21.06.2021
02	changes solar panels; bathing platform	27.01.2022	JT	Gezeichnet	JTaubert
01	changes AC panel, battery protection, many changes	19.11.2021	JT	Geprüft	JTaubert
Rev.	Änderung	Datum	Name	Genehmigt	JTaubert



Hanse Yachts AG
Ladebower Chaussee 11
17493 Greifswald

DC Circuits
black water tank sensor

=		Blatt: 49
+		
Hanse 460	H20B-7215-100-010 -03	von 54 Bl.

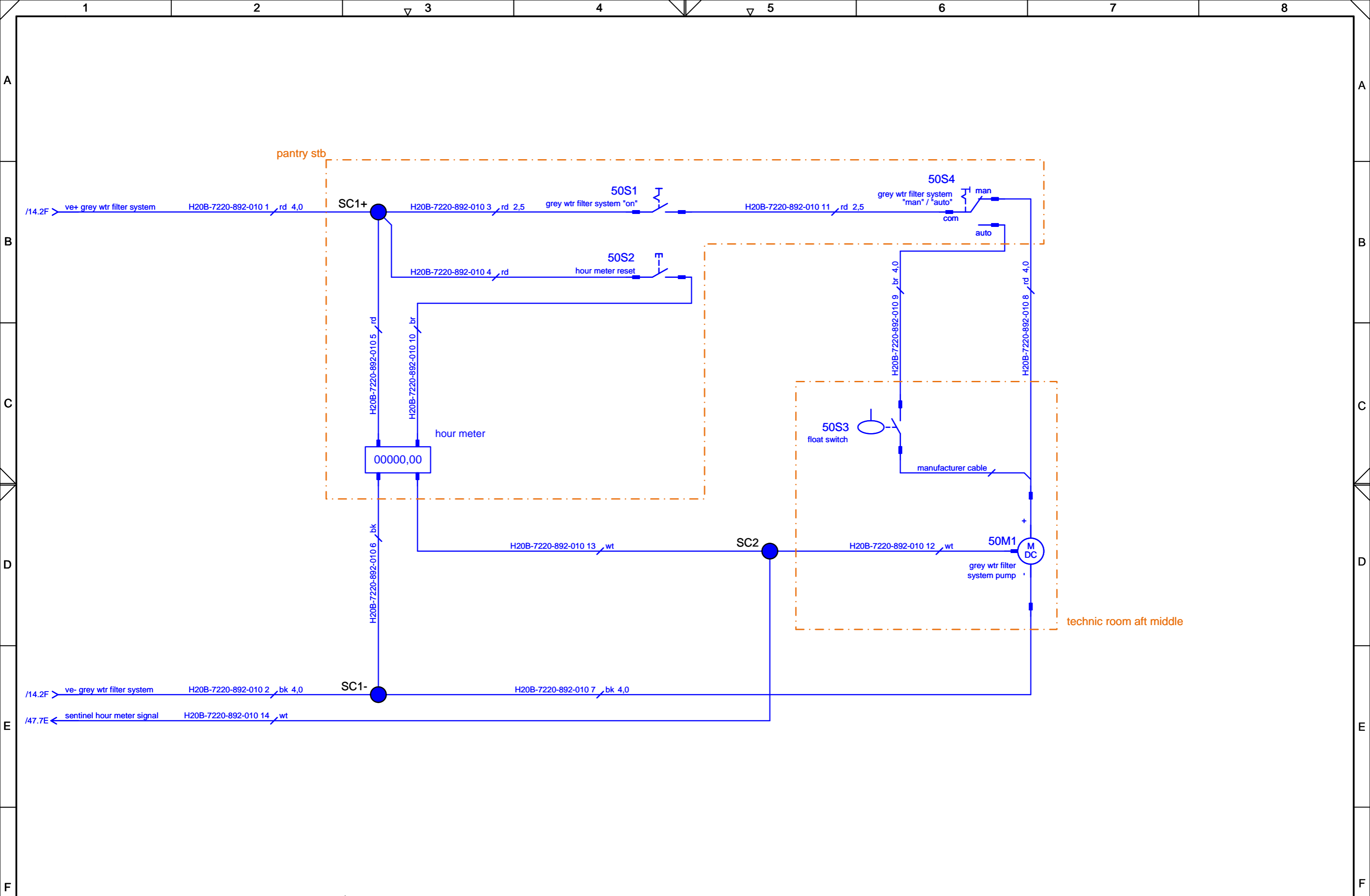

03	bp alarm added, watermaker updated	27.06.2022	DW	Datum	21.06.2021
02	changes solar panels; bathing platform	27.01.2022	JT	Gezeichnet	JTaubert
01	changes AC panel, battery protection, many changes	19.11.2021	JT	Geprüft	JTaubert
Rev.	Änderung	Datum	Name	Genehmigt	JTaubert



Hanse Yachts AG
Ladebower Chaussee 11
17493 Greifswald

DC Circuits
grey water filter system

=			
+			
Hanse 460		H20B-7215-100-010 -03	
		Blatt: 50	
		von 54 Bl.	

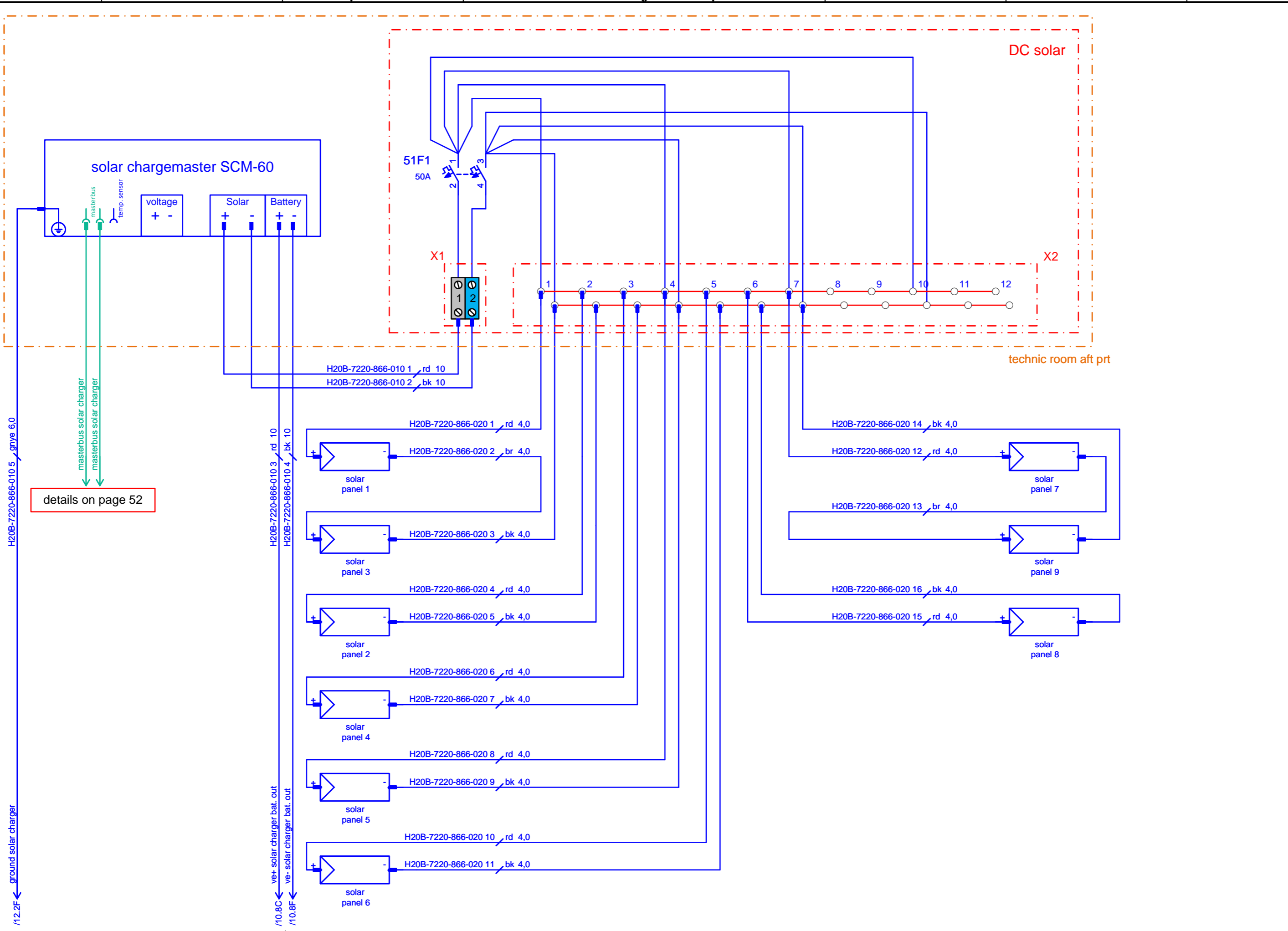

03	bp alarm added, watermaker updated	27.06.2022	DW	Datum	21.06.2021
02	changes solar panels; bathing platform	27.01.2022	JT	Gezeichnet	JTaubert
01	changes AC panel, battery protection, many changes	19.11.2021	JT	Geprüft	JTaubert
Rev.	Änderung	Datum	Name	Genehmigt	JTaubert



Hanse Yachts AG
Ladebower Chaussee 11
17493 Greifswald

DC Circuits solar

Hanse 460		H20B-7215-100-010 -03		Blatt: 51
				von 54 Bl.

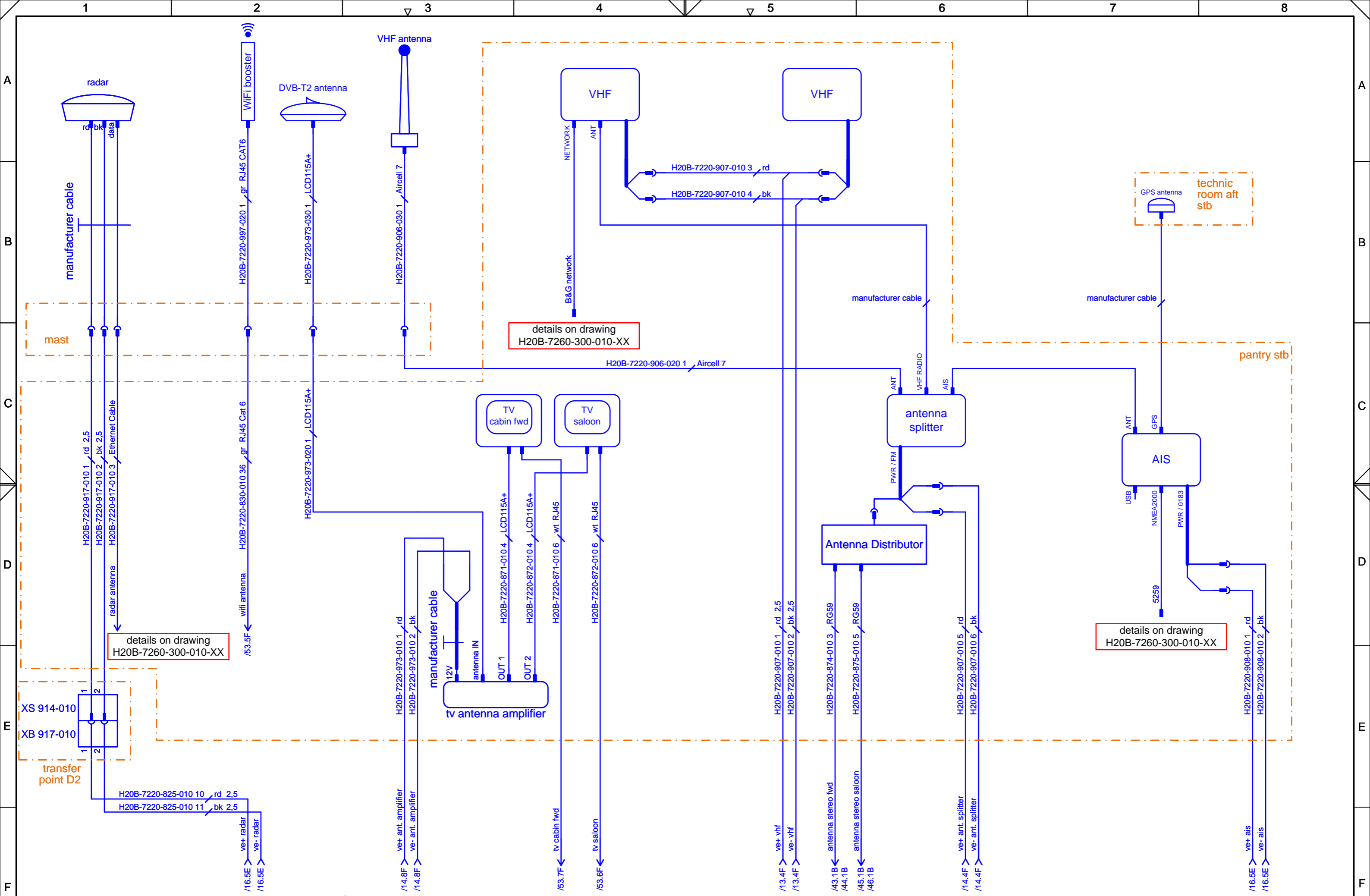

03	bp alarm added, watermaker updated	27.06.2022	DW	Datum	21.06.2021
02	changes solar panels; bathing platform	27.01.2022	JT	Gezeichnet	JTaubert
01	changes AC panel, battery protection, many changes	19.11.2021	JT	Geprüft	JTaubert
Rev.	Änderung	Datum	Name	Genehmigt	JTaubert



 Hanse Yachts AG
 Ladebower Chaussee 11
 17493 Greifswald

DC Circuits
 antenna overview

Hanse 460	H20B-7215-100-010 -03	Blatt: 52
		von 54 Bl.

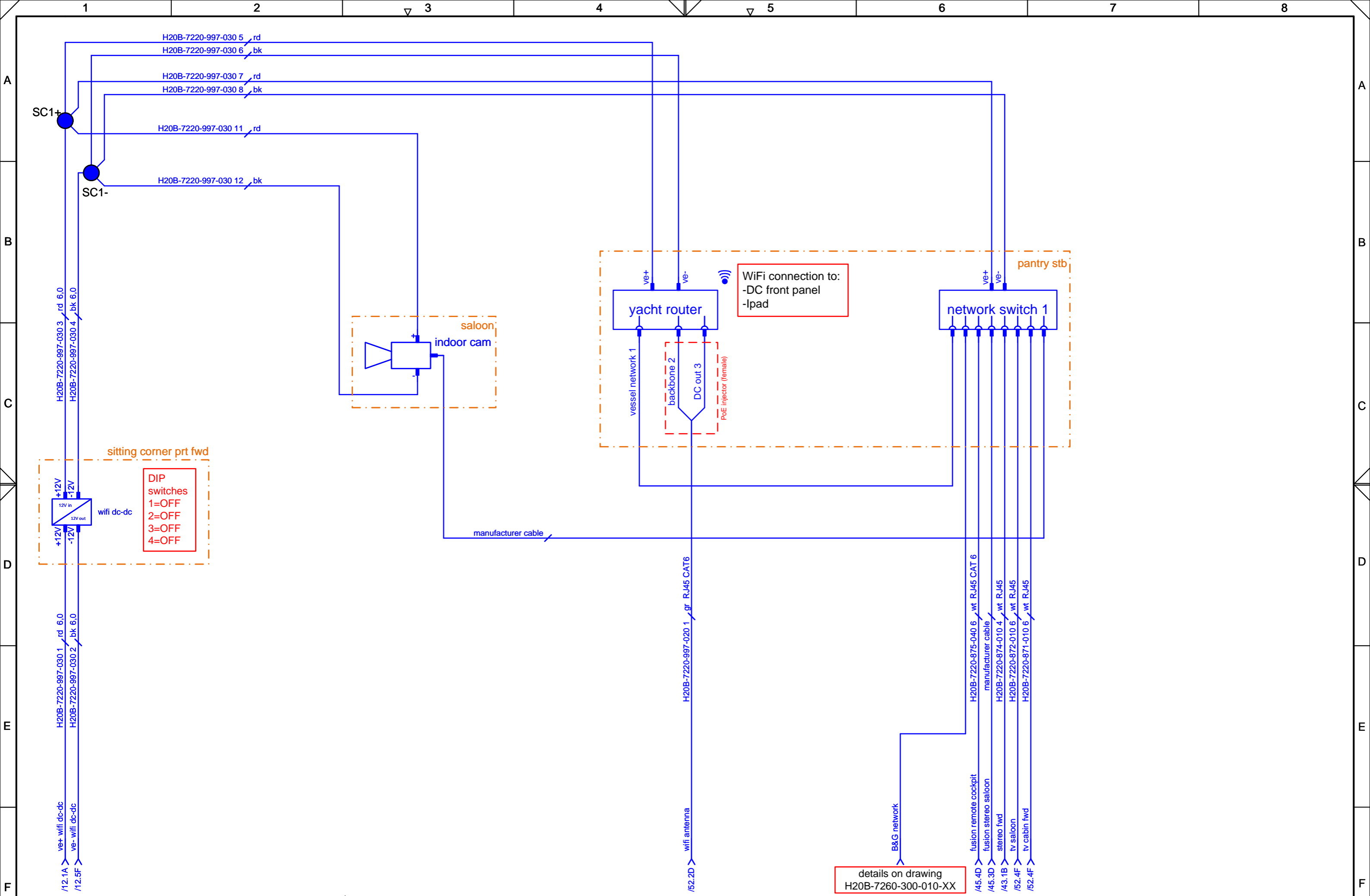

03	bp alarm added, watermaker updated	27.06.2022	DW	Datum	21.06.2021
02	changes solar panels; bathing platform	27.01.2022	JT	Gezeichnet	JTaubert
01	changes AC panel, battery protection, many changes	19.11.2021	JT	Geprüft	JTaubert
Rev.	Änderung	Datum	Name	Genehmigt	JTaubert



Hanse Yachts AG
Ladebower Chaussee 11
17493 Greifswald

DC Circuits
network overview

Hanse 460		H20B-7215-100-010 -03		Blatt: 53
				von 54 Bl.

details on drawing
H20B-7260-300-010-XX

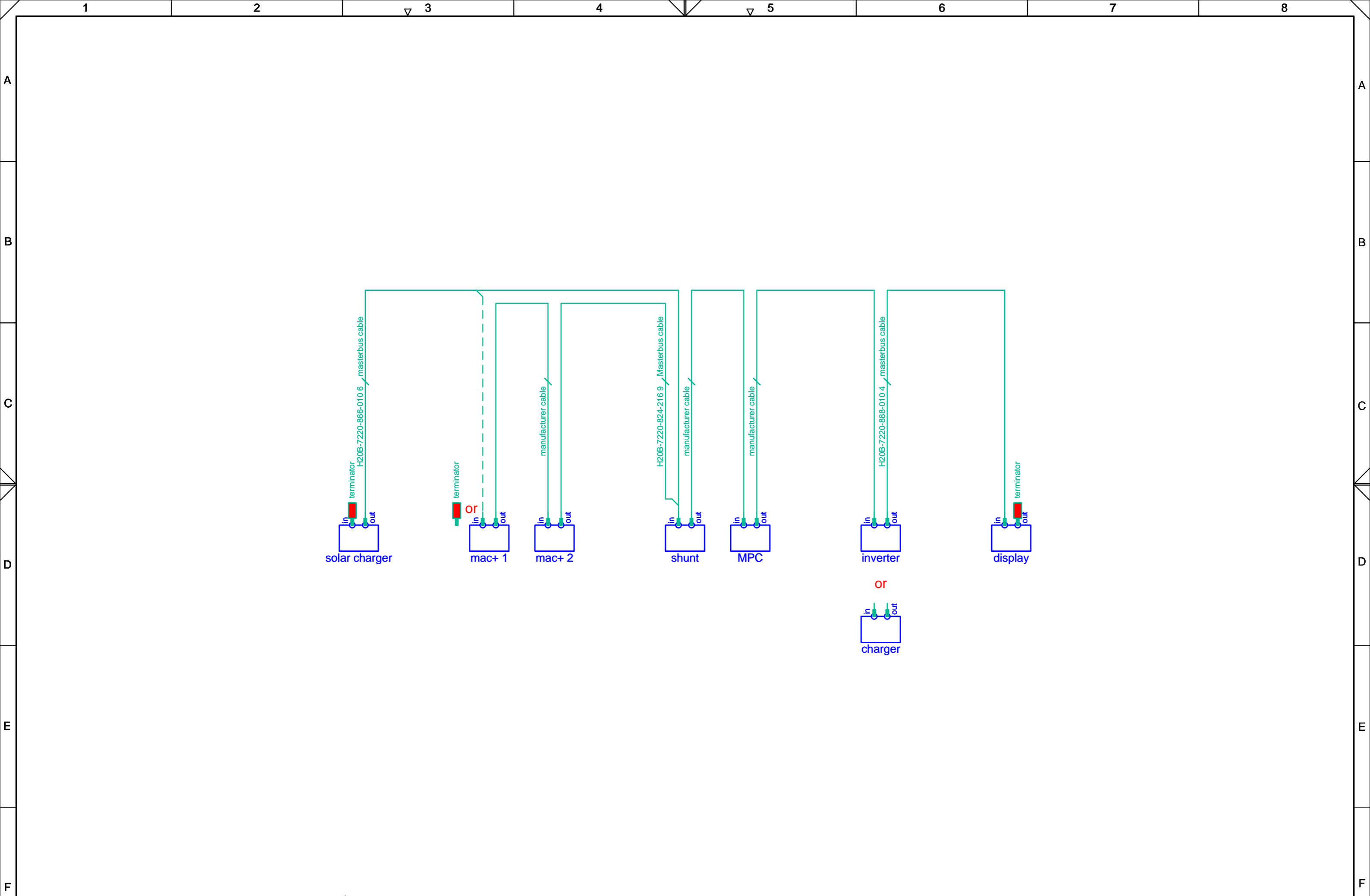

03	bp alarm added, watermaker updated	27.06.2022	DW	Datum	21.06.2021
02	changes solar panels; bathing platform	27.01.2022	JT	Gezeichnet	JTaubert
01	changes AC panel, battery protection, many changes	19.11.2021	JT	Geprüft	JTaubert
Rev.	Änderung	Datum	Name	Genehmigt	JTaubert



Hanse Yachts AG
Ladebower Chaussee 11
17493 Greifswald

DC Circuits
masterbus overview

		=	
		+	
Hanse 460		H20B-7215-100-010 -03	Blatt: 54
			von 54 Bl.