

LOWRANCE

SIMRAD

B&G

NSPL-500

AIS/VHF antenna splitter

User Manual

ENGLISH

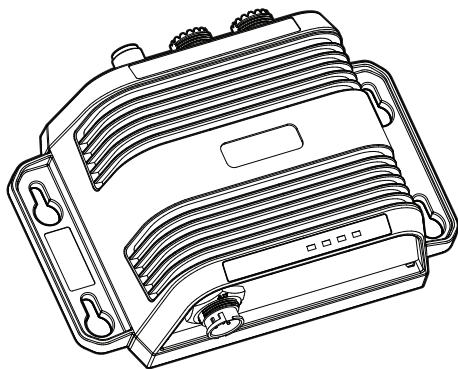

Preface

As Navico is continuously improving this product, we retain the right to make changes to the product at any time which may not be reflected in this version of the manual. Please contact your nearest distributor if you require any further assistance.

It is the owner's sole responsibility to install and use the antenna splitter in a manner that will not cause accidents, personal injury or property damage. The user of this product is solely responsible for observing safe boating practices.

NAVICO HOLDING AS AND ITS SUBSIDIARIES, BRANCHES AND AFFILIATES DISCLAIM ALL LIABILITY FOR ANY USE OF THIS PRODUCT IN A WAY THAT MAY CAUSE ACCIDENTS, DAMAGE OR THAT MAY VIOLATE THE LAW.

Governing Language: This statement, any instruction manuals, user guides and other information relating to the product (Documentation) may be translated to, or has been translated from, another language (Translation). In the event of any conflict between any Translation of the Documentation, the English language version will be the official version of the Documentation.

This manual represents the product as at the time of printing. Navico Holding AS and its subsidiaries, branches and affiliates reserve the right to make changes to specifications without notice.

Copyright

Copyright © 2017 Navico Holding AS.

Warranty

The warranty card is supplied as a separate document.

About this manual

Meet the technical standards in accordance with

- FCC 47 CFR Part 15 B
- comply with CE under EMC directive 2014/53/EU RED

For more information, please refer to the brand websites:
www.bandg.com
www.lowrance.com
www.simrad-yachting.com

Important text that requires special attention from the reader is emphasized as follows:

→ **Note:** Used to draw the reader's attention to a comment or other important information.

 **Warning:** Used when necessary to warn personnel that they should proceed carefully to prevent risk of injury to personnel or damage to equipment.

Contents

4 Notices

- 4 Safety warnings
- 4 General notices
- 4 Compass safe distance
- 4 RF emissions notice
- 5 Warranty
- 5 Disposal of this product and packaging

6 About your AIS/VHF antenna splitter

- 6 About AIS
- 7 What's in the box?
- 8 Electrical connections

9 Installation

- 9 Preparing for installation
- 9 VHF antenna
- 9 VHF radio
- 10 AIS transceiver
- 10 FM radio
- 10 Power cable
- 10 Installation procedures

16 Operation

- 16 Indicator functions

17 Troubleshooting

18 Specifications

Table of figures

7	Figure 1	Items included with the product
8	Figure 2	AIS/VHF antenna splitter overview
9	Figure 3	Typical installation configuration
11	Figure 4	NSPL-500 dimensions
12	Figure 5	NSPL-500 mounting
12	Figure 6	Position of the VHF antenna connector
13	Figure 7	Position of the VHF radio connector
14	Figure 8	Position of the AIS transceiver connector
15	Figure 9	Connecting the power supply and optional FM output
16	Figure 10	Indicator location on the NSPL-500 unit

1

Notices

When reading this manual please pay particular attention to warnings marked with the warning triangle. These are important messages for safety, installation and usage of the product.

Safety warnings

⚠ Warning: This equipment must be installed in accordance with the instructions provided in this manual.

⚠ Warning: Only use this AIS/VHF antenna splitter in conjunction with an approved AIS Class B transceiver or receiver purchased from a reputable supplier.

⚠ Warning: Do not install this equipment in a flammable atmosphere such as in an engine room or near to fuel tanks.

General notices

Compass safe distance

The compass safe distance of this unit is 0.3 m.

RF emissions notice

The information provided in this section assumes the NSPL-500 is connected to an AIS Class B transceiver.

The warnings regarding RF emissions provided in the manual for the VHF radio being used with the NSPL-500 should also be noted prior to installation of the NSPL-500.

- **Note:** The NSPL-500 generates and radiates radio frequency electromagnetic energy. This equipment must be installed and operated according to the instructions contained in this manual. Failure to do so can result in personal injury and/or the malfunction of the NSPL-500 and/or the AIS transceiver it is connected to.
- **Note:** Never operate the NSPL-500 unless it is connected to a VHF antenna.
To maximize performance and minimize human exposure to radio frequency electromagnetic energy you must make sure that the

antenna is mounted at least 1.5 m away from the NSPL-500 and is connected to the NSPL-500 before power is applied.

The system has a Maximum Permissible Exposure (MPE) radius of 0.6 m. This has been determined assuming the maximum power of the AIS transceiver and using antennas with a maximum gain of 3 db.

The antenna should be mounted 3.5 m above the deck in order to meet RF exposure requirements. Higher gain antennas will require a greater MPE radius. Do not operate the unit when anyone is within the MPE radius of the antenna (unless they are shielded from the antenna field by a grounded metallic barrier). The antenna should not be co-located or operated in conjunction with any other transmitting antenna. The required antenna impedance is 50 ohms.

Warranty

This product is supplied with standard warranty as defined in the accompanying warranty information.

⚠ Warning: Any attempt to tamper with or damage the product will invalidate the warranty.

Disposal of this product and packaging

Please dispose of the NSPL-500 in accordance with the European WEEE Directive or with the applicable local regulations for disposal of electrical equipment.

Every effort has been made to ensure the packaging for this product is recyclable. Please dispose of the packaging in an environmentally friendly manner.

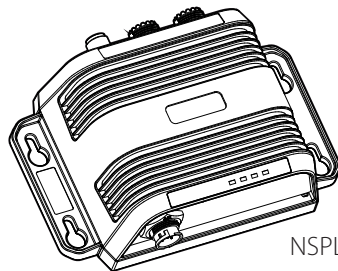

NSPL-500

2

About your AIS/VHF antenna splitter

About AIS

The marine Automatic Identification System (AIS) is a location and vessel information reporting system. It allows vessels equipped with AIS to automatically and dynamically share and regularly update their position, speed, course and other information such as vessel identity with similarly equipped vessels. Position is derived from the Global Positioning System (GPS) and communication between vessels is by Very High Frequency (VHF) digital transmissions.

There are a number of types of AIS device as follows:

- **Class A transceivers.** These are similar to class B transceivers but are designed to be fitted to large vessels such as cargo ships and large passenger vessels. Class A transceivers transmit at a higher VHF signal power than class B transceivers and therefore can be received by more distant vessels, and also transmit more frequently. Class A transceivers are mandatory on all vessels over 300 gross tonnes on international voyages and certain types of passenger vessels under the SOLAS mandate.
- **Class B transceivers.** Similar to class A transceivers in many ways, but are normally lower cost due to the less stringent performance requirements. Class B transceivers transmit at a lower power and at a lower reporting rate than class A transceivers.
- **AIS base stations.** AIS base stations are used by Vessel Traffic Systems to monitor and control the transmissions of AIS transceivers.
- **Aids to Navigation (AtoN) transceivers.** AtoNs are transceivers mounted on buoys or other hazards to shipping which transmit details of their location to the surrounding vessels.
- **AIS receivers.** AIS receivers will generally receive transmissions from class A transceivers, class B transceivers, AtoNs and AIS base stations but do not transmit any information about the vessel on which they are installed.

Because VHF radios and AIS devices operate within the same frequency range and therefore require the same type of VHF antenna it is possible to utilize a single VHF antenna for both devices by using an AIS/VHF antenna splitter.

The NSPL-500 is designed to work primarily with AIS class B transceivers, although it will operate equally well with AIS receivers.

⚠ Warning: This AIS/VHF antenna splitter must not be used with Class A transceivers, Aids to Navigation transceivers or AIS base stations.

What's in the box?

Figure 1 shows the items included with your NSPL-500 purchase. The following sections give a brief overview of each item. Please ensure all items are present and if any of the items are not present contact your dealer.

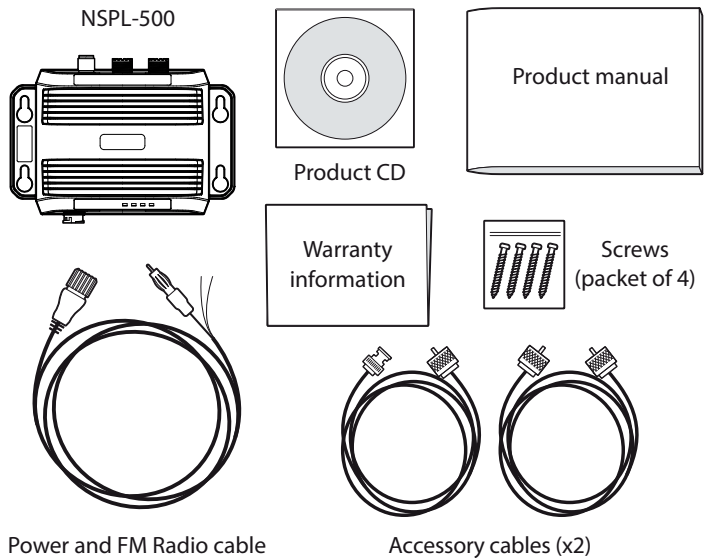

Figure 1 Items included with the product

- **Product manual**
The product manual is this document and should be read thoroughly prior to any attempt to install or use the NSPL-500.
- **VHF radio connection cable**
This cable is used to connect a VHF radio to the NSPL-500. The cable has PL259 connectors at either end and requires a SO239 connector on the VHF radio. If your VHF radio does not have a SO239 connector please contact your dealer for details of suitable adaptors.
- **AIS transceiver connection cable**
This cable is used to connect a Class-B AIS transceiver, such as the NAIS-500 to the NSPL-500. The cable has a BNC connector at one

end (for connection to the NSPL-500) and a PL259 connection at the opposite end (for connection to the AIS transceiver).

- NSPL-500 AIS/VHF antenna splitter unit

Figure 2 shows an overview of the NSPL-500 unit.

The NSPL-500 has a number of indicators which provide information to the user about the status of the NSPL-500. Please refer to section 4 for more details of the indicator functions.

The NSPL-500 mounting holes are located as shown in Figure 2. Please refer to the Installation procedure section for details of how to mount the NSPL-500.

- Power and FM cable

The power and FM cable connects to the NSPL-500 and enables connection to power and an FM radio antenna input.

Electrical connections

The NSPL-500 has the following electrical connections as shown in Figure 2.

- Power supply
- VHF antenna connector
- VHF radio connector
- AIS transceiver connector
- FM radio connector

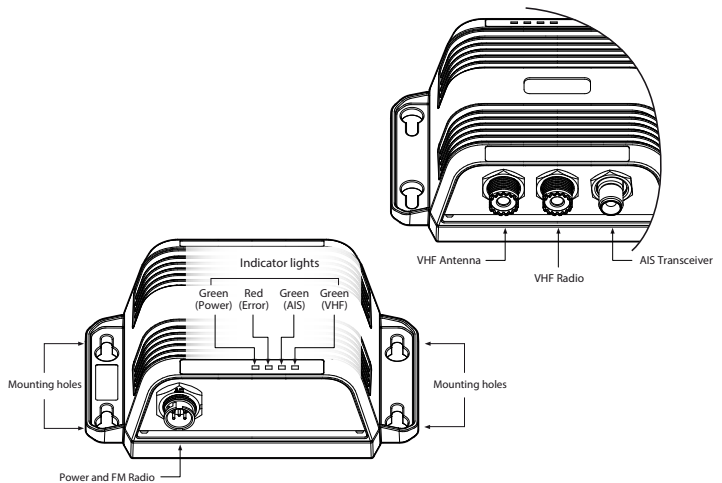

Figure 2 AIS/VHF antenna splitter overview

3

Installation

Preparing for installation

Figure 3 shows a typical installation configuration for the NSPL-500. Please take the time to familiarize yourself with the system elements and their connections prior to attempting installation.

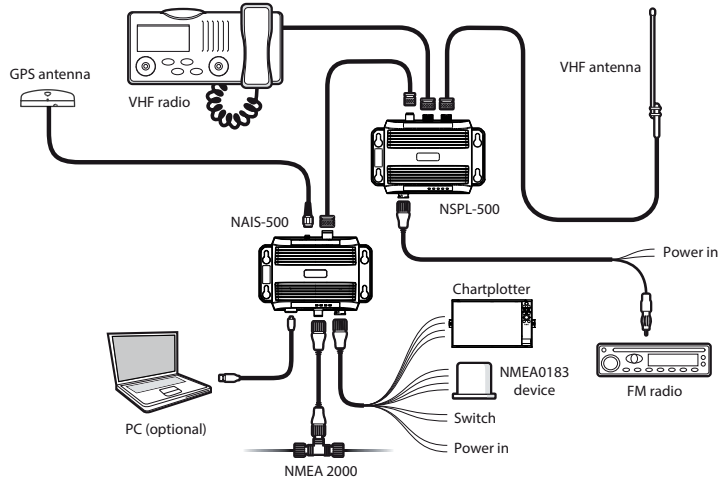

Figure 3 Typical installation configuration

In addition to the items provided with your NSPL-500 the following items will be required for installation:

VHF antenna

Connection to a suitable VHF antenna will be required for the NSPL-500 to operate. A standard marine band VHF antenna such as that used with VHF voice radios will be sufficient. Please take note of the warnings in section 1 regarding the use of antennas.

VHF radio

If you have an existing VHF voice radio connected directly to a VHF antenna, you can disconnect the VHF radio from the VHF antenna and connect them both to the relevant connectors on the NSPL-500.

AIS transceiver

If you have an existing AIS transceiver connected directly to a VHF antenna, you can disconnect the AIS transceiver from the VHF antenna and connect them both to the relevant connectors on the NSPL-500.

It is necessary to connect the VHF antenna, VHF radio and AIS transceiver for the antenna splitter to function correctly.

FM radio

The NSPL-500 also provides connections for the antenna of an FM broadcast radio receiver. Connection of an FM radio is optional.

Power cable

The NSPL-500 is supplied with a two meter long power cable. If you require longer cables to reach your power supply please ensure the cables are capable of carrying currents of up to 200 mA on average. Please contact your local qualified marine installer.

Installation procedures

Before beginning installation of your NSPL-500, please ensure you have the necessary additional items as detailed in the previous section **Preparing for installation**. It is strongly recommended that you read all of the instructions in this manual prior to installation.

If after reading this manual you are unsure about any element of the installation process, please contact your dealer for advice.

The following sections explain the installation process step by step for each of the main elements of the system.

Step 1 - Installing the NSPL-500

Please note the following guidelines when selecting a location for your NSPL-500:

- The NSPL-500 must be fitted in a location where it is at least 0.3 m from a compass or any magnetic device.
- There should be adequate space around the NSPL-500 for routing of cables. See Figure 4 for details of the NSPL-500 dimensions.
- The ambient temperature around the NSPL-500 should be maintained between -15°C and +55°C.
- The NSPL-500 should not be located in a flammable or hazardous atmosphere such as in an engine room or near to fuel tanks.

- The NSPL-500 is fully waterproof to ingress protection rating IP67, however it is recommended that the NSPL-500 is not subjected to extended periods of exposure to spray or submersion.
- It is acceptable to mount the NSPL-500 either vertically or horizontally.
- The VHF antenna splitter must be installed in a 'below decks' environment.
- The NSPL-500 should be mounted in a location where the indicators are readily visible as these provide important information on the status of the NSPL-500.

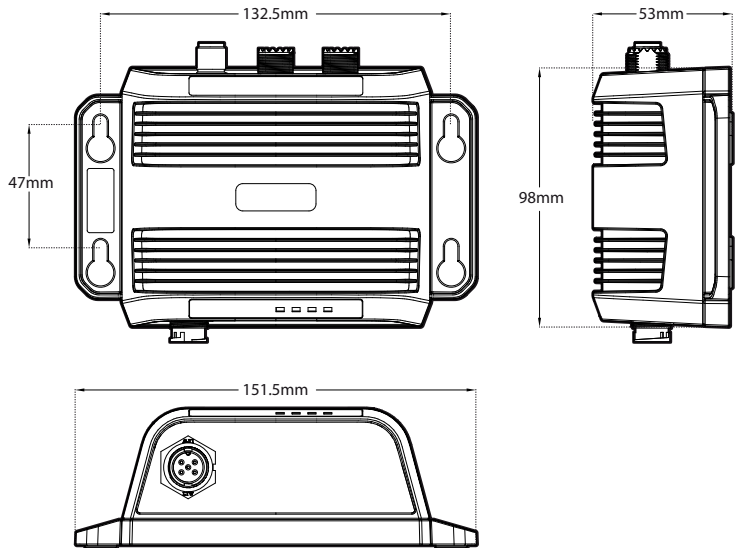

Figure 4 NSPL-500 dimensions

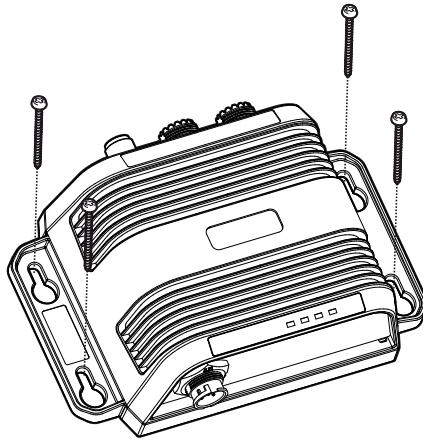

Figure 5 NSPL-500 mounting

Step 2 - Connecting the VHF antenna

Route the cable from the VHF antenna to the NSPL-500 and connect to the **VHF antenna connector** on the NSPL-500 as shown in Figure 6.

A standard marine band VHF antenna or AIS antenna should be used with the NSPL-500. The connector type on the NSPL-500 is SO239. Your chosen VHF antenna requires a PL259 connector to mate with this. If your VHF antenna does not use this type of connector please contact your dealer for details of available adaptors.

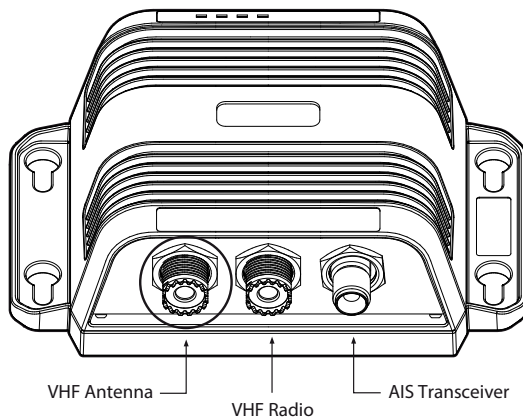

Figure 6 Position of the VHF antenna connector

Step 3 - Connecting the VHF radio

Using the VHF radio accessory cable provided with this product, route the cable from the VHF radio to the NSPL-500 and connect to the **VHF radio connector** on the NSPL-500 as shown in Figure 7. If the cable supplied is not long enough please contact your dealer for details of suitable extension cables.

A standard marine band VHF voice radio should be used with the NSPL-500. The antenna splitter is DSC compatible.

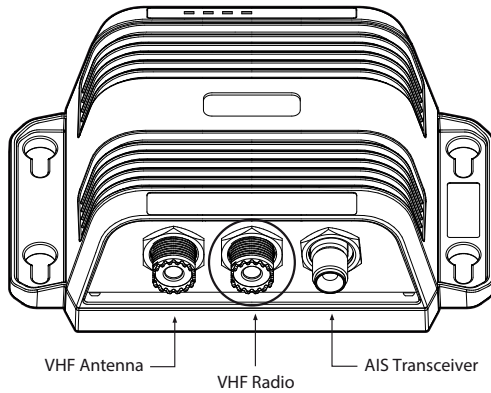

Figure 7 Position of the VHF radio connector

Step 4 - Connecting the AIS transceiver

Using the AIS transceiver accessory cable provided with this product, route the cable from the AIS transceiver to the NSPL-500 and connect to the **AIS transceiver connector** on the NSPL-500 as shown in Figure 8. If the cable supplied is not long enough please contact your dealer for details of suitable extension cables.

A fully approved marine AIS class B transceiver, such as the NAIS-500, or AIS receiver should be used with the NSPL-500 and requires a SO239 VHF antenna connector to connect to the NSPL-500 using the supplied accessory cable.

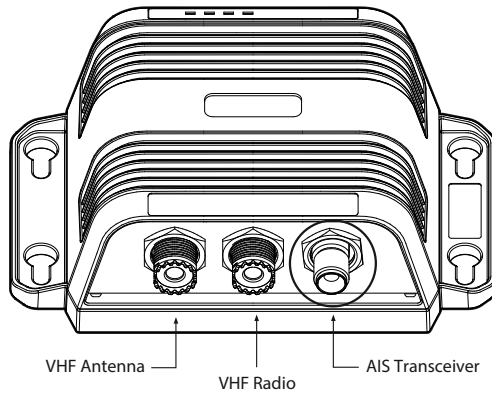

Figure 8 Position of the AIS transceiver connector

Step 5 - Connecting the power supply and optional FM output

The NSPL-500 requires a 12 V or 24 V power supply typically provided by the vessel's battery. It is recommended that crimped and soldered lugs are used to connect the NSPL-500 to the power source. It is recommended that the power supply is connected via a suitable circuit breaker and/or 1A fuse block.

1. Connect the red wire to the power supply positive terminal.
2. Connect the black wire to the supply negative terminal.
3. Connect the FM connector to the FM radio antenna input.

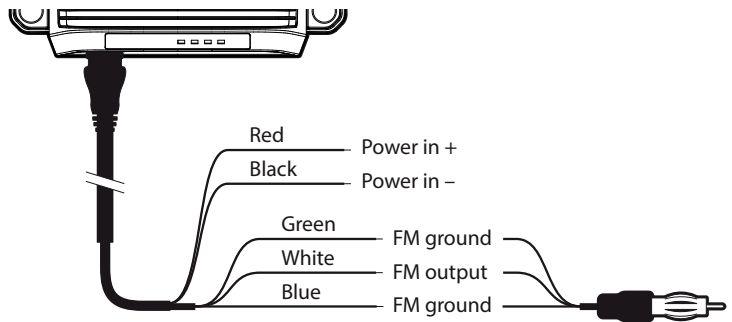

Figure 9 Connecting the power supply and optional FM output

- **Note:** If the FM connector is not used, please ensure the connector is set aside and insulated from making contact with any electrical sources. Alternatively, the connector can be cut away, but ensure the Green, White and Blue wires are separately insulated.

4

Operation

Operation of the NSPL-500 is automatic and requires no user intervention. During operation the antenna splitter will share signals received at your VHF antenna with both the AIS transceiver and the VHF radio.

When either the AIS transceiver or VHF radio transmits, the NSPL-500 will automatically sense the transmission and route the signal to the antenna.

If both a VHF radio and AIS transceiver are transmitting at the same time, the NSPL-500 will give priority to the VHF radio.

⚠ Warning: It is not possible for both connected devices to transmit simultaneously using a single VHF antenna. When talking on the VHF radio, AIS position reports are not transmitted.

Indicator functions

The NSPL-500 includes three colored indicators as shown in Figure 10. The state of the indicators provides information regarding the status of the NSPL-500.

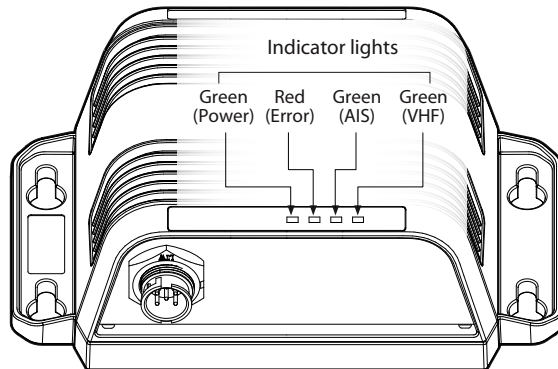

Figure 10 Indicator location on the NSPL-500 unit

The indicators provide the following functions:

- Power - this indicator is illuminated whilst the unit is powered
- Error - this indicator illuminates when antenna has short or open circuit generated by VHF transmission at 25 W
- TX AIS - this indicator flashes to indicate AIS transmissions
- TX VHF - this indicator flashes to indicate VHF radio transmissions

5

Troubleshooting

Issue	Possible cause and remedy
Power indicator not illuminated	Check power supply connections and fuse or circuit breaker
	Check polarity of power supply connections
	Check power supply voltage
'VHF' indicator does not illuminate when VHF Radiotelephone is transmitting	Check the antenna output of the VHF Radiotelephone is connected to the antenna splitter input labelled 'VHF'
'AIS' indicator does not illuminate when AIS transceiver is transmitting	Check the antenna output of the AIS transceiver is connected to the antenna splitter input labelled 'AIS'
Clicks or pops are heard from a connected FM broadcast receiver	This is normal and may occur during VHF or AIS transmission
VHF or AIS transmission range is reduced	A small reduction in transmission range is normal and due to the insertion loss of the antenna splitter
Both the 'AIS' and 'VHF' indicators illuminate when the VHF radio is transmitting	This is normal operation with some brands of VHF radio and not a fault. Function of the antenna splitter is unaffected

If the guidance given in the table above does not rectify the problem you are experiencing please contact your dealer for further assistance.

6

Specifications

Parameter	Value
Dimensions	152 x 98 x 52 mm (L x W x H)
Weight	260 g
Voltage supply	DC 9.6 to 31.2 V
Current consumption	<150 mA at 12 VDC
VHF and AIS frequency range	156 MHz to 162 MHz
Insertion loss AIS & VHF receive paths 0 dB	0 dB
Insertion loss AIS & VHF transmit paths	Typical 1 dB
Max input power, AIS port	12.5 W
Max input power, VHF port	25 W
Min input power, VHF port	0.5 W
AIS, VHF and Antenna port impedance	50 Ohms
FM port impedance	75 Ohms
Operating temperature	-15°C to +55°C
Ingress protection	IP67

NOTES:

NOTES:



LOWRANCE

SIMRAD

B&G

www.bandg.com
www.simrad-yachting.com
www.lowrance.com