



OPERATION MANUAL

SAIL-DRIVE

SD60

 English

YANMAR

**California
Proposition 65 Warning**

Diesel engine exhaust and some of its constituents are known to the state of California to cause cancer, birth defects, and other reproductive harm.

**California
Proposition 65 Warning**

Battery posts, terminals, and related accessories contain lead and lead compounds, chemicals known to the state of California to cause cancer and reproductive harm.
Wash hands after handling.

Disclaimers:

All information, illustrations and specifications in this manual are based on the latest information available at the time of publishing. The illustrations used in this manual are intended as representative reference views only. Moreover, because of our continuous product improvement policy, we may modify information, illustrations and/or specifications to explain and/or exemplify a product, service or maintenance improvement. We reserve the right to make any change at any time without notice. Yanmar and **YANMAR** are registered trademarks of YANMAR CO., LTD. in Japan, the United States and/or other countries.

All Rights Reserved:

No part of this publication may be reproduced or used in any form by any means - graphic, electronic, or mechanical, including photocopying, recording, taping, or information storage and retrieval systems - without the written permission of YANMAR CO., LTD.

Please review and comply with the applicable laws and regulations of the international export control regimes at the territory or country where the product and manual are intended to be imported and used.

| | | |
|------------------|-------|--------------|
| OPERATION MANUAL | MODEL | SD60 |
| | CODE | 0ASDM-EN0022 |

TABLE OF CONTENTS

| | Page |
|--|------|
| Introduction | 1 |
| Safety | 3 |
| Safety Precautions | 4 |
| General Information | 4 |
| Before You Operate..... | 4 |
| During Operation and Maintenance..... | 5 |
| Product Overview | 9 |
| Overview | 9 |
| Owner/Operator Responsibilities | 9 |
| New Sail-Drive Break-In: | 9 |
| Dealer/Distributor Responsibilities..... | 9 |
| Galvanic Corrosion..... | 10 |
| Corrosion Control | 10 |
| Electrical Connections and Regulations According to International Rules ISO 60092-507 IEC:2008 | 11 |
| Shore Power | 11 |
| Painting the Boat..... | 12 |
| Check Under-Water Metallic Parts | 12 |
| Gear Identification | 13 |
| Before You Operate | 15 |
| Lubricating Oil | 16 |

TABLE OF CONTENTS

| | |
|--|----|
| Sail-Drive Operation | 17 |
| Operation..... | 18 |
| Boat Sailing, Moving in Tow or Anchoring | 18 |
| Direction of Rotation..... | 19 |
| Gear Shift Operation | 20 |
| Periodic Maintenance | 21 |
| Maintenance | 22 |
| Routine Maintenance | 22 |
| Scheduled Maintenance..... | 22 |
| Maintenance Procedures..... | 23 |
| Oil Level Check | 23 |
| Oil Change | 24 |
| Removing Propeller..... | 27 |
| Installing Propeller..... | 28 |
| Corrosion Protection | 30 |
| Anode Replacement..... | 31 |
| Electric Installation | 33 |
| Troubleshooting | 35 |
| Specifications | 37 |

INTRODUCTION

This *Operation Manual* describes Sail-Drive Models SD60. For engine handling and operation, refer to the respective *Operation Manuals* for Engine Models JH series in the below table. However, instructions for the marine gear box are not necessary as they are included.

| Engine Model | Sail Drive Model |
|--------------|------------------|
| 3JH5E | SD60-5 |
| 3JH5AE | |
| 4JH5E | |
| 3JH40 | |
| 4JH45 | |
| 4JH57 | |
| 4JH4-TE | SD60-4 |
| 4JH80 | |

This Page Intentionally Left Blank

SAFETY

Yanmar considers safety of great importance and recommends that anyone that comes into close contact with its products, such as those who install, operate, maintain or service Yanmar products, exercise care, common sense and comply with the safety information in this manual.



This safety alert symbol appears with most safety statements. It means attention, become alert, your safety is involved! Please read and abide by the message that follows the safety alert symbol.

DANGER

Indicates a hazardous situation which, if not avoided, *will* result in death or serious injury.

WARNING

Indicates a hazardous situation which, if not avoided, *could* result in death or serious injury.

CAUTION

Indicates a hazardous situation which, if not avoided, *could* result in minor or moderate injury.

NOTICE

Indicates a situation which can cause damage to the Sail-Drive, personal property and/or the environment or cause the equipment to operate improperly.

SAFETY PRECAUTIONS

General Information

There is no substitute for common sense and careful practices. Improper practices or carelessness can cause burns, cuts, mutilation, asphyxiation, other bodily injury or death. This information contains general safety precautions and guidelines that must be followed to reduce risk to personal safety. Special safety precautions are listed in specific procedures. Read and understand all of the safety precautions before operation or performing repairs or maintenance.

Before You Operate

DANGER



- **Never permit anyone to install or operate the Sail-Drive without proper training.**
- **Read and understand this *Operation Manual* before you operate or service the Sail-Drive to ensure that you follow safe operating practices and maintenance procedures.**
- **Safety signs and labels are additional reminders for safe operating and maintenance techniques.**
- **See your authorized Yanmar marine dealer or distributor for additional training.**

Crush Hazard



- **Never stand under a hoisted Sail-Drive.**
- **If the hoist mechanism fails, the Sail-Drive will fall on you. When you need to transport a Sail-Drive for repair, have a helper assist you to attach it to a hoist and load it onto a truck.**
- **Never support marine gear with equipment not designed to support the weight of the marine gear such as wood blocks or by only using a jack.**
- **Never use the Sail-Drive lifting eye to lift the engine and Sail-Drive as an assembly. Use the engine lifting eyes to lift the engine and Sail-Drive. Only use the Sail-Drive lifting eye to lift the Sail-Drive as a separate component.**

During Operation and Maintenance

DANGER

Explosion Hazard



While the engine is running or the battery is charging, hydrogen gas is being produced and can be easily ignited. Keep the area around the battery well-ventilated and keep sparks, open flame and any other form of ignition out of the area.

Fire Hazard



Ensure that appropriate fire detection and extinguishing equipment are installed and checked periodically for proper operation.

WARNING

Fire Hazard

Undersized wiring systems can cause an electrical fire.



Sever Hazard



- Never service the Sail-Drive while under tow or if the engine is running at idle speed. The propeller may rotate under these circumstances.
- Never wear jewelry, unbuttoned cuffs, ties or loose fitting clothing and always tie long hair back when working near moving/rotating parts. Keep hands, feet and tools away from all moving parts.
- Always remove any tools or shop rags used during maintenance from the area before operation.
- Never service the Sail-Drive while under tow or if the engine is running at idle speed. The propeller may rotate under these circumstances.
- Always stop the engine before you begin to service the Sail-Drive and secure the propeller so it will not turn.

Alcohol and Drug Hazard



Never operate the engine while under the influence of alcohol or drugs or when feeling ill.

WARNING

Exposure Hazard



Always wear personal protective equipment including appropriate clothing, gloves, work shoes, eye and hearing protection as required by the task at hand.

Entanglement Hazard



- Never leave the key in the key switch when you are servicing the Sail-Drive. Someone may accidentally start the engine and not realize you are servicing it.
- Never operate the engine while wearing a headset to listen to music or radio because it will be difficult to hear the warning signals.

Burn Hazard



Some of the engine and Sail-Drive surfaces become very hot during operation and shortly after shut-down. Keep hands and other body parts away from hot surfaces.

Sudden Movement Hazard

Always stop the engine before beginning service.

WARNING

Exhaust Hazard



- Never block windows, vents, or other means of ventilation if the engine is operating in an enclosed area.
- All internal combustion engines create carbon monoxide gas during operation and special precautions are required to avoid carbon monoxide poisoning.
- To prevent accidental equipment movement, never start the engine in gear.
- Before starting the engine, always make sure that all bystanders are clear of the area. Keep children and pets away while the engine is operating.
- Avoid unexpected equipment movement. Shift the Sail-Drive into the NEUTRAL position any time the engine is at idle.

Electrical Shock Hazard



- Always turn off the battery switch (if equipped) or disconnect the negative battery cable before servicing the Sail-Drive.
- Always keep the electrical connectors and terminals clean. Check the electrical harnesses for cracks, abrasions, and damaged or corroded connectors.

CAUTION**Poor Lighting Hazard**

Ensure that the work area is adequately illuminated. Always install wire cages on portable safety lamps.

Tool Hazard

Always use tools appropriate for the task at hand and use the correct size tool for loosening or tightening machine parts.

Exposure Hazard

Always wear eye protection when servicing the Sail-Drive or when using compressed air or high-pressure water. Dust, flying debris, compressed air, pressurized water or steam may injure your eyes.

Slipping and Tripping Hazard

Ensure that adequate floor space is set aside for servicing Sail-Drive. The floor space must be clean, flat and free of spilled liquids and debris to prevent slipping or tripping.

NOTICE

It is important to perform daily checks as listed in this *Operation Manual*.

Periodic maintenance prevents unexpected downtime, reduces the number of accidents due to poor Sail-Drive performance and can help extend the life of the Sail-Drive and engine.



Always be environmentally responsible.

Follow the guidelines of the EPA or other governmental agencies for the proper disposal of hazardous materials such as lubrication oil, diesel fuel and engine coolant. Consult the local authorities or reclamation facility.

Never dispose of hazardous materials by dumping them into a sewer, on the ground or into ground water or waterways.

Never attempt to modify the Sail-Drive's design or safety features.

- Never release or modify the limiting devices such as the engine speed limit, fuel injection limit, etc.
- Modification will impair the safety and performance of the product and shorten product life.
- Modifications to the design, safety or limiting features will void the warranty.

NOTICE

If the Sail-Drive oil temperature is too high, stop engine immediately and check the Sail-Drive oil level.

The anode of the Sail-Drive is only calculated for the Sail-Drive. Using the different material propeller may require additional anodes to be installed on the propeller itself.

Failure to use the correct anode material may result in inadequate protection and excessive corrosion of underwater drive system components. Use only zinc or aluminum anodes in brackish and saltwater applications. In freshwater applications, use aluminum or magnesium anodes for best results. Never use magnesium anodes in brackish or salt water, as they will deteriorate rapidly, which will lead to severe damage to the drive system.

Always tighten components to the specified torque. Loose parts can cause equipment damage or cause it to operate improperly.

Only use replacement parts specified. Other replacement parts may affect warranty coverage.

Never attempt to modify the Sail-Drive's design or safety features. Failure to comply may impair the marine gear's safety and performance characteristics and shorten the Sail-Drive's life. Any alterations to this Sail-Drive may affect the warranty coverage of your Sail-Drive.

PRODUCT OVERVIEW

OVERVIEW

Owner/Operator Responsibilities

The operator must, and assumes all responsibility to:

- Read and understand the *Operation Manual* prior to operating the Sail-Drive;
- Perform all safety checks as necessary to ensure safe operation;
- Comply with and follow all lubrication and maintenance instructions and recommendations; and
- Have an authorized Yanmar dealer/distributor perform periodic checkups.

Conducting normal maintenance service and replacing consumable parts as necessary is the responsibility of the owner/operator and necessary to provide the best durability, performance and dependability of the Sail-Drive while keeping your overall operating expenses to a minimum. Individual operating habits and usage may increase the frequency of performing maintenance service condition. Monitor conditions frequently to determine if the maintenance intervals suggested in the manual are frequent enough for your Sail-Drive.

New Sail-Drive Break-In:

- On the initial engine start-up, allow the engine to idle for approximately 15 minutes while you check for proper Sail-Drive function and Sail-Drive oil leaks.
- During the break-in period, carefully observe Sail-Drive seal indicators for proper Sail-Drive function.
- During the break-in period, check the Sail-Drive oil levels frequently.

Dealer/Distributor Responsibilities

In general, a dealer's responsibilities to the customer include predelivery inspection and preparation such as:

- Ensure that the vessel is properly equipped.
- Prior to delivery, make certain that the Yanmar Sail-Drive and other equipment are in proper operating condition.
- Make all necessary adjustments for maximum efficiency.
- Familiarize the customer with the on-board equipment.
- Explain and demonstrate the operation of the Sail-Drive and vessel.

GALVANIC CORROSION

Galvanic corrosion results whenever two or more dissimilar metals (like those found on the sail-drive) are submerged in a conductive solution, such as saltwater, polluted water or water with a high mineral content because a chemical reaction takes place causing electrical current to flow between the metals. The electrical current flow causes the metal that is most chemically active, or anodic, to erode. If not controlled, galvanic corrosion may corrode Sail-Drive components.

CORROSION CONTROL

It is the boat designer's responsibility and/or the re-powering engineer's responsibility to design the proper systems and equipment to control and reduce the possibility of galvanic corrosion.

However, it is essential that the owner/operator frequently monitor the anodes for wear, inspect the sail-drive for corrosion and replace the anodes often enough to provide a sacrificial surface for the electrical current to attack. Galvanic isolators and isolation transformers are also available from the aftermarket (not supplied by Yanmar). The Galvanic isolator is a device that is installed in series with the (AC) grounding (GREEN) conductor of the shore-power cable to effectively block low-voltage DC galvanic current flow but permit the passage of alternating current (AC)*.

The rate of corrosion depends on numerous factors, such as:

- the number, size and location of sacrificial anodes on the sail-drive and vessel;
- the marina environment, such as stray current in the water, fresh or salt water and use and isolation of shore power;
- improper application of marine paint or antifouling paint;
- failure to repaint damaged areas; and
- how the vessel is bonded.

Please check with the boat builder, dealer or other professional to determine if your vessel and/or Sail-Drive is adequately protected from galvanic corrosion.

* "The Boatowner's Guide to Corrosion", by Everett Collier.

NOTICE

The anode of the Sail-Drive is only calculated for the Sail-Drive. Changing the material of the propeller may require additional anodes to be installed on the Sail-Drive.

NOTICE

Failure to use the correct anode material may result in inadequate protection and excessive corrosion of underwater drive system components. Use only aluminum anodes in brackish and saltwater applications. In freshwater applications, use aluminum or magnesium anodes for best results. Never use magnesium anodes in brackish or salt water, as they will deteriorate rapidly, which will lead to severe damage to the drive system.

If sacrificial anodes erode quickly or if signs of corrosion are evident, the owner should take immediate corrective action. Yanmar recommends consulting an engineer specializing in marine electricity and corrosion control to determine the best way to correct the rapid erosion of the anodes.

Electrical Connections and Regulations According to International Rules ISO 60092-507 IEC:2008

It is recommended to perform the boat electric system in conformity with the regulation ISO 60092-507 IEC 2008, or equal local and international rules or laws.

To protect the boat from galvanic current when it is connected to the power source located on the dry land (wharf), it is recommended to install on the boat a galvanic isolator on the ground conductor of the AC power line.

This will prevent the flow of galvanic current with low voltage but will allow a normal supply.

For more information about or to find different solutions of the power system from the dry land, refer to the instructions of ABYC (American Boat and Yacht Council) in chapter E-11 or ISO 60092-507 IEC 2008.

At the same purpose can also be used an isolating transformer with the relevant characteristics of the circuit. Even in this case, refer to the applicable ABYC E-11 or ISO 60092-507 IEC 2008 for more information and suggestions.

Note: We advise you to install an isolating transformer for the electrical power supply from pier.

SHORE POWER

Vessels that are connected to shore power require additional protection to prevent destructive low voltage galvanic currents from passing through the shore power ground wire. Galvanic isolators are available from the aftermarket (not supplied by Yanmar) to block these currents while still providing a path to ground for dangerous shock currents.

NOTICE

If the AC shore power ground is not isolated from the boat ground, sacrificial anodes may be unable to neutralize the increased galvanic potential. Corrosion damage that results from the improper system design or application is not covered by the Yanmar Limited Warranty.

PAINTING THE BOAT

When painting the boat hull with anti-fouling paint, observe the following rules:

- Use high-quality, anti-fouling paint designed for marine use.
- Avoid using anti-fouling paint that contains copper material, which could conduct electrical current.
- Avoid using anti-fouling paint that contains copper material on the sail-drive foot in any case.
- If using copper-based or tin-based paints is necessary, ensure that they comply with all local and federal laws prohibiting their use.
- Do not paint drain holes or items as specified by the boat manufacturer.
- Do not paint any anodes.

CHECK UNDER-WATER METALLIC PARTS

Check the status of corrosion protection (boat dry) of the lower part of the hull before that the boat enters in the water.

Make sure all metallic parts over-hanging from the hull underneath the seawater line have to have the same potential.

Contact your local Yanmar dealer for advice.

This way will assure:

- All metallic parts will have same potential and will avoid having current/tension circulation when the boat is in the water. This create corrosion.
- All metallic parts are properly connected to the ground of the boat and they are, therefore, having the same potential.

GEAR IDENTIFICATION

Name Plate:

The name plate is fixed onto the sail drive

| | |
|-------------------------|--------------------------------|
| MODEL | <input type="text" value="A"/> |
| GEAR RATIO | <input type="text" value="B"/> |
| MFG.NO. | <input type="text" value="C"/> |
| P/N | <input type="text" value="D"/> |
| OIL TYPE | <input type="text" value="E"/> |
| YANMAR | |
| YANMAR CO., LTD. | |
| MADE IN EU | |

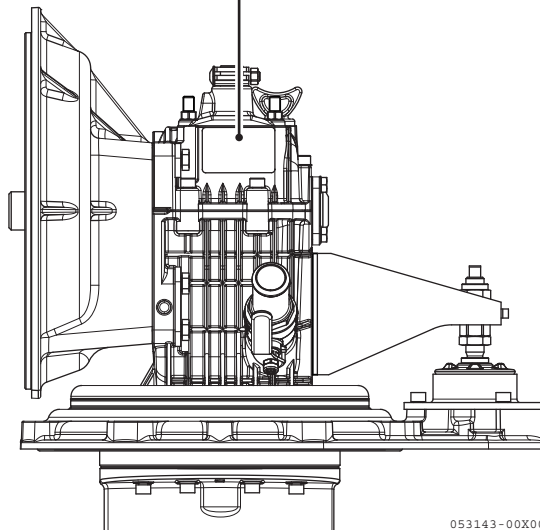

A – Sail drive type

B – Sail drive ratio

C – Sail drive serial number

D – Sail drive part number

E – Lubricating oil specifications

Figure 1

This Page Intentionally Left Blank

BEFORE YOU OPERATE

This section of the *Operation Manual* describes lubricating oil specifications and how to replenish them.

Before you operate the Sail-Drive, review the *Safety* section on page 3.

LUBRICATING OIL

The selection of lubricating oil is very important. If an inappropriate oil is used, or an oil change is neglected, it may result in damage and reduce the life of the Sail-Drive. When selecting a lubricating oil, use one of the following:

1. Lubricating oil type: API Service Categories CD or higher, SAE Viscosity 15W-40
2. Lubricating oil quantity: **Figure 1**

| | Quantity (ℓ) |
|--------------------|--------------|
| Standard (S) | 2.8 |
| with extension (L) | 3 |

3. Loosen dipstick (1, **Figure 1**) by turning the grip counterclockwise.
4. Wipe dipstick with a clean and dustfree cloth.
5. Insert dipstick do not screw. Remove dipstick and check lubricating oil level: Lubricating oil level has to be between minimum and maximum marks on the dipstick.
6. Check O-ring (2, **Figure 1**) for damage, replace if necessary.
7. Insert the dipstick and lock it by turning the grip clockwise.

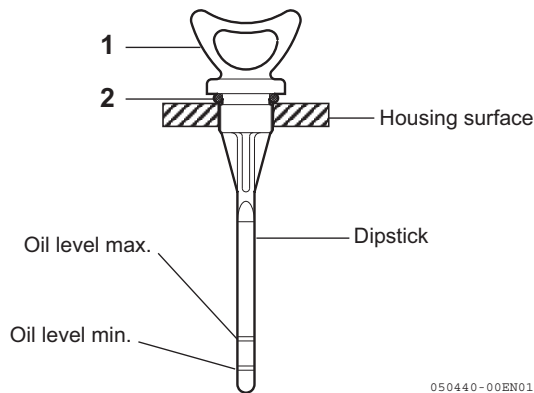

1 – Dipstick

2 – O-ring

Figure 1

SAIL-DRIVE OPERATION

Before you operate the Sail-Drive, read the following safety information and review the *Safety* section on page 3.

OPERATION

All SD60 have been submitted to a test run before shipment. During normal operation, the sail drive should only be shifted with the engine at idle speed. In emergency cases it is also admissible to shift at higher speeds. Visual checks for leakage should be made from time to time.

WARNING

Work on the sail drive must only be performed with the engine and propeller at stop.

CAUTION

- Before the first startup, the sail drive must be filled with oil. Start the engine only when the sail drive is in neutral position.
 - Using the sail drive with an insufficient oil level will damage the gears. An excessive oil level may cause leakage at the shaft seals and the sail drive breather, and raise the operating temperature considerably.
-

Boat Sailing, Moving in Tow or Anchoring

When the engine is off, and the boat sails, moves in tow or is anchored, the propeller may turn with the water current.

WARNING

- Do not work on the sail drive when being towed, or anchoring in a river because the propeller may rotate.
- When the engine runs idle, but the propeller shaft should not be driven (such as when charging the battery with the generator), the shifting lever (Figure 1) must be held in the neutral position (N) to prevent the boat from moving.

CAUTION

When the boat sails with engine is off, the shift position of the sail drive can be:

- In neutral position and in this case the propeller is free to rotate.
- In reverse position:
 - To lock the fixed propeller.
 - To fold the folding propeller.
 - To feather the feathering propeller.

CAUTION

Do not put the shifting lever of the sail drive in forward position, otherwise the sail drive could be damaged!

Direction of Rotation

- Shifting to “A”
= Propeller rotation; Same direction as engine crankshaft
- Shifting to “B”
= Propeller rotation; Opposite direction from the engine crankshaft

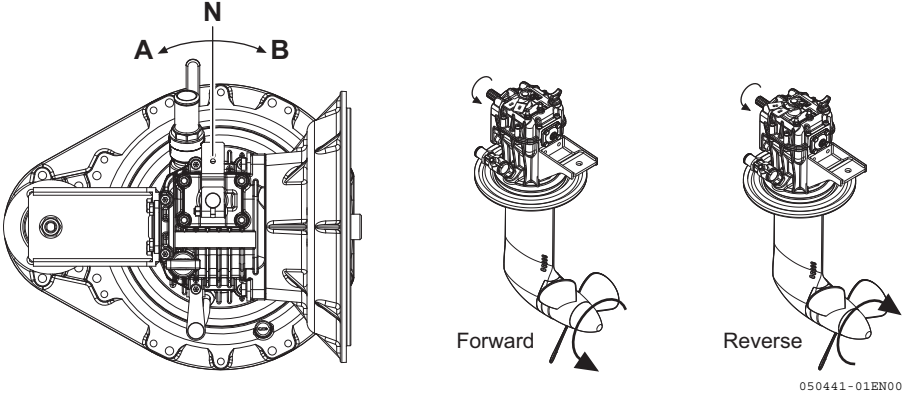

Figure 1

SAIL-DRIVE OPERATION

Gear Shift Operation

CAUTION

Make certain that control rod or cable is easily movable.

1. Lever travel:

Minimum travel of gear shift lever (O - A = O - B) must be 35 mm (1.3/8 in.) for outer pivot point and 30 mm (1.3/16 in.) for inner pivot point.

2. Lever position: In neutral position perpendicular to control rod or cable. Gear shift lever can be fixed in any position by means of clamping screw. Minimum distance between gear shift lever and cover 0.5 mm (0.02 in.). Opening or loosening of cover requires renewed adjustment (by specialized personnel only).
3. Regular checks are required to ensure the strict observance of item 1 and 2 above.

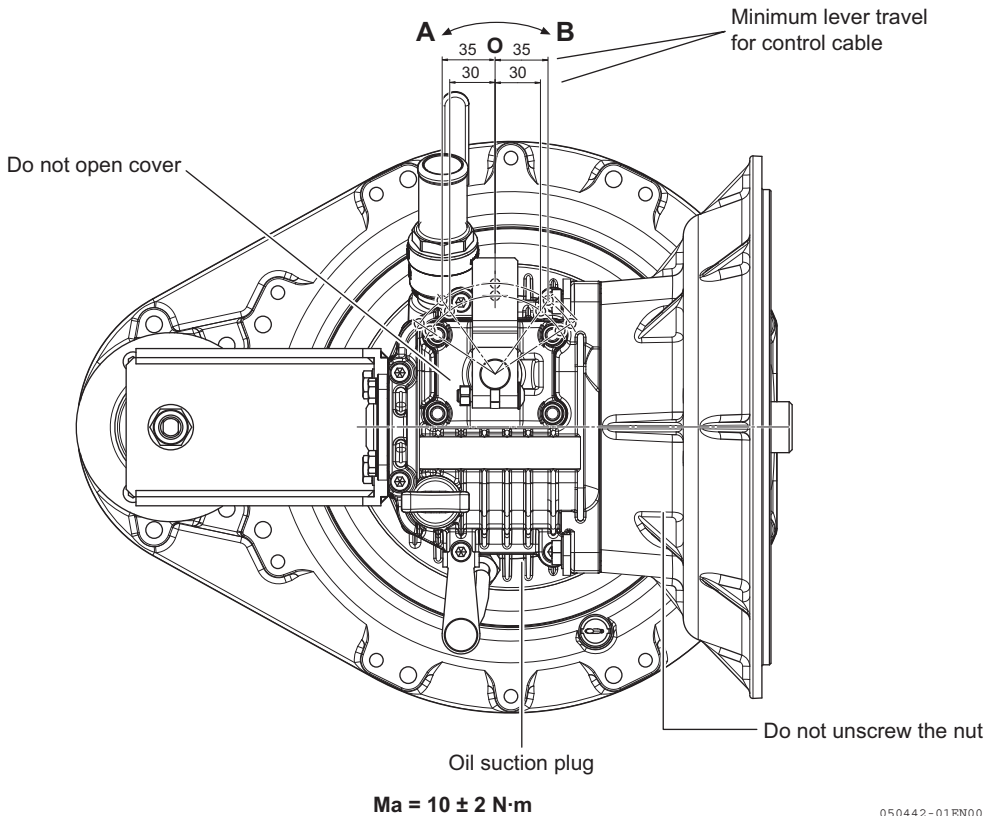

Figure 2

PERIODIC MAINTENANCE

Before you perform maintenance on the Sail-Drive, read the following safety information and review the *Safety* section on page 3.

This section of the *Operation Manual* describes the procedures for proper care and maintenance of the Sail-Drive.

PERIODIC MAINTENANCE

MAINTENANCE

Maintenance programs described below are valid for the SD60, not the engine. For the intervals and procedures for maintenance of the engine, refer to the operation manual and maintenance of the engine.

Routine Maintenance

| Maintenance Schedule | Maintenance to be Performed |
|-------------------------------|---|
| At the beginning of the day | Check the sail drive oil level. |
| Every two months of operation | Check the battery connections and acid level. |
| | Ensure that the clamps and the wiring connections are secure. Clean the clamps (every two operating months or every 50 hours, according to the interval that occurs first. In case of use in saltwater, the interval is reduced to every 25 hours or 30 days of operation, according to the interval that occurs first). |

Scheduled Maintenance

| Interval | Maintenance to be Performed |
|---|---|
| After the first 50 hours | Change the oil. |
| Every 250 hours of operation or once a year, according to the interval that occurs first. | Change the oil. |
| | Lubricate and check that the sea chest opens and closes freely. |
| Every 500 hours or once a year, according to the interval that occurs first. | Lubricate the propeller shaft splines and tighten the propeller nuts. |
| | Check that pipe fitting are properly tight. |
| | Check that in the grounding circuit (continuity) are not loose or damaged connections. |
| | Ensure that the electrical system fasteners are not loose, damaged or corroded. Make sure that there are not any loose, damaged or corroded wires and connectors. |
| | Check that the hose clamps on flexible pipes are properly tight. |
| Apply an antifouling without copper material. | |
| Replace every 7 years | Replace the foot sealing membrane. |

MAINTENANCE PROCEDURES

Oil Level Check

1. Check the oil level by removing the dipstick.
Wipe the dipstick with a clean, lint-free cloth.

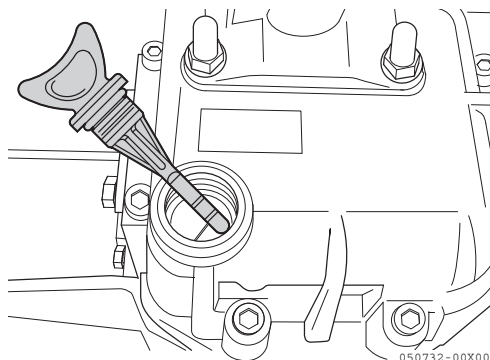

Figure 1

2. Insert the dipstick so that it rests on top of the threads into the case.
Remove the dipstick and check the lubricating oil level on the dipstick. The lubricating oil level must be between the marks of minimum and maximum on the dipstick. Add oil as necessary.

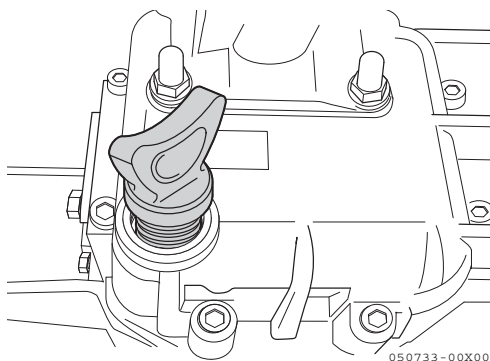
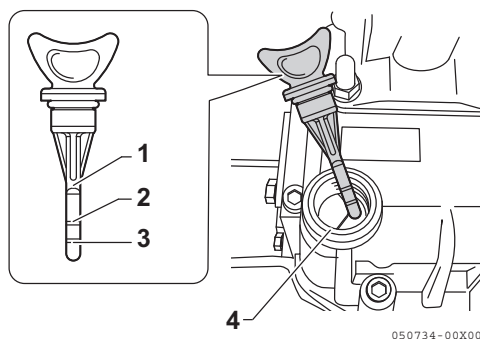

Figure 2



- 1 – Dipstick
- 2 – Maximum
- 3 – Minimum
- 4 – Upper edge of threaded hole

Figure 3

PERIODIC MAINTENANCE

Oil Change

Oil change procedure/Drain from lower plug of sail drive

1. Un-screw the oil dipstick.

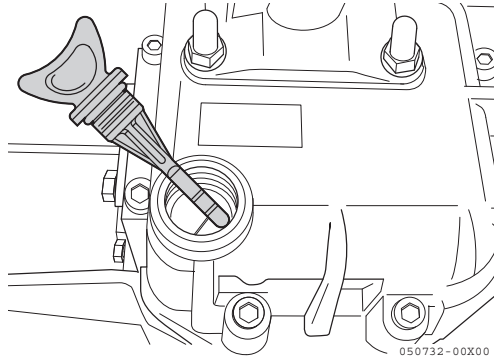

Figure 4

2. Prepare a suitable container to collect the lubricating oil. Remove the lower plug and drain the oil. Dispose of used oil properly.

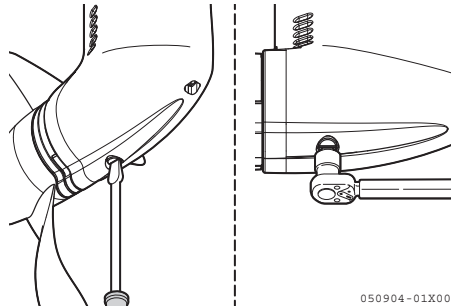

Figure 5

3. Connect a hand oil pump onto the fitting of the oil drain hole in the SD60 drive. Be careful not to damage the thread of the drain hole.

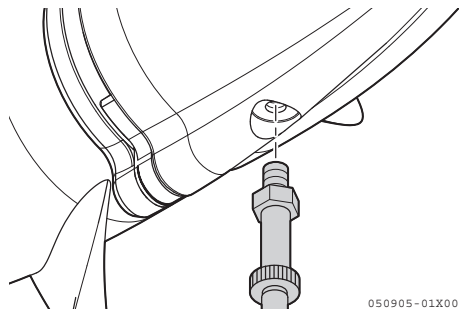

Figure 6

- Using low pressure pump, add oil.
3L-SAE 15W-40

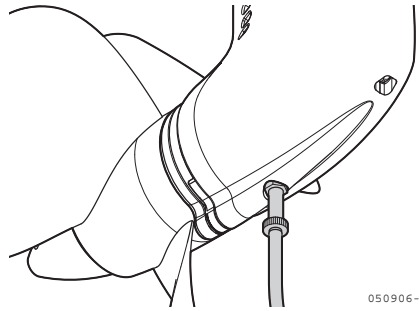

Figure 7

- Replace the O-rings on the oil cap sail drive, lubricate it and prepare to reassemble it.

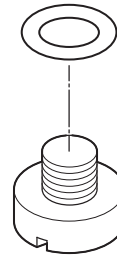

Figure 8

- Screw in the oil dipstick and tighten by hand.

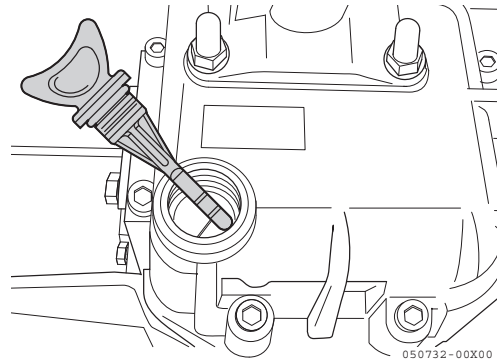

Figure 9

PERIODIC MAINTENANCE

- Remove the oil pump fitting and quickly install the oil plug. Torque 10 N·m.
Add oil at the dipstick hole to reach the proper level as indicated on the dipstick.

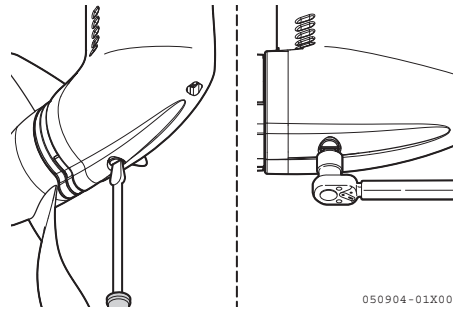

Figure 10

Oil change procedure from engine room for easy maintenance/Suction of sail drive fluid

- Oil change must be done removing the plug (1, **Figure 11**) from the oil suction pipe (2, **Figure 11**).
Suction can be done with hand pump (4, **Figure 12**).
- Push hose of hand pump (4, **Figure 12**) through the suction pipe (2, **Figure 11**) and suck the fluid off.
- Un-screw the oil dipstick (3, **Figure 11**).
- Add oil. 3L-SAE 15W-40
- Screw in the oil dipstick (3, **Figure 11**).

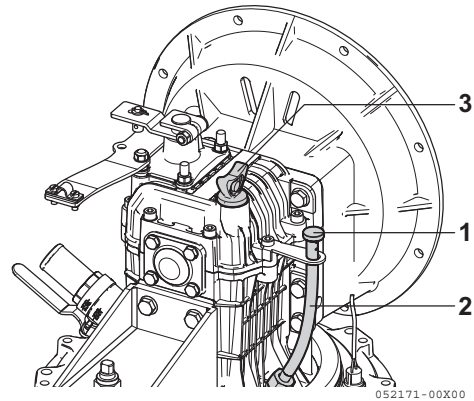

Figure 11

NOTICE

The used oil is to be handled as special waste that pollute the environment. For the safe disposal of used oil, take all the measures required by the relevant local rules and legislations.

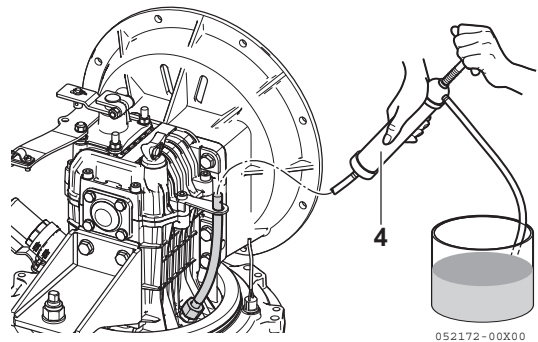
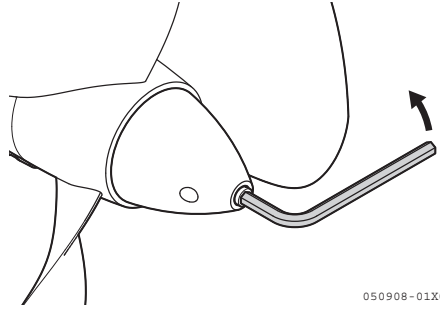

Figure 12

Removing Propeller

1. Place a block of wood between the propeller blade and the hull.
Using a 6 mm allen wrench, loosen and remove the locking screw of the bullet.



050908-01X00

Figure 13

2. Insert a suitable tool into the hole.
Loosen and remove the propeller spinner nut.

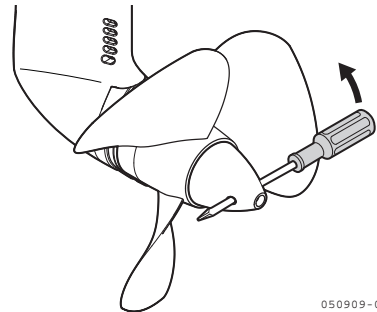

050909-01X00

Figure 14

3. Remove the wooden block.
Remove the propeller.
If necessary, use a plastic hammer and gently tap to remove.

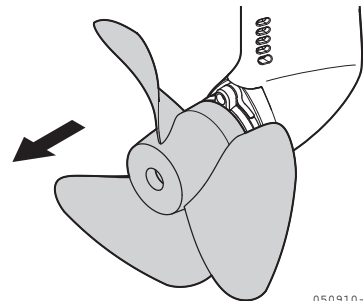

050910-01X00

Figure 15

PERIODIC MAINTENANCE

4. Remove the propeller sleeve.

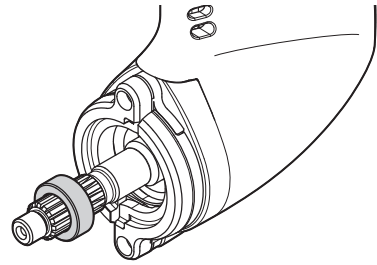

050911-01X00

Figure 16

Installing Propeller

1. Assemble the propeller shaft thrust bearing sleeve. Install chamfered side away from propeller.

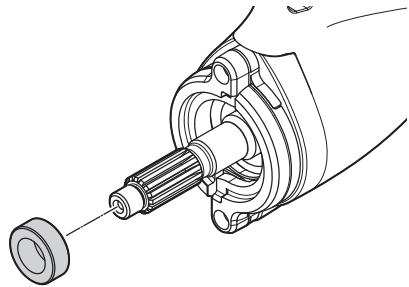

050912-01X00

Figure 17

2. Put some anti-corrosion grease on the grooves of the propeller shaft.

| Description | Employment |
|------------------------------|-------------------------|
| Antifouling grease | Propeller shaft splines |
| Special lubricant | Propeller shaft splines |
| Marine lubricant with teflon | Propeller shaft splines |

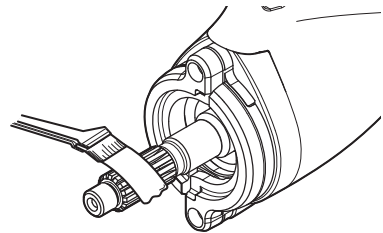

050912-01X00

Figure 18

- Align the splines and insert the propeller on the propeller shaft. The propeller shaft must fit evenly on the splines.

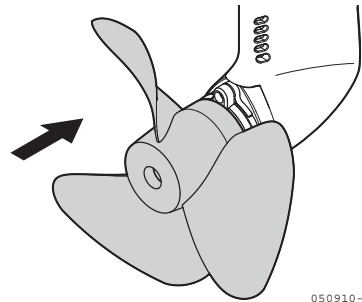

050910-01X01

Figure 19

- Wipe off excess grease. Install the propeller shaft nut.

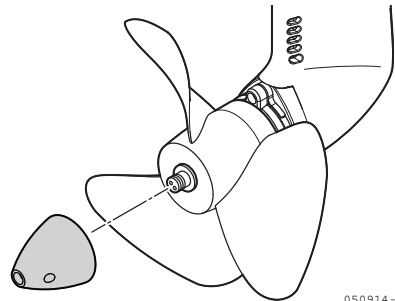

050914-01X00

Figure 20

- Place a block of wood between one of the propeller blades and the hull. Mount the special insert T2 on a suitable torque wrench and insert into the hole in the propeller nut and tighten to a torque of 125 N·m.

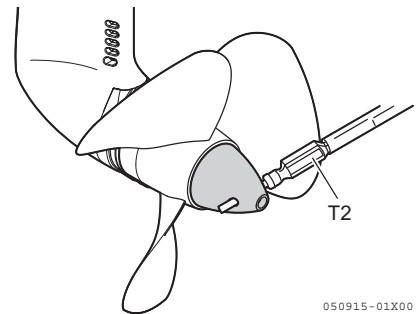

050915-01X00

Figure 21

- Install the locking screw in the center. Tighten the locking screw to a torque of 23 N·m.

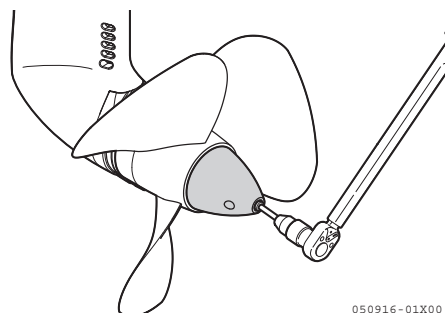

050916-01X00

Figure 22

Corrosion Protection

The SD60 is equipped with a replaceable sacrificial anode on the lower leg of the drive. This anode is designed to dissolve in response to electrical current generated while in sea water.

This anode is not designed to accommodate other hardware or other excessive electrical currents related to additional components or changes to the electrical AC and DC systems on board the vessel.

This replaceable sacrificial anode capacity is for the drive only. When a non-Aluminium propeller is installed, the non-Aluminium propeller must have a additional replaceable sacrificial anode.

The SD60 will be mechanically connected to the powering engine. The design of the electrical system of the engine will impact the selection of a proper galvanic protection system.

■ Isolated systems

If the engine alternator and starting motor uses an isolated circuit (having both a battery + and – connection terminal) then the system can be treated as an “isolated” system.

■ Non-Isolated systems

If either the starter motor or the alternator uses a single battery + and uses the body or case as a ground through the engine, then the system of the SD60 and the engine must be considered as “grounded” to the battery negative and not isolated.

■ Suggested actions

For information on this topic, review the published guidelines as contained in ABYC guidebook, section E-2.

Upon final delivery of the vessel a review of the electrical bonding system should be conducted. An expert in the field of electrical bonding should be called upon to review the completed vessel. This review should determine if there is an appropriate amount or sizing of sacrificial anodes installed in order to protect the mechanical components (engine and SD60) from damage from galvanic corrosion.

Please keep in mind, changes made to the vessels AC and DC systems may impact the protection of the installed anode system.

Damage to the SD60 as a result of failure to maintain a good balanced galvanic protection system is not the responsibility of Yanmar.

Anode Replacement

To minimize galvanic corrosion, the SD60 system has a sacrificial anode placed on the foot of the sail drive.

This anode is not designed to accommodate other hardware or other excessive electrical currents related to additional components or changes to the electrical AC and DC systems on board the vessel.

This replaceable sacrificial anode capacity is for the drive only.

When a non-Aluminium propeller is installed, the non-Aluminium propeller must have a additional replaceable sacrificial anode.

The anodes provide protection against corrosion under normal use.

1. Using a 6 mm “Allen” key, remove the M8 screws of the anode.

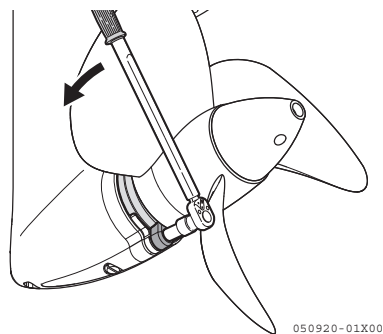

Figure 23

2. Remove the anode of the foot.
If necessary, remove using a plastic mallet. The anode is two piece type.
3. Place the new two piece anode on the foot.

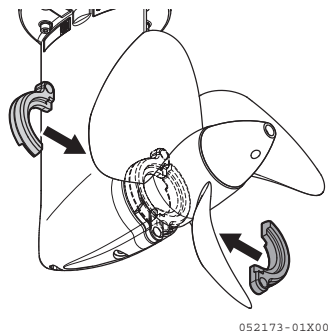
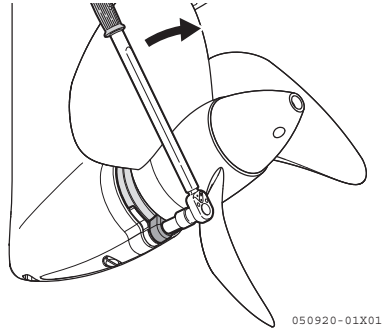

Figure 24

PERIODIC MAINTENANCE

4. Tighten to a torque of 12 N·m.



050920-01X01

Figure 25

ELECTRIC INSTALLATION

Verify carefully the correct engine grounding.

NOTICE

Grounding is normally connected to the negative pole of the battery.
An incorrect installation can cause a premature corrosion of the SD60 lower gear assembly.

This Page Intentionally Left Blank

TROUBLESHOOTING

Before performing any troubleshooting procedures within this section, review the *Safety* section on page 3.

If a problem occurs, stop the engine immediately. Refer to the Symptom column in the Troubleshooting Chart to identify the problem.

TROUBLESHOOTING

First of all check, whether all items of operating instructions have been complied with. The following assists you in troubleshooting.

| Symptom | Possibly caused by | Remedy |
|------------------------------|---|--|
| 1. High oil temperature | <ul style="list-style-type: none"> • Oil level high during operation • Oil level low • No water in cooling system • Unknown | <ul style="list-style-type: none"> • Pump out oil to max. mark on dipstick • Add oil • Check cooling system and repair • Consult authorized Yanmar marine distributor or dealer |
| 2. Oil on sail drive housing | <ul style="list-style-type: none"> • Loose screws • Loose screw connections • Loose dipstick • Oil level high during operation • Unknown | <ul style="list-style-type: none"> • Tighten to specification • Tighten, replace • Tighten, replace • Pump out oil to max. mark on dipstick • Consult authorized Yanmar marine distributor or dealer |
| 3. Shifts hard | <ul style="list-style-type: none"> • Selector control • Linkage • Unknown | <ul style="list-style-type: none"> • Consult authorized Yanmar marine distributor or dealer • Adjust • Consult authorized Yanmar marine distributor or dealer |
| 4. Slow engagement | <ul style="list-style-type: none"> • Selector control • Linkage • Unknown | <ul style="list-style-type: none"> • Consult authorized Yanmar marine distributor or dealer • Adjust • Consult authorized Yanmar marine distributor or dealer |
| 5. No movement of the boat | <ul style="list-style-type: none"> • Selector control • Improper selector position • Propeller missing • Propeller shaft broken • Sail drive malfunction • Engine malfunction | <ul style="list-style-type: none"> • Consult service station • Adjust • Replace • Consult authorized Yanmar marine distributor or dealer • Consult authorized Yanmar marine distributor or dealer • Consult authorized Yanmar marine distributor or dealer |

SPECIFICATIONS

| | | SD60-5 Standard, Extension | | SD60-4 Standard, Extension | |
|--------------------------------------|--------------------|--|------|---|------|
| Reduction gear system | | Multiple friction disc | | | |
| Direction of rotation | Input shaft | Counter-clockwise viewed from stern | | | |
| | Propeller shaft | Counter-clockwise or clockwise viewed from stern | | | |
| Reduction ratio | Ahead | 2.23 | 2.49 | 2.23 | 2.49 |
| | Astern | 2.23 | 2.49 | 2.23 | 2.49 |
| Propeller speed (min ⁻¹) | | 1345 | 1205 | 1435 | 1285 |
| Lubrication oil | | 15W-40 | | | |
| Lubrication oil capacity (liter) | Standard (S) | 2.8 | | | |
| | With extension (L) | 3.0 | | | |
| Dry weight (kg) | Standard (S) | 44 | | 45 | |
| | With extension (L) | 48 | | 49 | |
| Applicable engine model | | 3JH5CE (28.7 kW/3000 min ⁻¹) | | 4JH4-TCE (55.2 kW/3200 min ⁻¹) | |
| | | 3JH5AE-C (28.7 kW/3000 min ⁻¹) | | | |
| | | 4JH5CE (39.6 kW/3000 min ⁻¹) | | | |
| | | 3JH40-C (29.4 kW/3000 min ⁻¹) | | 4JH80-C (58.8 kW/3200 min ⁻¹) | |
| | | 4JH45-C (33.1 kW/3000 min ⁻¹) | | | |
| | | 4JH57-C (41.9 kW/3000 min ⁻¹) | | | |

This Page Intentionally Left Blank

YANMAR CO., LTD.

■ Large Power Products Management Division

Quality Assurance Division

5-3-1, Tsukaguchi-honmachi, Amagasaki

Hyogo, 661-0001, Japan

Phone: +81-6-6428-3137 Fax: +81-6-6421-5549

<https://www.yanmar.com/>

■ Yanmar Marine International B.V.

Brugplein 11, 1332 BS Almere-de Vaart, Netherlands

Phone: +31-36-5493534 Fax: +31-36-5493219

<http://www.yanmarmarine.com/>

Overseas Office

■ Yanmar Europe B.V. (YEU)

Brugplein 11, 1332 BS Almere-de Vaart, Netherlands

Phone: +31-36-5493200 Fax: +31-36-5493209

<http://www.yanmar.com/eu/>

■ Yanmar Asia (Singapore) Corporation Pte. Ltd. (YASC)

4 Tuas Lane, Singapore 638613

Phone: +65-6861-3855 Fax: +65-6862-5189

<https://www.yanmar.com/sg/>

■ Yanmar America Corporation (YA)

101 International Parkway,

Adairsville, GA 30103, U.S.A.

Phone: +1-770-877-9894 Fax: +1-770-877-9009

<http://www.yanmar.com/us/>

■ Yanmar Engine (Shanghai) Co., Ltd.

10F, E-Block Poly Plaza, No.18 Dongfang Road,

Pudong Shanghai, China P.R.C. 200120

Phone: +86-21-6880-5090 Fax: +86-21-6880-8090

<https://www.yanmar.com/cn/>

As of November 1st, 2017

OPERATION MANUAL

SD60

1st edition: April 2013

2nd edition: November 2016

3rd edition: January 2018

Issued by: YANMAR CO., LTD. Large Power Products Management Division

Edited by: YANMAR TECHNICAL SERVICE CO., LTD.

YANMAR

YANMAR CO., LTD.

<https://www.yanmar.com>

0ASDM-EN0022
30.1(YTSK)