



OPERATION MANUAL

MARINE ENGINES

3JH40

4JH45

4JH57

4JH80

4JH110

 English

YANMAR

**California
Proposition 65 Warning**

Diesel engine exhaust and some of its constituents are known to the state of California to cause cancer, birth defects, and other reproductive harm.

**California
Proposition 65 Warning**

Battery posts, terminals, and related accessories contain lead and lead compounds, chemicals known to the state of California to cause cancer and reproductive harm.
Wash hands after handling.

Disclaimers:

All information, illustrations and specifications in this manual are based on the latest information available at the time of publishing. The illustrations used in this manual are intended as representative reference views only. Moreover, because of our continuous product improvement policy, we may modify information, illustrations and/or specifications to explain and/or exemplify a product, service or maintenance improvement. We reserve the right to make any change at any time without notice. Yanmar and **YANMAR** are registered trademarks of YANMAR CO., LTD. in Japan, the United States and/or other countries.

All Rights Reserved:

No part of this publication may be reproduced or used in any form by any means - graphic, electronic, or mechanical, including photocopying, recording, taping, or information storage and retrieval systems - without the written permission of YANMAR CO., LTD.

Please review and comply with the applicable laws and regulations of the international export control regimes at the territory or country where the product and manual are intended to be imported and used.

OPERATION MANUAL	MODEL	3JH40, 4JH45, 4JH57, 4JH80, 4JH110
	CODE	0AJHC-EN0014

TABLE OF CONTENTS

	Page
INTRODUCTION	1
RECORD OF OWNERSHIP	2
SAFETY	3
SAFETY PRECAUTIONS	4
General Information	4
Before You Operate	4
During Operation and Maintenance	4
LOCATION OF SAFETY DECALS	8
PRODUCT OVERVIEW	11
YANMAR 3/4JH COMMON RAIL SERIES	
FEATURES AND APPLICATIONS	11
New Engine Break-In	12
COMPONENT IDENTIFICATION	13
Right Side (Viewed from Flywheel) - 3JH40	13
Left Side (Viewed from Flywheel) - 3JH40	13
Right Side (Viewed from Flywheel)	
- 4JH45/4JH57	14
Left Side (Viewed from Flywheel)	
- 4JH45/4JH57	14
Right Side (Viewed from Flywheel)	
- 4JH80/4JH110	15
Left Side (Viewed from Flywheel)	
- 4JH80/4JH110	15
NAMEPLATES	16
FUNCTION OF MAJOR COMPONENTS	17
ELECTRONIC CONTROL SYSTEM	18
MAIN ELECTRONIC CONTROL COMPONENTS	
AND FEATURES	19

TABLE OF CONTENTS

CONTROL EQUIPMENT	20
Instrument Panel (Optional)	20
Accessory power output.....	30
Single-Lever Remote Control Handle	31
VESSEL CONTROL SYSTEM (VC10).....	32
Display	33
BEFORE YOU OPERATE	37
INTRODUCTION	37
SAFETY PRECAUTIONS.....	37
DIESEL FUEL.....	38
Diesel Fuel Specifications	38
Filling the Fuel Tank.....	41
Bleeding the Fuel System	42
Priming the Fuel System	43
ENGINE OIL	43
Engine Oil Specifications	43
Engine Oil Viscosity	44
Checking the Engine Oil.....	44
Adding Engine Oil	45
MARINE GEAR OR SAIL DRIVE OIL	45
Marine Gear Oil Specifications.....	45
Sail Drive Oil Specifications	45
Checking Marine Gear Oil.....	46
Adding Marine Gear Oil.....	46
Checking and Adding Sail Drive Oil	46
ENGINE COOLANT	47
Engine Coolant Specifications	47
Coolant (Closed Cooling System)	47
Checking and Adding Coolant.....	48
ENGINE OPERATION	53
INTRODUCTION	53
SAFETY PRECAUTIONS.....	53
OPERATION	
(B25,C35-TYPE INSTRUMENT PANEL)	55
Starting the Engine.....	55
If the Engine Fails to Start.....	56
Starting at Low Temperatures.....	56
After the Engine has Started	57
REMOTE CONTROL HANDLE OPERATION	57
Acceleration and Deceleration	57
Shifting the Engine	57
Switching to Trolling (KMH4A Only).....	58

CAUTIONS DURING OPERATION	59
SHUTTING DOWN THE ENGINE	61
Normal Shutdown	61
Engine Auxiliary Stop Switch	62
Auxiliary Stop Switch (Option: It is recommended that this switch is installed in an easily accessible location.)	63
CHECKING THE ENGINE AFTER OPERATION	63
OPERATION	
(VC10: VESSEL CONTROL SYSTEM)	64
Starting the Engine	64
Station Protect	66
Sys on by ID, Start by ID	66
Owner ID Change	66
If the Engine Fails to Start	67
Starting at Low Temperatures	67
After the Engine has Started	67
WARM UP MODE (SHIFT DISCONNECT)	68
THROTTLE AND SHIFT CONTROL.....	69
Neutral	69
Forward	69
Reverse	69
Forward (Reverse) to Reverse (Forward).....	69
ENGINE SPEED LIMIT MODE	70
CAUTIONS DURING OPERATION	70
SHUT-DOWN THE ENGINE (STOPPING).....	72
Normal Stopping	72
Emergency Stop	73
CONTROL THE BACKUP PANEL.....	74
CHECKING THE ENGINE AFTER OPERATION	75
PERIODIC MAINTENANCE	77
INTRODUCTION.....	77
SAFETY PRECAUTIONS	77

TABLE OF CONTENTS

PRECAUTIONS.....	79
The Importance of Periodic Maintenance	79
Performing Periodic Maintenance	79
The Importance of Daily Checks	79
Keep a Log of Engine Hours and Daily Checks .	79
Yanmar Replacement Parts	79
Tools Required.....	79
Consult Your Authorized Yanmar Marine Dealer or Distributor for Help	79
Tightening Fasteners	80
EPA MAINTENANCE REQUIREMENTS	82
EPA Requirements for USA and Other Applicable Countries	82
EPA Requirements.....	82
Conditions to Ensure Compliance with EPA Emission Standards.....	83
Inspection and Maintenance	84
Installation of Exhaust Sampling Port	84
PERIODIC MAINTENANCE SCHEDULE	85
Inspection and Maintenance of Emission-Related Parts.....	87
PERIODIC MAINTENANCE PROCEDURES.....	88
Daily Checks	88
After Initial 50 Hours of Operation.....	89
Every 50 Hours of Operation.....	95
Every 250 Hours of Operation.....	97
Every 500 Hours of Operation.....	104
Every 1000 Hours of Operation.....	105
TROUBLESHOOTING.....	107
SAFETY PRECAUTIONS.....	107
TROUBLESHOOTING AFTER STARTING	107
TROUBLESHOOTING INFORMATION	108
TROUBLESHOOTING CHART	109
FAILSAFE DIAGNOSIS FUNCTIONAL SPECIFICATION CHART.....	114
LONG-TERM STORAGE.....	119
PREPARE ENGINE FOR LONG-TERM STORAGE	119
DRAIN SEAWATER COOLING SYSTEM.....	120
RETURNING THE ENGINE TO SERVICE	122

SPECIFICATIONS	123
PRINCIPAL ENGINE SPECIFICATIONS	123
3JH40 Engine	124
3JH40 Marine Gear or Sail Drive.....	125
4JH45 Engine	126
4JH57 Engine	127
4JH45, 4JH57 Marine Gear or Sail Drive	128
4JH80 Engine	129
4JH110 Engine	130
4JH80, 4JH110 Marine Gear or Sail Drive	131
SYSTEM DIAGRAMS	133
PIPING DIAGRAMS.....	133
WIRING DIAGRAMS.....	149
3JH40	150
4JH45, 4JH57, 4JH80, 4JH110	158
WARRANTY USA ONLY	167
YANMAR CO., LTD. LIMITED EMISSION CONTROL SYSTEM WARRANTY - USA ONLY ...	167
YANMAR EMISSION CONTROL SYSTEM WARRANTY STATEMENT	169
YOUR WARRANTY RIGHTS AND OBLIGATIONS:.....	169
Yanmar's warranty coverage:.....	169
Warranted Parts:	170
Exclusions:	170
Owners Warranty Responsibilities:.....	171
Customer Assistance:.....	171
Maintenance Log	172

This Page Intentionally Left Blank

INTRODUCTION

Welcome to the world of Yanmar Marine! Yanmar Marine offers engines, drive systems and accessories for all types of boats, from runabouts to sailboats, and from cruisers to mega yachts. In marine leisure boating, the worldwide reputation of Yanmar Marine is second to none. We design our engines to respect nature. This means quieter engines, with minimal vibrations, cleaner than ever. All of our engines meet applicable regulations, including emissions, at the time of manufacture.

To help you enjoy your Yanmar JH series engine for many years to come, please follow these recommendations:

- Read and understand this *Operation Manual* before you operate the machine to ensure that you follow safe operating practices and maintenance procedures.
- Keep this *Operation Manual* in a convenient place for easy access.
- If this *Operation Manual* is lost or damaged, order a new one from your authorized Yanmar Marine dealer or distributor.
- Make sure this manual is transferred to subsequent owners. This manual should be considered a permanent part of the engine and remain with it.
- Constant efforts are made to improve the quality and performance of Yanmar products, so some details included in this *Operation Manual* may differ slightly from your engine. If you have any questions about these differences, please consult your authorized Yanmar Marine dealer or distributor.
- The specifications and components (instrument panel, fuel tank, etc.) described in this manual may differ from ones installed on your vessel. Please refer to the manual provided by the manufacturer of these components.
- Refer to the Yanmar Limited Warranty Handbook for a complete warranty description.

INTRODUCTION

RECORD OF OWNERSHIP

Take a few moments to record the information you need when you contact Yanmar for service, parts or documentation.

Engine Model: _____

Engine Serial No.: _____

Date Purchased: _____

Dealer: _____

Dealer Phone: _____

SAFETY

Yanmar considers safety of great importance and recommends that anyone that comes into close contact with its products, such as those who install, operate, maintain or service Yanmar products, exercise care, common sense and comply with the safety information in this manual and on the machine's safety decals. Keep the labels from becoming dirty or torn and replace them if they are lost or damaged. Also, if you need to replace a part that has a label attached to it, make sure you order the new part and label at the same time.



This safety alert symbol appears with most safety statements. It means attention, become alert, your safety is involved! Please read and abide by the message that follows the safety alert symbol.

DANGER

Indicates a hazardous situation which, if not avoided, *will* result in death or serious injury.

WARNING

Indicates a hazardous situation which, if not avoided, *could* result in death or serious injury.

CAUTION

Indicates a hazardous situation which, if not avoided, *could* result in minor or moderate injury.

NOTICE

Indicates a situation which can cause damage to the machine, personal property and/or the environment, or cause the equipment to operate improperly.

SAFETY PRECAUTIONS

General Information

There is no substitute for common sense and careful practices. Improper practices or carelessness can cause burns, cuts, mutilation, asphyxiation, other bodily injury or death. This information contains general safety precautions and guidelines that must be followed to reduce risk to personal safety. Special safety precautions are listed in specific procedures. Read and understand all of the safety precautions before operation or performing repairs or maintenance.

Before You Operate

DANGER

The safety messages that follow have DANGER level hazards.



Never permit anyone to install or operate the engine without proper training.

Read and understand this *Operation Manual* before you operate or service the engine to ensure that you follow safe operating practices and maintenance procedures.

- Safety signs and labels are additional reminders for safe operating and maintenance techniques.
- Consult authorized Yanmar Marine dealer or distributor for additional training.

During Operation and Maintenance

WARNING

The safety messages that follow have WARNING level hazards.

Explosion Hazard



While the engine is running or the battery is charging, hydrogen gas is being produced and can be easily ignited. Keep the area around the battery

well-ventilated and keep sparks, open flames and any other form of ignition out of the area.

Fire and Explosion Hazard

Diesel fuel is flammable and explosive under certain conditions.

Never use a shop rag to catch the fuel.

Wipe up all spills immediately.

Never refuel with the engine running.

Fire Hazard



Undersized wiring systems can cause an electrical fire. Never use improper capacity of fuses.

Store any containers containing fuel or other flammable products in a well-ventilated area, away from any combustibles or source of ignition.

Store any equipment in a designated area away from moving parts.

Never use the engine compartment for storage.

⚠ WARNING**Sever Hazard**

Rotating parts can cause severe injury or death. Never wear jewelry, unbuttoned cuffs, ties or loose-fitting clothing and always tie long hair back when working near moving/rotating parts such as the flywheel or PTO shaft. Keep hands, feet and tools away from all moving parts.

Alcohol and Drug Hazard

Never operate the engine while under the influence of alcohol or drugs, or when feeling ill.

Exposure Hazard

Always wear personal protective equipment including appropriate clothing, gloves, work shoes, and eye and hearing protection as required by the task at hand.

Sudden Movement Hazard

Never operate the engine while wearing a headset to listen to music or radio because it will be difficult to hear the warning signals.

Burn Hazard

Some of the engine surfaces become very hot during operation and shortly after shutdown. Keep hands and other body parts away from hot engine surfaces.

Exhaust Hazard

Never block windows, vents or other means of ventilation if the engine is operating in an enclosed area. All internal combustion engines create carbon monoxide gas during operation and special precautions are required to avoid carbon monoxide poisoning.

CAUTION

The safety messages that follow have CAUTION level hazards.

Poor Lighting Hazard

Ensure that the work area is adequately illuminated. Always install wire cages on portable safety lamps.

Tool Hazard

Always use tools appropriate for the task at hand and use the correct size tool for loosening or tightening machine parts.

Flying Object Hazard

Always wear eye protection when servicing the engine or when using compressed air or high-pressure water. Dust, flying debris, compressed air, pressurized water or steam may injure your eyes.

Coolant Hazard



Wear eye protection and rubber gloves when you handle engine coolant. If contact with the eyes or skin should occur, flush eyes and wash immediately with clean water.

NOTICE

The safety messages that follow have NOTICE level hazards.

It is important to perform daily checks as listed in the *Operation Manual*. Periodic maintenance prevents unexpected downtime, reduces the number of accidents due to poor engine performance and helps extend the life of the engine.

Consult authorized Yanmar Marine dealer or distributor if you need to operate the engine at high altitudes. At high altitudes the engine will lose power, run rough and produce exhaust gases that exceed the design specifications.

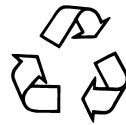

Always be environmentally responsible.

Follow the guidelines of the EPA or other governmental agencies for the proper disposal of hazardous materials such as engine oil, diesel fuel and engine coolant. Consult the local authorities or reclamation facility.

Never dispose of hazardous materials by dumping them into a sewer, on the ground, or into ground water or waterways.

If a Yanmar Marine Engine is installed at an angle that exceeds the specifications stated in the Yanmar Marine *Installation Manuals*, engine oil may enter the combustion chamber causing excessive engine speed, white exhaust smoke and serious engine damage. This applies to engines that run continuously or those that run for short periods of time.

NOTICE

If you have an installation with two or three engines and only one engine is operating, the water pickup (thru-hull) of the non-running engine(s) should be closed. This will prevent water from being forced past the seawater pump and eventually finding its way into the engine. The result of water entering the engine could cause seizure or other serious problems.

If you have an installation with two or three engines, and only one engine is operating, please note that if the propeller shaft thru-hull (stuffing box) is lubricated by engine water pressure and the engines are interconnected, care must be taken that water from the running engine does not enter the exhaust of the non-running engine(s). This water could cause seizure of the non-running engine(s). Consult authorized Yanmar Marine dealer or distributor for a complete explanation of this condition.

If you have an installation with two or three engines, and only one engine is operating, it is important to limit the amount of throttle applied to the running engine. If you observe black smoke or movement of the throttle does not increase engine speed, you are overloading the engine that is running. Immediately throttle back to approximately 2/3 throttle or to a setting where the engine performs normally. Failure to do so may cause the running engine to overheat or cause excess carbon buildup which may shorten the engine's life.

Never turn off the battery switch (if equipped) or short the battery cables during operation. Damage to the electrical system will result.

LOCATION OF SAFETY DECALS

Figure 1, Figure 2 and Figure 3 show the location of safety decals on Yanmar 3JH40, 4JH45/57 and 4JH80/110 series marine engines.

3JH40 Engine

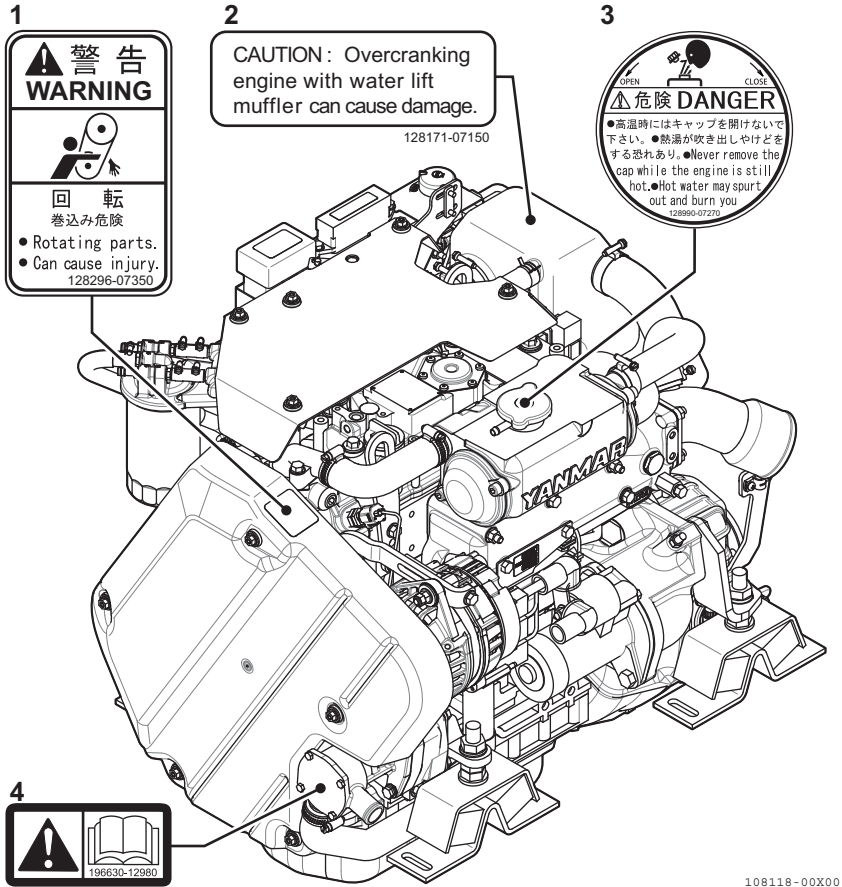

Figure 1

1–Part Number: 128296-07350

2–Part Number: 128171-07150

3–Part Number: 128990-07270

4–Part Number: 196630-12980

4JH45/4JH57 Engines

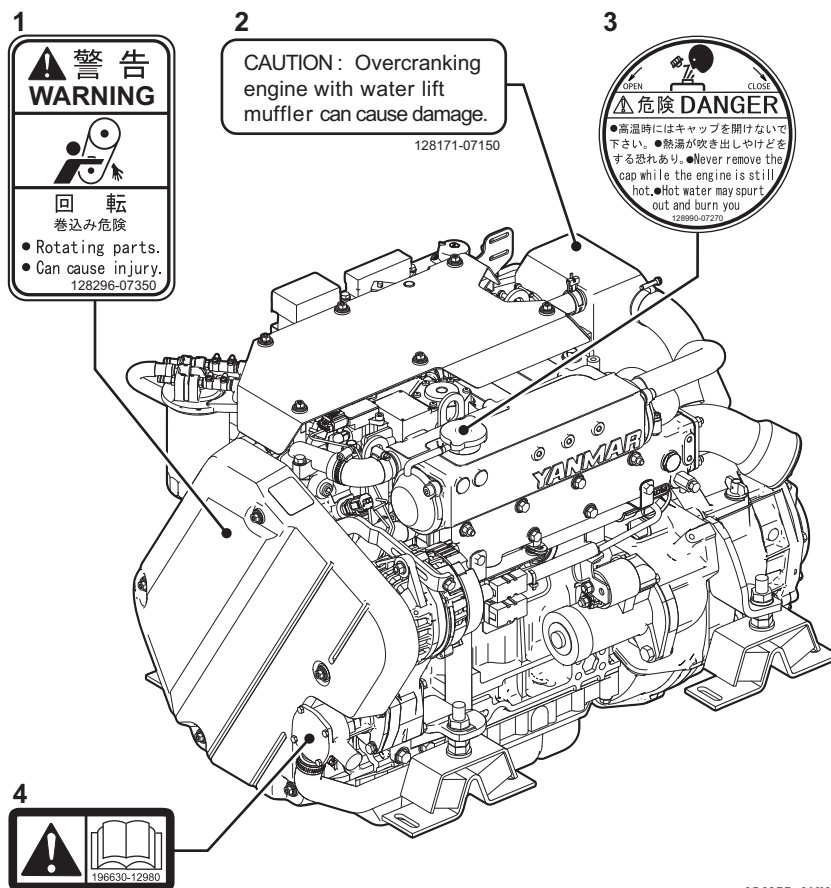

056977-01X01

Figure 2

1-Part Number: 128296-07350

2-Part Number: 128171-07150

3-Part Number: 128990-07270

4-Part Number: 196630-12980

4JH80/4JH110 Engines

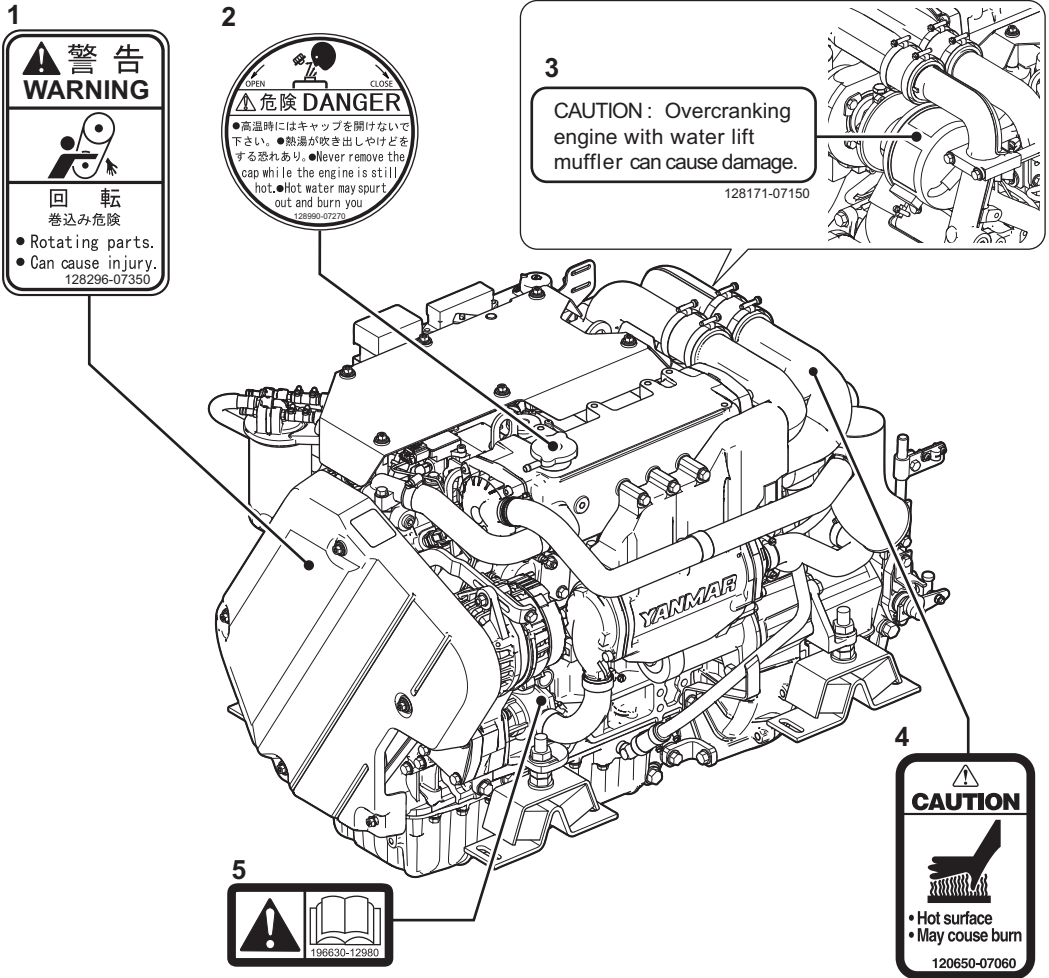

056978-02X01

Figure 3

- 1-Part Number: 128296-07350**
- 2-Part Number: 128990-07270**
- 3-Part Number: 128171-07150**
- 4-Part Number: 120650-07060**
- 5-Part Number: 196630-12980**

PRODUCT OVERVIEW

YANMAR 3/4JH COMMON RAIL SERIES FEATURES AND APPLICATIONS

The 3/4JH common rail series are four-stroke diesel engines equipped with direct injection common rail system and with liquid coolant systems.

The 3JH40 is 3-cylinder and naturally aspirated.

The 4JH45, 4JH57 are 4-cylinder and naturally aspirated.

The 4JH80, 4JH110 are 4-cylinder and turbocharged with an air cooler.

The engines are equipped with a marine gear or sail drive unit.

These engines are designed for recreational craft use.

Failure to do so can lead to reduced vessel performance, lead to increased smoke levels and cause permanent damage to your engine.

The engine must be installed correctly with coolant lines, exhaust gas lines and electrical wiring. Any auxiliary equipment attached to the engine should be easy to use and accessible for service. To handle the drive equipment, propulsion systems (including the propeller) and other inboard equipment, always observe the instructions and cautions given in the operation manuals supplied by the shipyard and equipment manufacturers.

The 3/4JH common rail series engines are designed to be operated at maximum throttle*¹ for less than 5% of total engine time (30 minutes out of every 10 hours) and cruising speed*².

The laws of some countries may require hull and engine inspections, depending on the use, size and cruising area of the boat. The installation, fitting and surveying of this engine all require specialized knowledge and engineering skills. See Yanmars local subsidiary in your region or your authorized Yanmar Marine dealer or distributor.

*¹ maximum throttle: fuel stop power engine speed

*² cruising speed: fuel stop power engine speed -200 min^{-1} or less

PRODUCT OVERVIEW

New Engine Break-In

As with all reciprocating engines, the way your engine is operated during its first 50 hours of operation plays a very significant role in determining how long it will last and how well the engine will perform over its lifetime.

A new Yanmar diesel engine must be operated at suitable speeds and power settings during the break-in period to make the sliding parts, such as piston rings, break-in properly and to stabilize engine combustion.

During the break-in period, the engine coolant temperature gauge should be monitored; temperature should be between 71° and 87°C (160° and 190°F).

During the first 10 hours of operation, the engine should be run at maximum engine speed minus 400 to 500 min⁻¹ (approximately 60 to 70% of load) most of the time. This will ensure the sliding parts break in properly. During this period, avoid operating at maximum engine speed and load to avoid damaging or scoring sliding parts.

NOTICE

Do not operate at WOT (wide open throttle) for more than a minute at a time during the first 10 hours of operation.

Do not operate the engine at low idle or at low speed and light load for more than 30 minutes at a time. Since unburned fuel and engine oil will adhere to the piston rings when operating at low speeds for long periods, this will interfere with proper movement of the rings and the engine oil consumption may increase. Low idle speed does not allow break-in of sliding parts.

If operating engine at low speed and light load, you must race the engine to clean the carbon from the cylinders and fuel injection valve.

Perform this procedure in open waters:

- With the clutch in NEUTRAL, accelerate from the low-speed position to the high-speed position briefly.
- Repeat this process five times.

Once past the initial 10 hours until 50 hours, the engine should be used over its full operating range, with special emphasis on running at relatively high power settings. This is not the time for an extended cruise at idle or low speed. The boat should be run at maximum speed minus 400 min⁻¹ most of the time (approximately 70% load), with a 10 minute run at maximum minus 200 min⁻¹ (approximately 80% load) every 30 minutes and a 4 to 5 minute period of operation at WOT (wide open throttle) once each 30 minutes. During this period, be sure not to operate your engine at low speed and light load for more than 30 minutes. If operating engine at low speed and light load by necessity, just after the low idle operation, be sure to race the engine.

To complete engine break-in, perform *After Initial 50 Hours of Operation* maintenance procedures. *After Initial 50 Hours of Operation* on page 89.

COMPONENT IDENTIFICATION

Figure 1 and Figure 2 illustrate a typical version of a 3JH40 engine. Your engine may have different equipment from that illustrated.

Right Side (Viewed from Flywheel) - 3JH40

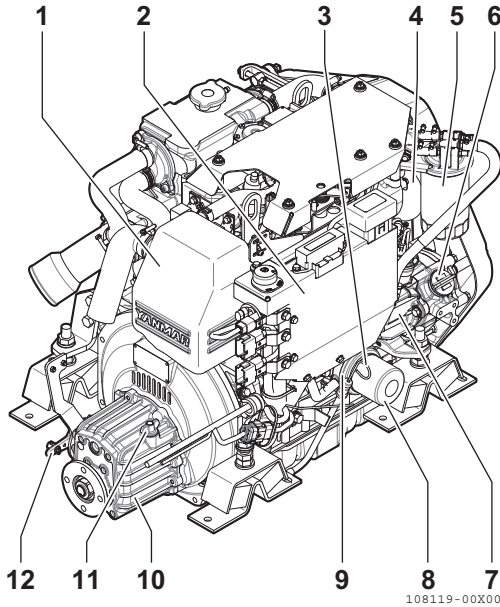

Figure 1

- 1 – Intake silencer
- 2 – ECU cover
- 3 – Engine oil dipstick
- 4 – Intake manifold
- 5 – Fuel filter
- 6 – Engine oil filler cap
- 7 – Fuel supply pump
- 8 – Engine oil filter
- 9 – Engine oil cooler
- 10 – Marine gear (KM35P)
- 11 – Marine gear oil dipstick
- 12 – Shift lever

Left Side (Viewed from Flywheel) - 3JH40

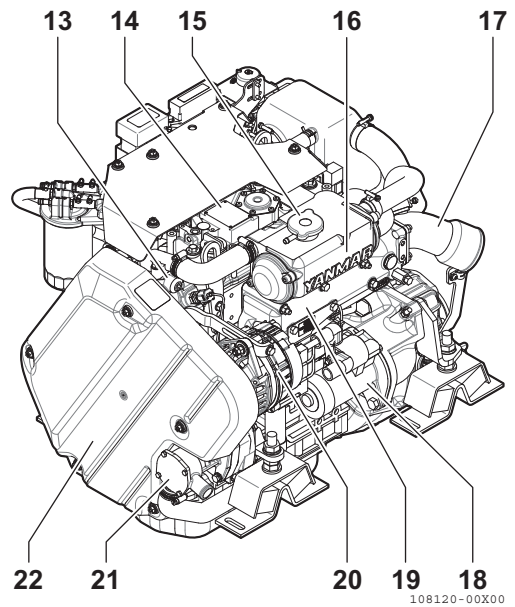

Figure 2

- 13 – Coolant pump
- 14 – Engine nameplate (on rocker arm cover)
- 15 – Coolant filler cap
- 16 – Coolant tank/Heat exchanger
- 17 – Exhaust/water mixing elbow
- 18 – Starter motor
- 19 – Exhaust manifold
- 20 – Alternator
- 21 – Seawater pump
- 22 – Belt cover

PRODUCT OVERVIEW

Figure 3 and Figure 4 illustrate a typical version of a 4JH45/4JH57 engine. Your engine may have different equipment from that illustrated.

Right Side (Viewed from Flywheel) - 4JH45/4JH57

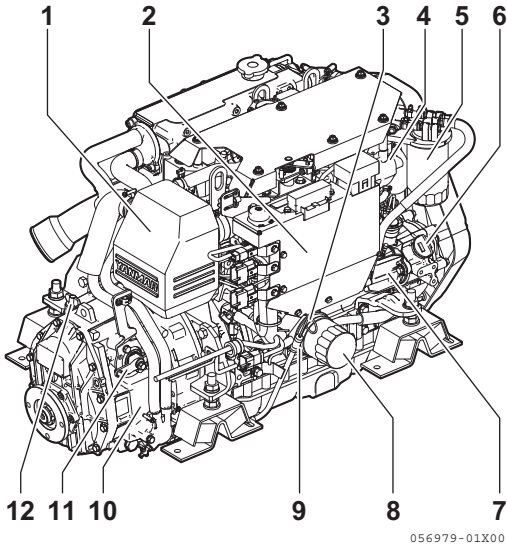

Figure 3

- 1 – Intake silencer
- 2 – ECU cover
- 3 – Engine oil dipstick
- 4 – Intake manifold
- 5 – Fuel filter
- 6 – Engine oil filler cap
- 7 – Fuel supply pump
- 8 – Engine oil filter
- 9 – Engine oil cooler
- 10 – Marine gear (KM4A1)
- 11 – Shift lever
- 12 – Marine gear oil dipstick

Left Side (Viewed from Flywheel) - 4JH45/4JH57

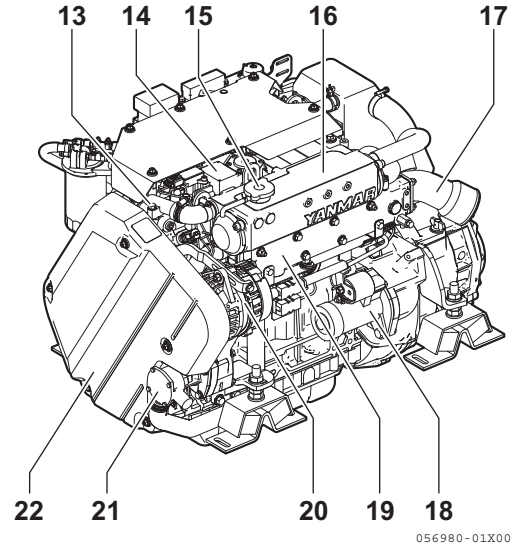

Figure 4

- 13 – Coolant pump
- 14 – Engine nameplate (on rocker arm cover)
- 15 – Coolant filler cap
- 16 – Coolant tank/Heat exchanger
- 17 – Exhaust/water mixing elbow
- 18 – Starter motor
- 19 – Exhaust manifold
- 20 – Alternator
- 21 – Seawater pump
- 22 – Belt cover

Figure 5 and Figure 6 illustrate a typical version of a 4JH80/4JH110 engine. Your engine may have different equipment from that illustrated.

Right Side (Viewed from Flywheel) - 4JH80/4JH110

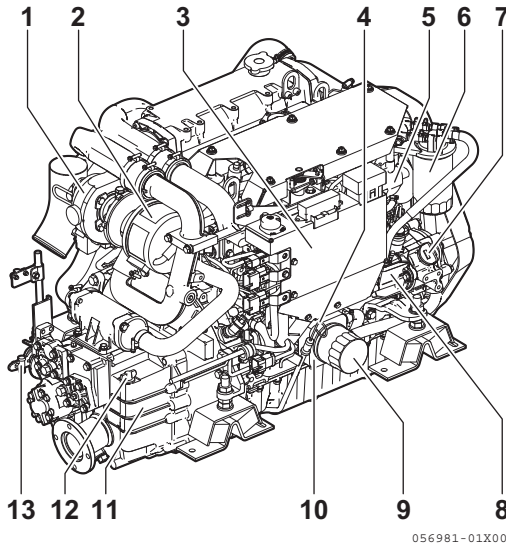

Figure 5

- 1 – Turbocharger
- 2 – Intake silencer (Air cleaner)
- 3 – ECU cover
- 4 – Engine oil dipstick
- 5 – Intake manifold
- 6 – Fuel filter
- 7 – Engine oil filler cap
- 8 – Fuel supply pump
- 9 – Engine oil filter
- 10 – Engine oil cooler
- 11 – Marine gear (KMH4A)
- 12 – Marine gear oil dipstick
- 13 – Shift lever

Left Side (Viewed from Flywheel) - 4JH80/4JH110

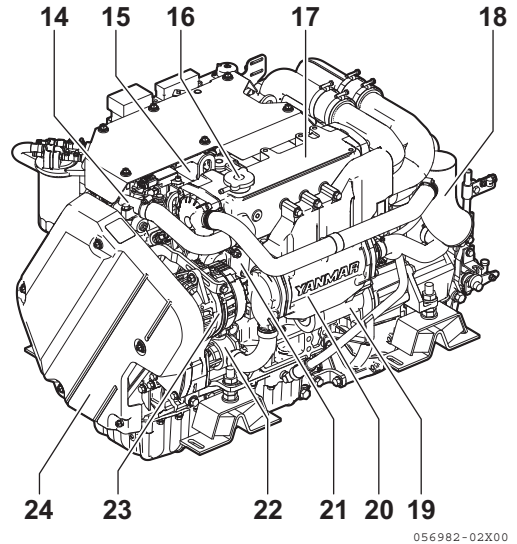

Figure 6

- 14 – Coolant pump
- 15 – Engine nameplate (on rocker arm cover)
- 16 – Coolant filler cap
- 17 – Coolant tank/Heat exchanger
- 18 – Exhaust/water mixing elbow
- 19 – Starter motor
- 20 – Air cooler
- 21 – Exhaust manifold
- 22 – Seawater pump
- 23 – Alternator
- 24 – Belt cover

PRODUCT OVERVIEW

NAMEPLATES

The nameplates of Yanmar 3/4JH common rail series engines are shown in **Figure 7**. Check the engine's model, output, min^{-1} and serial number on the nameplate. Please replace if damaged or lost.

The engine nameplate is attached to the engine rocker arm cover.

Model	_____
Gear Model	_____
Continuous power kW	_____ / _____ min^{-1}
Speed of prop.shaft	_____ min^{-1} _____
Fuel stop power kW	_____ / _____ min^{-1}
ENG.No.	_____
MFG.DATE	_____ / _____
YANMAR YANMAR CO.,LTD. MADE IN JAPAN	

129670-07201

Figure 7

The marine gear nameplate (**Figure 8**) is attached to the marine gear. Check the marine gears model, gear ratio, oil used and serial number.

MODEL	_____
MFG. NO.	_____
GEAR RATIO	_____
OIL	_____
YANMAR KANZAKI KOKYUKOKI MFG CO., LTD. MADE IN JAPAN	

177524-02903

Figure 8

The sail drive nameplate (**Figure 9**) is attached to the sail drive. Check the sail drive model and serial number.

MODEL	_____
GEAR RATIO	_____
MFG.NO.	_____
P/N	_____
OIL TYPE	_____
YANMAR YANMAR CO., LTD. MADE IN EU	

196460-02120

Figure 9

FUNCTION OF MAJOR COMPONENTS

Name of Component	Function
Fuel Filter	The fuel filter removes contaminants and sediments from the diesel fuel. Periodic replacement of the fuel filter is necessary. <i>See Periodic Maintenance Schedule on page 85</i> for the replacement frequency.
Fuel pre-filter (Water separator)	The water separator removes contaminants, sediment and water from diesel fuel going to the fuel filter. This is a required component of the fuel system and is standard equipment with every engine. The water separator is installed between the fuel tank and the fuel filter. Periodically drain the water from the water separator using the drain cock at the bottom of the separator and replace the filter element.
Fuel Priming Pump	This is a manual fuel pump. Pushing the knob on the top of the fuel pre-filter feeds the fuel. This pump is also used to bleed air from the fuel system.
Engine Oil Filler Port	Filler port for engine oil.
Engine Oil Filter	Filters fine metal fragments and carbon from the engine oil. Filtered engine oil is distributed to the engine's moving parts. The filter is a cartridge type and the element should be replaced periodically. <i>See Changing the Engine Oil and Replacing the Engine Oil Filter Element on page 99.</i>
Marine Gear Filler Port	Filler port for marine gear lube oil. Located on top of the marine gear case.
Cooling System	There are two cooling systems: closed cooling with coolant and seawater. The engine is cooled by the closed cooling circuit. The closed circuit is cooled by seawater using a heat exchanger. The seawater also cools the marine gear oil and intake air (depending on model) through the cooler(s) in an open circuit.
Coolant pump	The centrifugal water pump circulates coolant inside the engine. The circulating pump is driven by a V-ribbed belt.
Seawater Pump	Pumps seawater from outside vessel to the engine. The seawater pump is gear-driven and has a replaceable rubber impeller. Do not operate it without seawater, as this will damage the impeller.
Reservoir	The pressure valve in the filler cap releases vapor and hot water overflow to the reservoir. When the engine stops and the coolant cools, the pressure in coolant tank drops. The filler cap vacuum valve then opens to send water back from the reservoir. This minimizes coolant consumption. The closed cooling system coolant level can easily be checked and refilled in this tank.
Oil Cooler - Engine	A heat exchanger that cools high temperature engine oil using coolant.
Oil Cooler - Marine Gear (Optional)	This heat exchanger cools the marine gear (KMH4A) oil using seawater.
Turbocharger (if equipped)	The turbocharger pressurizes the air coming into the engine. It is driven by a turbine that is energized by exhaust gases.
Air cooler (if equipped)	This heat exchanger cools the pressurized charging air from the turbocharger with seawater to increase the charging air quantity.
Intake Silencer (Air Cleaner)	The intake silencer guards against dirt in the air and reduces the noise of air intake.
Nameplates	Nameplates are provided on the engine and the marine gear and have the model, serial number and other data.
Starter	Starter motor for the engine. Powered by the battery.
Alternator	Driven by belt and generates electricity and charges the battery.
Engine Oil Dipstick	Gauge stick for checking the engine oil level.

ELECTRONIC CONTROL SYSTEM

WARNING

- The 3/4JH common rail series engines use a high pressure common rail system.
 - The fuel is injected at extremely high pressure.
 - Never disassemble the fuel system parts.
 - Failure to comply may result in death or serious injury.
 - If a malfunction occurs, consult your nearest Yanmar dealer or distributor.
-
- Never use the ECU for other purposes than intended or in other ways than specified by Yanmar. Doing so could result in the violation of emission control regulations and will void the product warranty.
 - Be sure to use the ECU in conjunction with the engines whose models or serial numbers are specified by Yanmar. Other ECU/engine combinations than specified will void the engine warranty.
 - Replacing the fuel injector involves rewriting the fuel injection data in the ECU. Be sure to consult your local Yanmar dealer before replacing the fuel injector. Failure to rewrite the fuel injection data before replacing the fuel injector will void the engine warranty.
 - Improper use or misuse of the ECU may result in death or serious injury due to an abrupt and unexpected increase in engine speed.

- Replacing the ECU involves migrating the fuel injection data to the existing ECU to the new unit. Be sure to consult your local Yanmar dealer before replacing the ECU. Failure to migrate the fuel injection data before replacing the ECU will void the engine warranty.

NOTICE

- Do not plug or unplug the ECU for a period of at least 6 seconds after power to the unit has been turned on or off.
 - Do not touch connector pins of the ECU with bare hands. Doing so may result in corrosion of the connector pins and/or damage to the internal circuits of the ECU due to static electricity.
 - Do not force a measuring probe into the female coupler. Doing so may cause contact failure of the connector pins, resulting in malfunction of the ECU.
 - Take care to prevent water from entering the couplers when plugging or unplugging the connector. Water inside the couplers may cause corrosion, resulting in malfunction of the ECU.
 - Avoid plugging/unplugging the connector more than approx. 10 times. Frequent plugging/unplugging of the connector may cause contact failure of the connector pins, resulting in malfunction of the ECU.
 - Do not use the ECU that has ever suffered drop impact.
-
- Always check the battery for proper charge. Otherwise the electronically controlled engines may fail to start.
-

MAIN ELECTRONIC CONTROL COMPONENTS AND FEATURES

Component/feature	Description
Controller	By controlling the fuel injection timing, volume, pressure and number in accordance with the target speed indication entered from the accelerator sensor, the controller adjusts the engine speed and power.
Fuel pump (supply pump)	The fuel pump supplies fuel to the common rail.
Common rail	The common rail stores the compressed high-pressure fuel from the supply pump and distributes fuel to the injector in each cylinder.
Fuel injector	The Fuel Injectors the high-pressure fuel from the rail to the engine combustion room after receiving a signal from the ECU in the most appropriate injection timing, injection volume, injection ratio, number of injection and spray condition.
Accelerator sensor	Unlike mechanical governors, the common rail fuel injection system has no governor lever. The accelerator sensor serves as the governor lever to provide the speed command signal (voltage signal) to the ECU for engine speed control.
Engine diagnosis tool	Allows the operator to troubleshoot the cause of a problem based on detailed information regarding the problem occurring in the ECU. This tool can also be used for data maintenance tasks including programming and mapping. <i>See Troubleshooting on page 107</i>

CONTROL EQUIPMENT

The equipment in the control room makes remote control operation possible. It consists of the instrument panel, which is connected to the engine by a wire harness, and the remote control handle, which is connected by control cables to the engine control lever and marine gear.

Instrument Panel (Optional)

Equipment and Functions

The instrument panel is located in the cockpit. The following instruments enable you to start or stop the engine and to monitor its condition during operation.

B25-Type

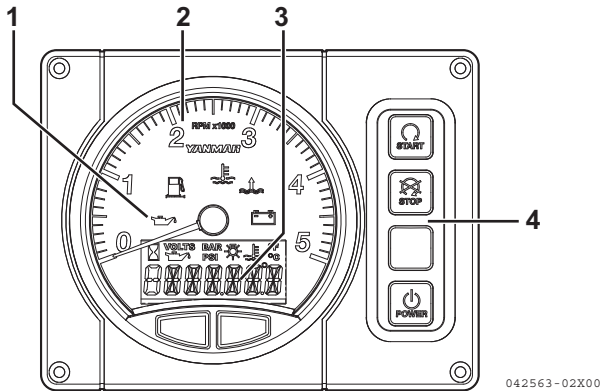

Figure 10

C35-Type

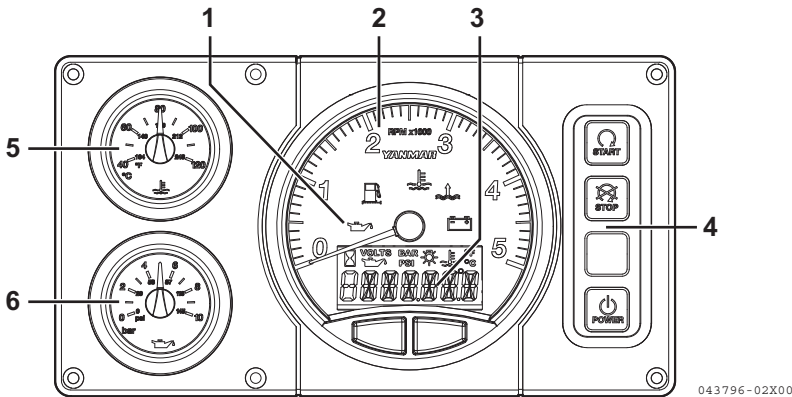

Figure 11

- 1 – Alarm lamp
- 2 – Tachometer
- 3 – LCD

- 4 – Switches (push-buttons)
- 5 – Coolant temperature gauge
- 6 – Engine oil pressure gauge

Meters

Instrument	Function
Tachometer	Shows engine rotation speed.
Hour meter	Shows number of operating hours. Can be used as a guide for periodic maintenance checks. The hour meter is located at the bottom of the tachometer.
Coolant Temperature Gauge	Shows the coolant temperature.
Engine Oil Pressure Gauge	Shows the engine oil pressure.
Panel Lights	When the power switch is pushed, the gauges will illuminate for easier viewing.

Note: The LCD on the instrument panel show hour meter, coolant temperature, display brightness, oil pressure and battery voltage. See LCD control on page 24. Other indicators in the LCD can be added by display setting. See Selection of the display setting on page 27.

Coolant temperature and oil pressure display

- B25, C35-Type panels have a digital LCD screen inside the tachometer.
- C35-Type panels have an electric gauge with a needle.

PRODUCT OVERVIEW

Instrument Panel

The formats for the instrument panel are shown below.

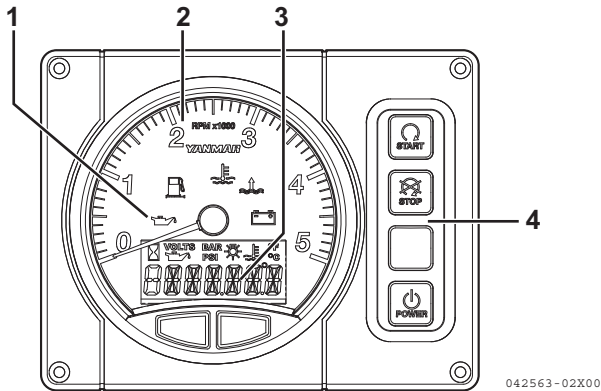

Figure 12

- 1 – Alarm lamp
- 2 – Tachometer

- 3 – LCD
- 4 – Switches (push-buttons)

Control panel switches

All switches are push-buttons.

Start switch



042564-01X00

Pushing this switch operates the starter and starts the engine.

Power switch

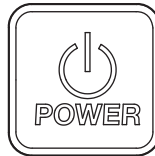

042567-01X00

Pushing this switch turns on or off the power.

Stop switch



042565-01X00

Pushing this switch stops the engine.

Indicators and Alarms (Optional)

When a sensor detects a problem during operation, the indicator on the instrument panel will light and an alarm will sound. Indicators are located on the instrument panel and the alarms are located on the back of the panel. Under normal operating conditions, the indicators are off.

Battery Low Charge Indicator



When the alternator output is too low, the indicator will light. When charging begins, the indicator will turn off.

Coolant High Temperature Indicator and Alarm



When coolant temperature reaches the maximum allowable temperature (95°C [203°F] or higher), the indicator will light and the alarm will sound. Continuing operation at temperatures exceeding the maximum limit will result in damage and seizure. Check the load and troubleshoot the cooling system.

Engine Oil Low Pressure Indicator and Alarm



When the engine oil pressure falls below normal, the oil pressure sensor will send a signal to the indicator, causing it to light and the alarm to sound. Stop operation to avoid damage to the engine. Check the oil level and troubleshoot the lubrication system.

Water in Sail Drive Seal Indicator and Alarm



When water is detected between the seals of the sail drive, the indicator will light and the alarm will sound.

Water in Fuel Filter Indicator and Alarm



When the water level in the fuel filter/water separator becomes too high, the indicator will light and the alarm will sound. Drain the water from the fuel filter/water separator. *See Draining Fuel Filter/Water Separator on page 95.*

PRODUCT OVERVIEW

LCD control

(hour meter, coolant temperature, display brightness, oil pressure, battery voltage)

You can switch (scroll) between displays by pressing the buttons on the bottom as the default setting.

- **Switching screens by pressing the right button (Pressing the left button switches the screens in the opposite direction.)**

Press the power switch.

- After 4 seconds, the LCD shows the hour meter.

Pressing the right button on the bottom of the LCD shows the temperature display. Select between Metric units (°C) and Imperial units (°F) at the "System Units screen" on the next page.

Pressing the right button again shows the LCD brightness settings.

To set the brightness of the backlight:

- 1 Press the left button continuously and the digits of the LCD start flashing.
- 2 In this condition, press the left button to increase the brightness.
- 3 Press the right button to decrease the brightness. (The brightness changes in 6 steps of 20 %.)

To set the desired brightness, do not touch the buttons for 3 seconds.

Note: Continuously pressing means holding the button for approx. 2 seconds.

Next, press the right button to show the pressure display. Select between Metric units (BAR) and Imperial units (PSI) at the "System Units screen" on the next page.

Press again to show the battery voltage. Pressing the button once more, return the display to the initial hour meter.

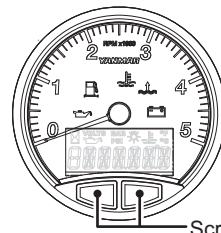

Scroll
Engine hour (>300 min⁻¹)

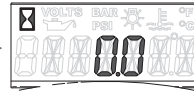

Coolant temperature

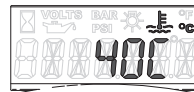

Metric

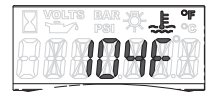

Imperial units

Backlighting Brightness

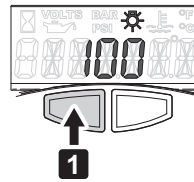

Push and hold
(display will blink when ready)

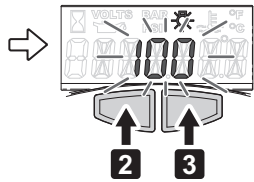

Scroll
100, 80, 60, 40, 20, 0
(value will be set after 3 seconds)

Oil pressure



Metric

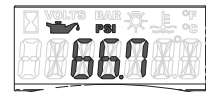

Imperial units

Battery voltage



Return to hour meter

055130-00EN01

Figure 13

**Setup screen access and control
(Setting the temperature, pressure units and others)**

Use the buttons on the bottom of the LCD display to set the instrument panel. Press the left button to switch between displays.

- 1** Press and hold both buttons until "SET UP" appears.
- 2** Press the left button to set the units for the temperature and pressure display.

Setting the temperature and pressure units

The display says "UNIT".

- 1** Next, press the right button to select Metric units (°C, BAR). The display says "METRIC".
- 2** Press the left button to switch to Imperial units (°F, PSI). The display says "ENGL".
- 3** Press the right button to select and go back to the "UNIT" screen.
- 4** Press the left button and go to the next screen "FUEL".

Confirm that the display indicates "FUEL". Pressing the right button displays the fuel tank level setting screen.

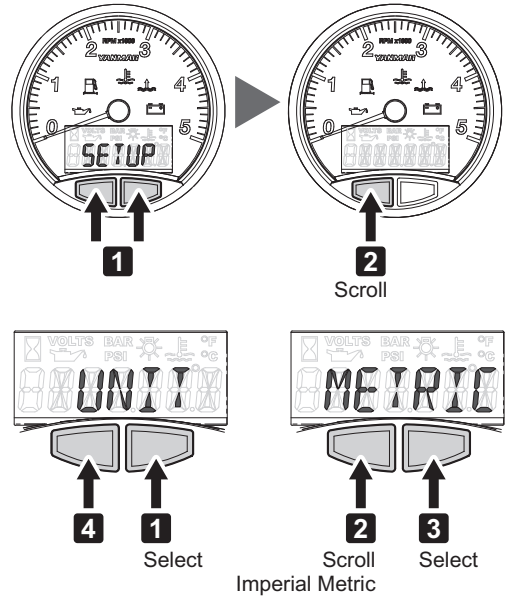

057180-00EN00

Figure 14

PRODUCT OVERVIEW

Selecting the fuel tank level gauge (Usually set at boat builder)

The display indicates "FUEL".

(You can select to the next setting by pressing the left button.)

- 1** Press the right button to select the type of the gauges.
- 2** Change the type by pressing the left button.
- 3** Press the right button to select the type.
- 4** Press the left button and go to the next screen "dISPLAY".

There are four types of fuel level gauge setting. The type of level gauge can be changed by scrolling and selecting the setting with the buttons.

Type	F3-180
	F240-3
	F70-3
	CAN

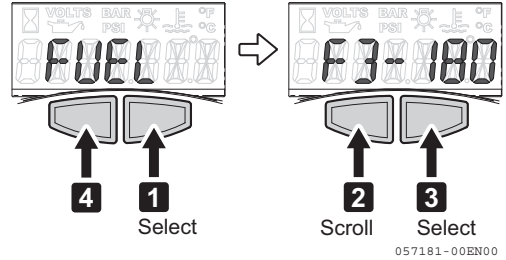

Figure 15

Selection of the display setting

The following indicators can be displayed on LCD by this setting.

TH POS	TH ON	Throttle position %
	TH OFF	
ENG Ld	Ld ON	Engine load %
	Ld OFF	
FL RT	FR ON	Fuel flow rate L/h or Gal/h
	FR OFF	
AIR PRS	AP ON	Intake air pressure Bar or PSI
	AP OFF	
FL TMP	FT ON	Fuel temperature degC or degF
	FT OFF	
RETURN		Return to dISPLAY

The display indicates "dISPLAY". You can select to the next setting by pressing the left button.

- 1 Press the right button to select the indicator.
- 2 Press the right button to display the setting screen.
- 3 Press the left button to toggle between On/Off.
- 4 Press the right button to select the setting.
- 5 Press the left button and go to the next screen "ENG Ld".

Setting of the next indicator.

Repeat the same procedure to set other indicators.

- 6 When "RETURN" is indicated on the screen, press the right button to exit the "dISPLAY" mode.
- 7 Press the right button when "EXIT" is shown on the screen to exit the setup mode.
All LCD light up for a while, then the screen returns to hour meter.

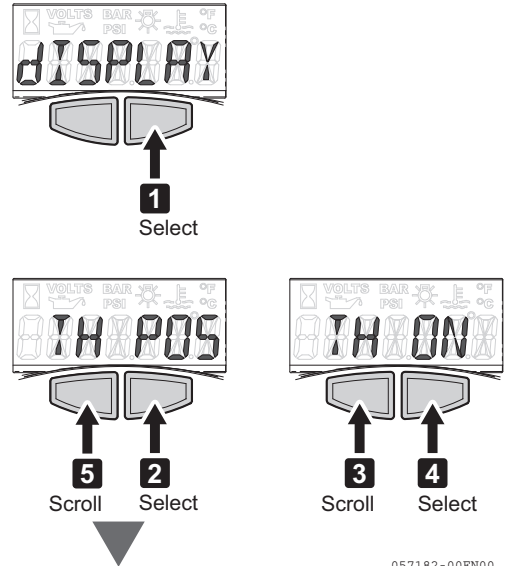

Figure 16

057182-00EN00

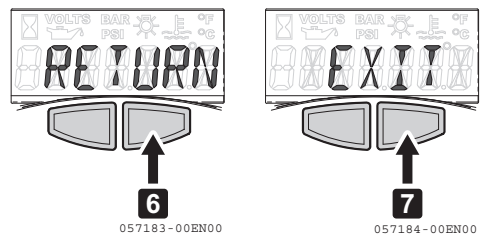
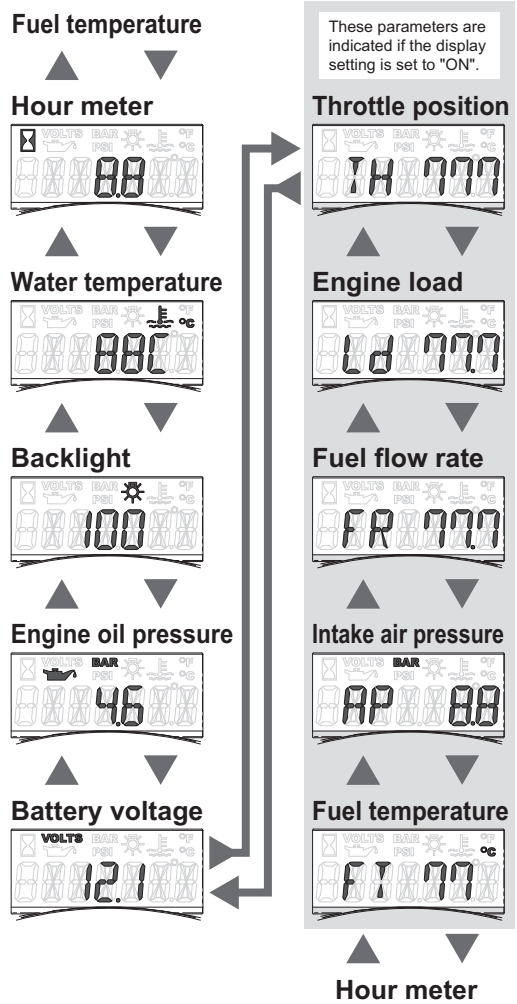

Figure 17

PRODUCT OVERVIEW

Scroll the LCD screen with the buttons.



057189-00EN00

Figure 18

Alarms

Checking the Warning Devices

Be Sure to Check the Warning Devices before Starting the Engine.

If the devices are not working properly, it is impossible to prevent any accidents arising from problems like insufficient oil and water.

NOTICE

When the warning devices are activated and normal operation is impossible, stop the engine and do not use it until the problem has been solved.

Before Engine Start

1. Turn on the battery switch.
 2. Push the power switch on.
- All alarm lamps light up for 4 seconds.
 - After 4 seconds, the hour meter is displayed.

After Engine Start

After engine start, make sure that the warning devices operate correctly and according to “After start” in the below table.

- All alarm lamps turn off. The above check tells you whether the electric circuit for the alarm lamps and alarm buzzer operate correctly. If they do not operate correctly, inspection and repair are required. Consult your dealer or distributor for repairs.

Correct operation of the warning devices				
Instrument panel (power switch)	Power ON			
	Immediately	After 2 seconds	After 4 seconds	-
	Before start			After start
Starter switch	OFF			ON
Alarm buzzer	ON (0.3s)	OFF		OFF
Charge lamp	ON	ON	OFF	OFF
Coolant temperature lamp	ON	ON	OFF	OFF
Engine lubricating oil pressure lamp	ON	ON	OFF	OFF
LCD display	Yanmar	Full display	Hour meter	

PRODUCT OVERVIEW

Accessory power output

The harness attached to the panel has a terminal where the signal that is synchronized to the panel power supply can be taken off. **(Figure 19)** (Refer to the *Wiring Diagrams on page 149.*)

The maximum current of this output terminal is 3 A (Fuse capacity). Do not use a current higher than 3 A.

For the content of the output terminal, refer to the *Wiring Diagrams on page 149.*

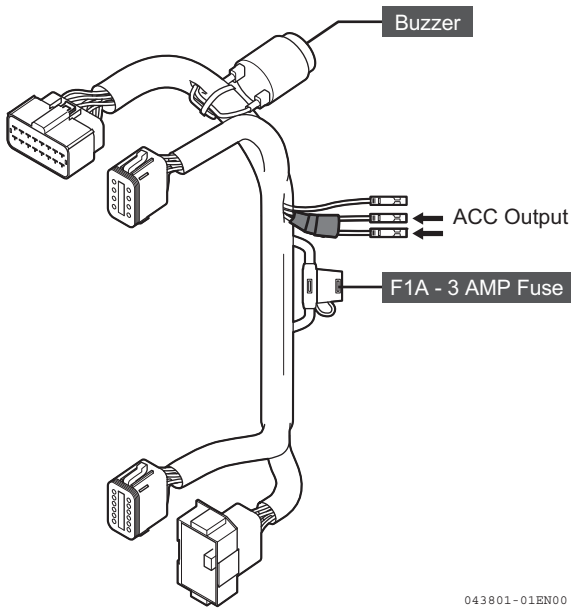

Figure 19

Single-Lever Remote Control Handle

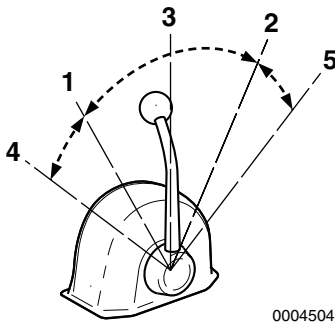

Figure 20

Note: Direction of travel will vary depending on installation location.

- 1 – Low Speed - FWD or REV**
- 2 – Low Speed - FWD or REV**
- 3 – NEUTRAL - Power to the propeller shaft is cut off and the engine idles**
- 4 – Maximum Engine Speed - FWD or REV**
- 5 – Maximum Engine Speed - FWD or REV**

A single handle-type (**Figure 20**) should be used to operate the marine gear clutch (NEUTRAL, FORWARD and REVERSE) and to control the engine speed.

The handle controls the direction of the boat (ahead or astern) and also acts as an accelerator by increasing engine speed as the lever is pushed further in FORWARD or REVERSE directions.

When the handle is pulled out (**Figure 21, (1)**), the engine speed can be controlled without engaging the clutch. The clutch remains in NEUTRAL, no load position. Turn the knob (**Figure 21, (2)**) counterclockwise to move the handle or clockwise to lock the handle.

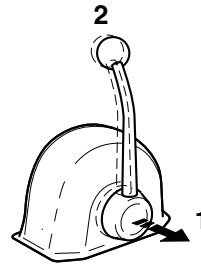

0004511

Figure 21

Note: Yanmar recommends the use of a single-lever type for the remote control system. If only a two-lever type is available in the market, reduce engine speed to 1000 min⁻¹ or less before engaging and disengaging the marine gear clutch.

VESSEL CONTROL SYSTEM (VC10)

3/4JH common rail series engine is a fully electronic control engine, which is controlled by Yanmar’s original “Vessel Control System (VC10)”.

The control equipment consists of the Switch Panel, the Display, the Drive & Helm ECU, the Control Head and the Backup Panel, which are connected by the cable harness to the engine and marine gear or Shift Actuator for remote control operation.

Note: The Yanmar Vessel Control System (VC10) was designed to operate the 3/4JH common rail series and drive system. There are many control functions and diagnostic functions that are integrated together to insure safe operation. If this system is not utilized in specific accordance with the instructions in this manual or the system is modified in any way, Yanmar will not be responsible for any warranty failures in the operation of the system or the vessel utilizing the system. Yanmar has designed the Vessel Control System (VC10) in conjunction with the 3/4JH common rail series. The system has many functions that must be configured and calibrations must be made before the vessel can be operated. Please arrange to have a Yanmar trained technician inspect the vessel prior to the vessels operation.

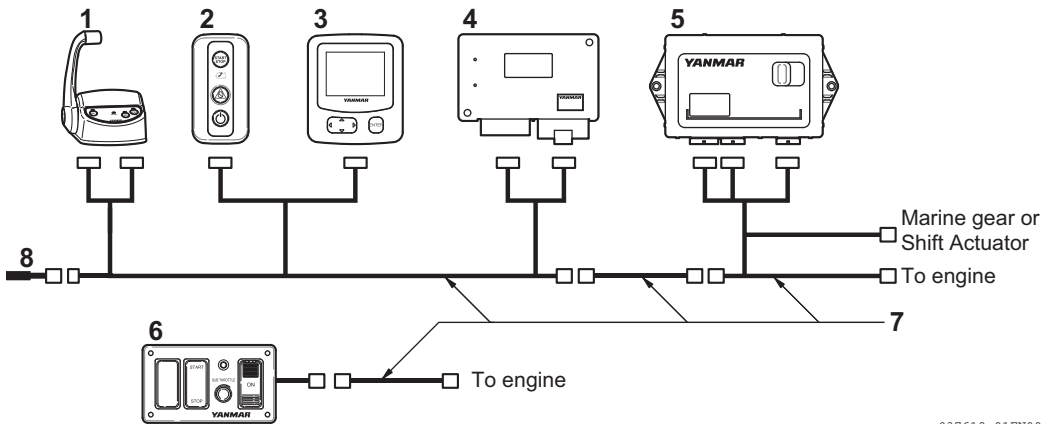

037618-01EN00

Figure 22

No.	Description
1	Shift and Throttle Control Head
2	Switch Panel (to start and stop the engine)
3	VC10 Digital Display
4	Helm ECU
5	Drive ECU
6	Backup Panel
7	Cable Harness Set
8	Adapter, Terminal

Display

The multi-function information display has the following functions.

Display Function

Runtime Engine Data Tri-Screen

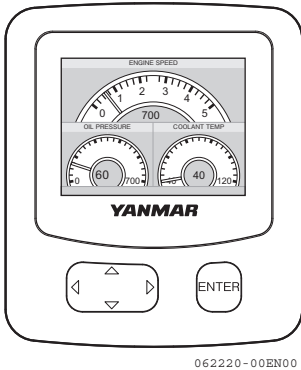

Figure 23

This screen displays real time engine data and alarm indications.

Alarm Indicators

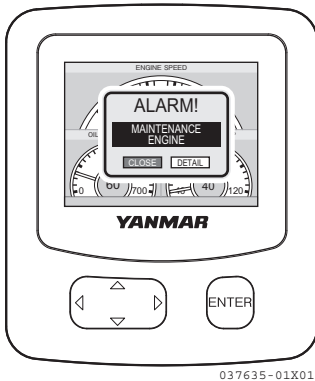

Figure 24

The alarm window appears with an audible alarm when abnormal engine activity occurs.

Note: When starting the engine, make it a rule to check that when the switch panel is pressed to the power switch, the welcome screen appears on the display and goes out. If the system does not function normally, consult your authorized Yanmar Marine dealer or distributor and ask for diagnostics.

Diag Codes Screen

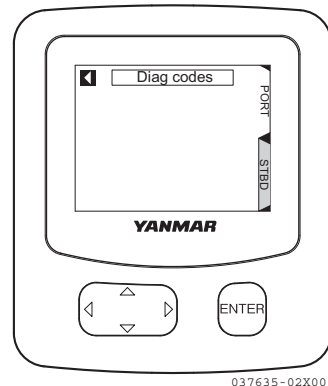

Figure 25

Alarm Indicator Functions

The alarm indicators and buzzer are activated when sensors detect an abnormality during engine operation. The alarm indicators are off during normal operation, but are activated as follows when an abnormality arises:

- The coolant temperature alarm indicator activates when the coolant gets too hot.
- The engine oil pressure alarm indicator activates when the engine oil pressure drops.
- The electric charge alarm indicator activates when there is a charging failure.

PRODUCT OVERVIEW

Operation of the Display's Buttons

Buttons

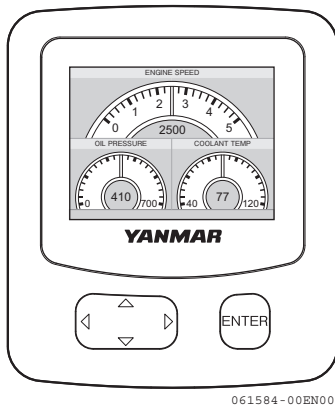

- Act on pop-up menu (MAIN MENU)
- Perform the function

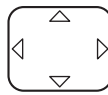

- ▲ Up Arrow moves menu selection up
- ▼ Down Arrow moves menu selection down
- ◀ Left Arrow acts on current menu item
- ▶ Right Arrow acts on current menu item

Figure 26

Hot Key List

Item	Operation	Indication
MAIN MENU	Press the [ENTER] button.	Display MAIN MENU.
MENU LAYER SKIP	Hold the ◀ button down for 1 second.	Close MENU and return to the normal screen.
ICON INFO	Press the ▼ button while the icon with a detail information indication function is displayed.	Display the related setting screen of the relevant icon. If there are multiple items, execute with the [ENTER] button after selecting with the ◀ ▶ buttons.
Adjusting Brightness	Press the ▲ button.	Display the brightness adjustment screen and adjust brightness with the ▲ ▼ buttons.
Switching Night Mode	Press the ◀ button.	Switch to the night mode indication.
Setting Complete	Hold the [ENTER] button down for 1 second while the ◻ icon is highlighted.	Close the setting screen and MENU and return to the normal indication.
Switching Monitor Display Indication	Press the ▶ button.	Switch to the monitor screen in the normal indication. Send the screen in order with the ◀ ▶ buttons. The monitor screen is fixed when there is no operation with the ◀ ▶ buttons for 5 seconds.

Switch Panel (to start and stop the engine)

The switch panel has the following functions.

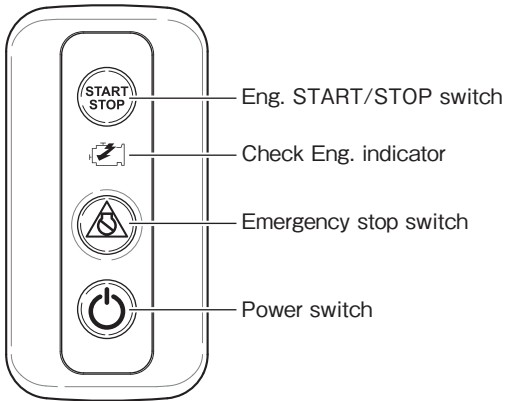

037627-00B00

Figure 27

To start and stop the engine:

Press the START/STOP switch.

Emergency Stop Switch

Use this switch only in an emergency.

NOTICE

Under normal circumstances, do not use the Emergency stop switch to stop the engine.

The engine shuts down suddenly when the Emergency stop switch is pressed. After the engine has stopped, press the Emergency stop switch to release the emergency stop.

This Page Intentionally Left Blank

BEFORE YOU OPERATE

INTRODUCTION

This section of the *Operation Manual* describes the diesel fuel, engine oil and engine coolant specifications and how to replenish them.

SAFETY PRECAUTIONS

Before performing any operations within this section, review the *Safety* section on page 3.

BEFORE YOU OPERATE

DIESEL FUEL

Diesel Fuel Specifications

WARNING

Fire and Explosion Hazard.
Diesel fuel is flammable and explosive under certain conditions.

Only use diesel fuels recommended by Yanmar for the best engine performance, to prevent engine damage and to comply with EPA warranty requirements. Only use clean diesel fuel.

Diesel fuel should comply with the following specifications. The table lists several worldwide specifications for diesel fuels.

DIESEL FUEL SPECIFICATION	LOCATION
ASTM D975 No. 2-D S15, No. 1-D S15	USA
EN590-2009	European Union
ISO 8217 DMX	International
BS 2869-A1 or A2	United Kingdom
JIS K2204 Grade No. 2	Japan

Biodiesel Fuels

Yanmar approves the use of biodiesel fuels that do not exceed a blend of 7% non-mineral oil based fuel with 93% standard diesel fuel. Such biodiesel fuels are known in the marketplace as B7 biodiesel fuels. B7 biodiesel fuel can reduce particulate matter and the emission of “greenhouse” gases compared to standard diesel fuel.

If the B7 biodiesel fuel used does not meet the approved specifications, it will cause abnormal wear of injectors, reduce the life of the engine and it may affect the warranty coverage of your engine.

B7 diesel fuels must meet certain specifications.

The biodiesel fuels must meet the minimum specifications for the country in which they are used:

- In Europe, biodiesel fuels must comply with the European Standard EN590-2009, EN14214.
- In the United States, biodiesel fuels must comply with the American Standard ASTM D-6751 Grade-S15, D7467 Grade B7-S15.

Biodiesel should be purchased only from recognized and authorized diesel fuel suppliers.

Precautions and concerns regarding the use of biofuels:

- Biodiesel fuels have a higher content of methyl-esters, which may deteriorate certain metal, rubber and plastic components of the fuel system. The customer and/or boat builder are responsible to verify the usage of biodiesel compatible components on the vessel fuel supply and return systems.
- Free water in biodiesel may result in plugging of fuel filters and increased bacterial growth.
- High viscosity at low temperatures may result in fuel delivery problems, supply pump seizures and poor injection nozzle spray atomization.
- Biodiesel may have adverse effects on some elastomers (seal materials) and may result in fuel leakage and dilution of the engine lubricating oil.

- Even biodiesel fuels that comply with a suitable standard as delivered will require additional care and attention to maintain the quality of the fuel in the equipment or other fuel tanks. It is important to maintain a supply of clean, fresh fuel. Regular flushing of the fuel system, and/or fuel storage containers, may be necessary.
- The use of biodiesel fuels that do not comply with the standards as agreed to by the diesel engine manufacturers and the diesel fuel injection equipment manufacturers, or biodiesel fuels that have degraded as per the precautions and concerns above, may affect the warranty coverage of your engine.
- Do not use Biocide.
- Lubricity: Wear mark of WS1.4 should be Max. 0.016 in. (400 μm) at HFRR test.

Additional Technical Fuel Requirements

- The fuel cetane number should be 45 or higher.
- The sulfur content must not exceed 0.5% by volume. Less than 0.05% is preferred. Especially in U.S.A. and Canada, Ultra Low sulfur fuel (≤ 15 ppm) must be used.
- Never mix kerosene, used engine oil or residual fuels with the diesel fuel.
- Water and sediment in the fuel should not exceed 0.05% by volume.
- Keep the fuel tank and fuel-handling equipment clean at all times.
- Ash content not to exceed 0.01% by volume.
- Carbon residue content not to exceed 0.35% by volume. Less than 0.1% is preferred.
- Total aromatics content should not exceed 35% by volume. Less than 30% is preferred.
- PAH (polycyclic aromatic hydrocarbons) content should be below 10% by volume.

BEFORE YOU OPERATE

Handling of Diesel Fuel

WARNING

Fire and Explosion Hazard.

- Only fill the fuel tank with diesel fuel. Filling the fuel tank with gasoline may result in a fire and will damage the engine. Never refuel with the engine running. Wipe up all spills immediately. Keep sparks, open flames or any other form of ignition (match, cigarette, static electric source) well away when refueling.
- Always put the diesel fuel container on the ground when transferring the diesel fuel from the pump to the container. Hold the hose nozzle firmly against the side of the container while filling it. This prevents static electricity buildup which could cause sparks and ignite fuel vapors.

1. Water and dust in the fuel may cause engine failure. When fuel is stored, be sure that the inside of the storage container is clean and dry, and that the fuel is stored away from dirt or rain.

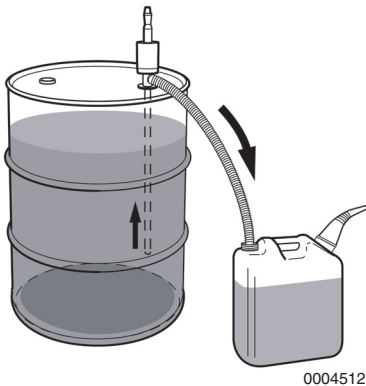

Figure 1

2. Keep the fuel container stationary for several hours to allow any dirt or water to settle to the bottom of the container. Use a pump to extract the clear, filtered fuel from the top of the container.

Fuel Tank (Optional)

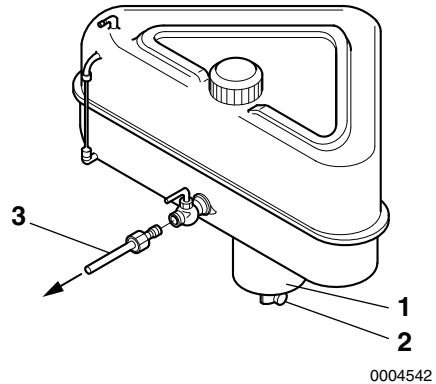

Figure 2

- 1 – Sediment Bowl
- 2 – Drain Cock
- 3 – Fuel Line to Engine

Install a drain cock (**Figure 2, (2)**) at the bottom of the fuel tank to remove water and contaminants from the sediment bowl (**Figure 2, (1)**).

The fuel outlet should be positioned 20 to 30 mm (0.79 to 1.18 in.) above the bottom of the tank so that only clean fuel is distributed to the engine.

Fuel System

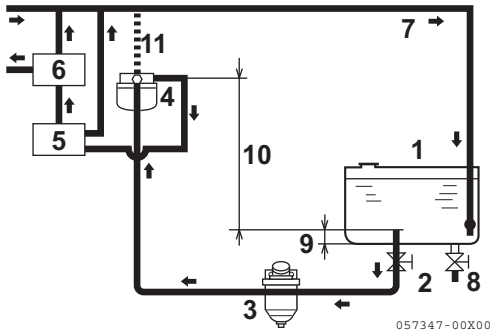

Figure 3

- 1 – Fuel Tank
- 2 – Fuel Cock
- 3 – Pre-filter (Water separator with priming pump)
- 4 – Fuel filter
- 5 – Fuel supply pump
- 6 – Common rail
- 7 – Fuel return line
- 8 – Drain cock
- 9 – Approximately 20 to 30 mm (0.79 to 1.18 in.)
- 10 – Less than 500 mm (19.7 in.)
- 11 – Orifice for air bleeding

Install the fuel line from the fuel tank to the fuel supply pump as shown in **Figure 3**. The pre-filter (fuel/water separator: Standard accessories) is installed at the intermediate section of that line.

Filling the Fuel Tank

Before filling fuel tank for the first time:

WARNING

Fire and Explosion Hazard.
Never refuel with the engine running.

Rinse fuel tank with kerosene or diesel fuel. Dispose of waste properly.

To fill the fuel tank:

WARNING

Fire and Explosion Hazard.
Operate bilge ventilation (blowers) for a minimum of 5 minutes to purge fumes from engine compartment after refueling. Never operate bilge blower while refueling. Doing so can pump explosive fumes into the engine compartment and result in an explosion.

1. Clean the area around the fuel cap.
2. Remove the fuel cap from the fuel tank.
3. Fill the tank with clean fuel free of oil and dirt.

WARNING

Fire and Explosion Hazard.
Hold the hose nozzle firmly against the filler port while filling. This prevents static electricity buildup which could cause sparks and ignite fuel vapors.

4. Stop fueling when the gauge shows the fuel tank is full.

WARNING

Fire and Explosion Hazard.
Never overfill the fuel tank.

5. Replace the fuel cap and hand-tighten. Over-tightening the fuel cap will damage it.

BEFORE YOU OPERATE

Bleeding the Fuel System

The fuel system has an automatic air bleeding device that purges air from the fuel system. No manual air bleeding is required for normal operation. Bleeding must be done if any fuel system maintenance has been performed (replacement of fuel filter, etc.) or if the engine does not start after several attempts.

The fuel system needs to be primed under certain conditions:

- Before starting the engine for the first time.
- After running out of fuel and fuel has been added to the fuel tank.
- After fuel system maintenance such as changing the fuel filter and draining the fuel filter/water separator, or replacing a fuel system component.

WARNING

Fire and Explosion Hazard!

- Diesel fuel is flammable and explosive under certain conditions.
- Failure to comply could result in death or serious injury.

Exposure Hazard.

Always wear safety glasses when bleeding the fuel system.

Bleeding the pre-filter

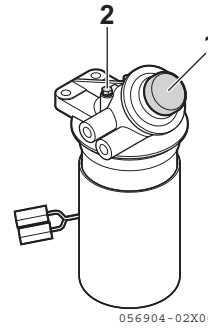

Figure 4

- 1 – Priming Pump**
2 – Air Bleed Screw

1. Check the fuel level in the fuel tank. Refill if necessary.
2. Open the fuel cock of the fuel tank.
3. Loosen the air bleed screw (**Figure 4, (2)**) two to three turns.
4. Push up and down on the priming pump (**Figure 4, (1)**) to release air out of the air bleed screw.
5. Continue pumping until a stream of fuel with no air bubbles begins to flow. (approx. 60 times.)
6. Tighten the air bleed screw.

Priming the Fuel System

Bleeding the fuel filter

An automatic bleeding device is installed on the fuel filter. Therefore an air bleed screw is not required.

1. Push up and down on the priming pump to bleed the fuel filter. (approx. 60 times)
2. When you begin to feel resistance, bleeding is complete.

NOTICE

Never use the starter motor to crank the engine in order to prime the fuel system. This may cause the starter motor to overheat and damage the coils, pinion and/or ring gear.

ENGINE OIL

Engine Oil Specifications

Using engine oil that does not meet or exceed the following guidelines or specifications may cause seizure of parts, abnormal wear and shorten engine life.

Service Categories

Use an engine oil that meets or exceeds the following guidelines and classifications:

- API Service Categories CD, CF, CF-4, CI and CI-4.
- SAE Viscosity: 10W-30, 15W-40. Engine oil 10W-30 and 15W-40 can be used throughout the year.

NOTICE

- Be sure the engine oil, engine oil storage containers and engine oil filling equipment are free of sediment or water.
 - Change the engine oil after the first 50 hours of operation and then at every 250 hours thereafter.
 - Select the oil viscosity based on the ambient temperature where the engine is being operated. See the SAE Service Grade Viscosity Chart (**Figure 5**).
 - Yanmar does not recommend the use of engine oil “additives”.
-

BEFORE YOU OPERATE

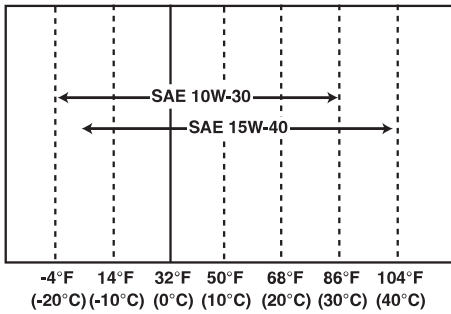

0000005

Figure 5

Handling Engine Oil

1. When handling and storing engine oil, be careful not to allow dust and water to contaminate the oil. Clean around the filler port before filling.
2. Do not mix lube oils of different types or brands. Mixing may cause the chemical characteristics of the oil to change and lubricating performance to decrease, reducing the engine's life.
3. Engine oil should be replaced at the specified intervals, regardless if the engine has been operated.

Engine Oil Viscosity

SAE 10W-30 or SAE 15W-40 are the recommended oil viscosities.

If you operate your equipment at temperatures outside the limits shown, consult your authorized Yanmar dealer or distributor for special lubricants or starting aids.

Checking the Engine Oil

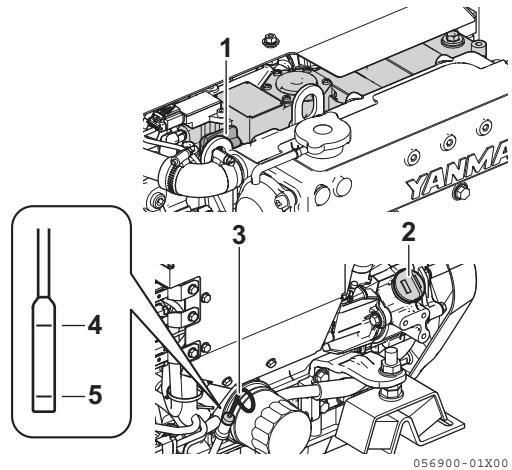

Figure 6

056900-01X00

- 1 – Engine oil filler port cap
(On the rocker arm cover)
- 2 – Engine oil filler port cap
(On the gearcase)
- 3 – Dipstick
- 4 – Upper Limit
- 5 – Lower Limit

Note: 4JH45/57 shown. Other models are similar.

1. Make sure the engine is level.
2. Remove dipstick (**Figure 6, (3)**) and wipe with clean cloth.
3. Fully reinsert dipstick.
4. Remove dipstick. The oil level should be between upper (**Figure 6, (4)**) and lower (**Figure 6, (5)**) lines on the dipstick.
5. Add oil if necessary. *See Adding Engine Oil on page 45.*
6. Fully reinsert dipstick.

Adding Engine Oil

1. Remove the yellow oil filler port cap from filler port (**Figure 6, (1) (2)**) and fill with engine oil.

NOTICE

Prevent dirt and debris from contaminating engine oil. Carefully clean the dipstick and the surrounding area before you remove the cap.

2. Fill with oil to the upper limit (**Figure 6, (4)**) on the dipstick (**Figure 6, (3)**).

NOTICE

Never overfill the engine with engine oil.

3. Insert the dipstick fully to check the level.

NOTICE

Always keep the oil level between upper and lower lines on the oil cap/dipstick.

4. Hand-tighten the filler port cap securely.

MARINE GEAR OR SAIL DRIVE OIL

Marine Gear Oil Specifications

Use marine gear oil that meets or exceeds the following guidelines and classifications:

KM35P, KM35A, KM35A2, KM4A1, KM4A2, KMH4A, KMH50V:

- API Service Categories CD or higher
- SAE Viscosity #20 or #30

ZF30M, ZF25A, ZF25:

- ATF (Automatic Transmission Fluid)

Sail Drive Oil Specifications

Refer to the *Operation Manual* of the sail drive for the procedure to fill or replace the sail drive oil.

3JH40, 4JH45, 4JH57 (SD60-5)

4JH80 (SD60-4):

- API Service Categories CD or higher
- SAE Viscosity 15W-40

BEFORE YOU OPERATE

Checking Marine Gear Oil

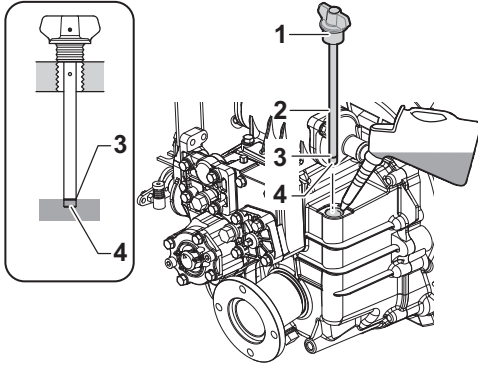

Figure 7

- 1 – Filler cap
- 2 – Dipstick
(Filler cap combined type)
- 3 – Upper Limit
- 4 – Lower Limit (Dipstick end)

Note: 4JH110 with KMH4A marine gear shown.

1. Make sure engine is level.
2. Remove the filler cap (**Figure 7, (1)**) at the top of the housing.
3. Remove dipstick (**Figure 7, (2)**) and wipe with clean cloth.
4. Re- insert the dipstick without screw in. See the illustration (**Figure 7**).
5. Remove dipstick. The oil level should be between upper (**Figure 7, (3)**) and lower (**Figure 7, (4)**) lines on the dipstick.
6. Screw in the dipstick.

Adding Marine Gear Oil

1. Make sure the engine is level.
2. Remove the filler cap (**Figure 7, (1)**) at the top of the housing.
3. Fill with oil to the upper limit on the dipstick (**Figure 7, (3)**). See *Marine Gear Oil Specifications* on page 45.

NOTICE

Never overfill the marine gear with oil.

4. Screw in the dipstick.
5. Tighten the filler port cap by hand.

Checking and Adding Sail Drive Oil

Refer to the operation manual for SD60 for the procedure to check and fill the sail drive oil.

ENGINE COOLANT

Engine Coolant Specifications

Note: In the U.S., LLC is required for the warranty to be valid.

- Texaco Long Life Coolant (LLC), both standard and premixed, product code 7997 and 7998
- Havoline Extended Life Antifreeze/Coolant, product code 7994

Following the manufacturer's recommendations, use a proper LLC which will not have any adverse effects on the materials (cast iron, aluminum, copper, etc.) of the engine's cooling system.

Always use the mixing ratios specified by the antifreeze manufacturer for the temperature range.

Coolant (Closed Cooling System)

NOTICE

Always add LLC to soft water especially when operating in cold weather. Never use hard water. Water should be clean and free from sludge or particles. Without LLC, cooling performance will decrease due to scale and rust in the coolant system. Water alone may freeze and form ice; it expands approximately 9% in volume. Use the proper amount of coolant concentrate for the ambient temperature as specified by the LLC manufacturer. LLC concentration should be a minimum of 30% to a maximum of 60%. Too much LLC will decrease the cooling efficiency. Excessive use of antifreeze also lowers the cooling efficiency of the engine. Never mix different types or brands of LLC, as a harmful sludge may form. Mixing different brands of antifreeze may cause chemical reactions, and may make the antifreeze useless or cause engine problems.

BEFORE YOU OPERATE

Checking and Adding Coolant

3JH40

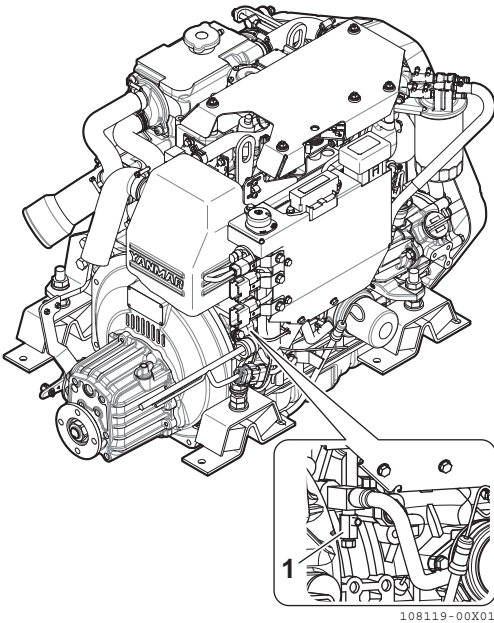

Figure 8

**1 – Coolant drain cock
(Cylinderblock)**

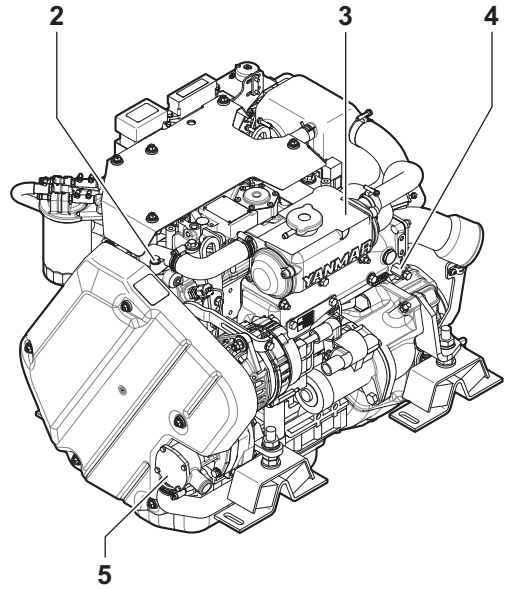

Figure 9

**2 – Coolant pump
3 – Coolant tank (Heat exchanger)
4 – Coolant drain cock
(Coolant tank/Heat exchanger)
5 – Seawater pump
(Drain from pump cover)**

4JH45, 4JH57

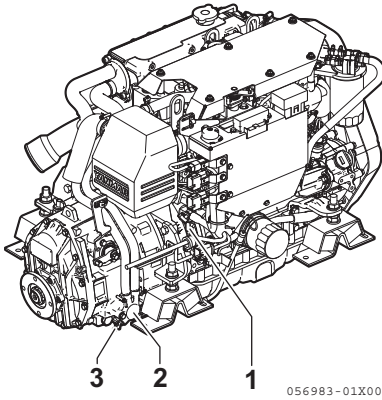

Figure 10

- 1 – Coolant drain cock
(Cylinderblock)**
- 2 – Marine gear oil cooler (KM4A1)**
- 3 – Seawater drain cock
(Marine gear oil cooler)**

4JH80, 4JH110

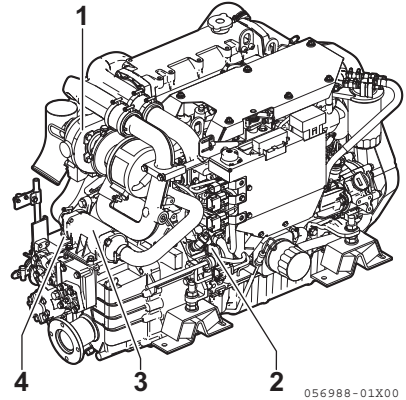

Figure 12

- 1 – Turbocharger**
- 2 – Coolant drain cock
(Cylinderblock)**
- 3 – Marine gear oil cooler (KMH4A)**
- 4 – Seawater drain cock
(Marine gear oil cooler)**

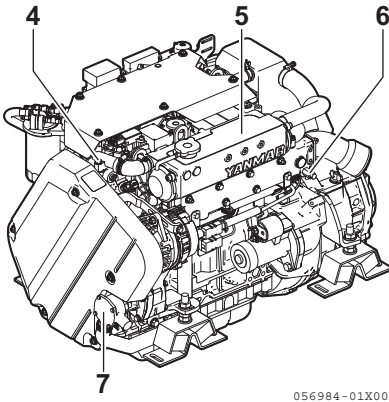

Figure 11

- 4 – Coolant pump**
- 5 – Coolant tank (Heat exchanger)**
- 6 – Coolant drain cock
(Coolant tank/Heat exchanger)**
- 7 – Seawater pump
(Drain from pump cover)**

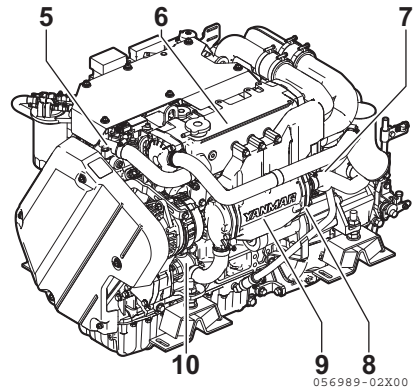

Figure 13

- 5 – Coolant pump**
- 6 – Coolant tank (Heat exchanger)**
- 7 – Coolant drain cock (Coolant
tank/Heat exchanger)**
- 8 – Seawater drain cock (Air cooler)**
- 9 – Air cooler**
- 10 – Seawater pump
(Drain from pump cover)**

BEFORE YOU OPERATE

1. Ensure all drain cocks are closed.

Note: The drain cocks are opened before shipping from the factory. Marine gear ZF25A does not have a drain cock on the marine gear cooler.

2. Loosen the filler cap of coolant tank to relieve the pressure, then remove the filler cap.

⚠ WARNING

Burn Hazard.

Never remove the coolant filler cap if the engine is hot. Steam and hot engine coolant will spray out and seriously burn you. Allow the engine to cool down before you attempt to remove the cap.

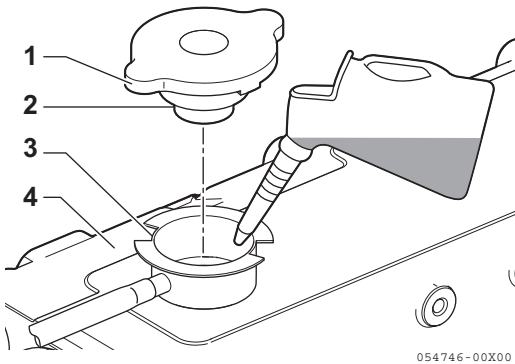

Figure 14

- 1 – Filler Cap Tabs
- 2 – Coolant Filler Cap
- 3 – Filler Port Notches
- 4 – Coolant Tank

3. Pour coolant slowly into coolant tank (Figure 14, (4)) to avoid air bubbles. Fill until coolant overflows from the filler port.

NOTICE

Never pour cold coolant into a hot engine.

4. Align filler cap tabs (Figure 14, (1)) with filler port notches (Figure 14, (3)) and tighten filler cap (Figure 14, (2)) firmly.

NOTICE

Always tighten coolant tank cap securely after checking coolant tank. Steam can spray out during engine operation if the cap is loose.

Note: The coolant level rises in the reservoir during operation. After stopping the engine, the coolant will cool down and the extra coolant will return to coolant tank.

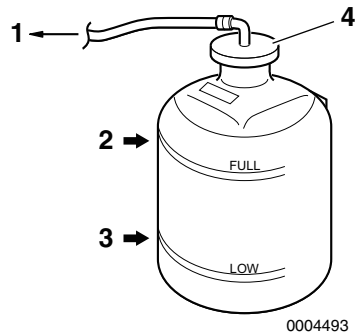

Figure 15

5. Check the coolant level in the reservoir. The level should be at the FULL mark (Figure 15, (2)). Add coolant if necessary.

NOTICE

Never pour cold coolant into a hot engine.

6. Remove reservoir cap (**Figure 15, (4)**) to add coolant if necessary. Do not add water.
7. Install filler cap and tighten it firmly. Failure to do so will cause water leakage.

Reservoir Capacity
0.8 L (0.85 qt)

8. Check the rubber hose (**Figure 15, (1)**) connecting the reservoir to coolant tank/heat exchanger. Replace if damaged.

Note: If the coolant runs low too often or the coolant level in coolant tank drops without any change in the level in the reservoir, there may be water or air leaks in the cooling system. Consult authorized Yanmar dealer or distributor.

This Page Intentionally Left Blank

ENGINE OPERATION

INTRODUCTION

This section of the *Operation Manual* describes the procedures for starting the engine, checking engine performance during operation and shutting down the engine.

SAFETY PRECAUTIONS

Before performing any operations within this section, review the *Safety* section on page 3.

WARNING

Fire and Explosion Hazard



Never jump-start the engine. Sparks caused by shorting the battery to the starter terminals may cause a fire or explosion.

Only use the start switch on the instrument panel to start the engine.

Sudden Movement Hazard

Be sure the boat is in open water away from other boats, docks or other obstructions before increasing engine speed. Avoid unexpected equipment movement. Shift the marine gear into the NEUTRAL position any time the engine is at idle.

To prevent accidental equipment movement, never start the engine in gear.

Sever Hazard



Keep children and pets away while the engine is operating.

NOTICE

If any indicator illuminates during engine operation, stop the engine immediately. Determine the cause and repair the problem before you continue to operate the engine.

If the vessel is equipped with a water lift (water lock) muffler, excessive cranking could cause seawater to enter the cylinders and damage the engine. If the engine does not start after cranking for 10 seconds, close the thru-hull water intake valve to avoid filling the muffler with water. Crank for 10 seconds at a time until the engine starts. When the engine does start, stop the engine immediately and turn off the switch.

Be sure to re-open the seacock and restart the engine. Operate the engine normally.

Observe the following environmental operating conditions to maintain engine performance and avoid premature engine wear:

- Avoid operating in extremely dusty conditions.
- Avoid operating in the presence of chemical gases or fumes.
- Never run the engine if the ambient temperature is above +40°C (+104°F) or below -16°C (+5°F).
- If the ambient temperature exceeds +40°C (+104°F), the engine may overheat and cause the engine oil to break down.

NOTICE

- If the ambient temperature is below -16°C ($+5^{\circ}\text{F}$), rubber components such as gaskets and seals will harden causing premature engine wear and damage.
- Consult your authorized Yanmar Marine engine dealer or distributor if the engine will be operated outside of this standard temperature range.

Never engage the starter motor while the engine is running. Damage to the starter motor pinion and/or ring gear will result.

OPERATION (B25,C35-TYPE INSTRUMENT PANEL)**Starting the Engine**

1. Open the seacock (if equipped).
2. Open the fuel tank cock.
3. Put remote control handle in NEUTRAL.

Note: Safety equipment should make it impossible to start the engine in any other position than NEUTRAL.

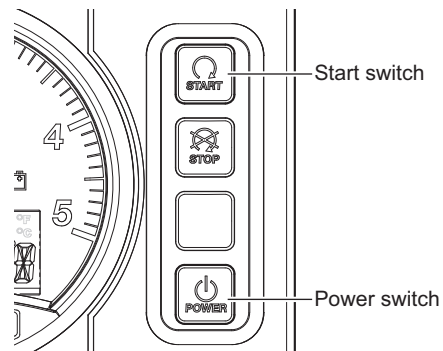

042590-02EN00

Figure 1

4. Turn on the battery switch for engine and engine control system.
Do not turn off the battery switch during engine operation. Also, turn it off when the engine does not operate.
5. If all alarm lamps operate when you turn on the power switch on the instrument panel, the warning devices operate correctly.
6. Pushing the start switch turns on the engine. Release the switch after the engine starts.

If the Engine Fails to Start

Before pushing the start switch again, be sure to confirm that the engine has stopped completely. If an attempt to restart is made while the engine is running, the pinion gear of the starter motor will be damaged.

NOTICE

Never hold for longer than 15 seconds or the starter motor will overheat.

Never attempt to restart the engine if the engine has not stopped completely. Pinion gear and starter motor damage will occur.

Note: Push and hold the start switch for a maximum of 15 seconds. If the engine does not start the first time, wait for about 15 seconds before trying again.

NOTICE

If the vessel is equipped with a water lift (water lock) muffler, excessive cranking could cause seawater to enter the cylinders and damage the engine. If the engine does not start after cranking for 15 seconds, close the thru-hull water intake valve to avoid filling the muffler with water. Crank for 10 seconds at a time until the engine starts. When the engine does start, stop the engine immediately and turn off the power switch. Be sure to re-open the seacock and restart the engine. Operate the engine normally.

Air Bleeding the Fuel System after Starting Failure

If the engine does not start after several attempts, there may be air in the fuel system. If air is in the fuel system, fuel cannot reach the fuel supply pump. Bleed the air out of the system. *See Bleeding the Fuel System on page 42.*

Starting at Low Temperatures

Comply with local environmental requirements. Do not use starting aids.

NOTICE

Never use an engine starting aid such as ether. Engine damage will result.

To limit white smoke, run the engine at low speed and under moderate load until the engine reaches normal operating temperature. A light load on a cold engine provides better combustion and faster engine warm-up than no load.

Avoid running the engine at idling speed any longer than necessary.

After the Engine has Started

After the engine has started, check the following items at a low engine speed:

1. Check that the gauges, indicators and alarm are normal.
 - Normal coolant operating temperature is approximately 76° to 90°C (169° to 194°F).
 - Normal oil pressure at 3000 min⁻¹ is 0.28 to 0.54 MPa (41 to 78 psi).
2. Check for water, fuel or oil leakage from the engine.
3. Check that the smoke color, engine vibration and sound are normal.
4. When there are no problems, keep the engine at low speed with the boat still stopped to distribute engine oil to all parts of the engine.
5. Check that sufficient seawater is discharged from the seawater outlet. Operation with inadequate seawater discharge will damage the impeller of the seawater pump. If seawater discharge is too low, stop the engine immediately. Identify the cause and repair.

NOTICE

The engine will seize if it is operated when seawater discharge is too small or if load is applied without any warming up operation.

For troubleshooting assistance, see *Troubleshooting After Starting* on page 107 or *Troubleshooting Chart* on page 109. If necessary, consult authorized Yanmar dealer or distributor.

REMOTE CONTROL HANDLE OPERATION

Acceleration and Deceleration

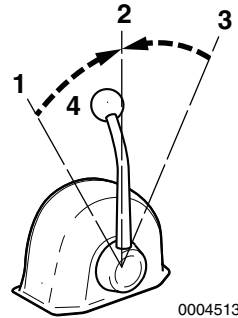

Figure 2

- 1 – FORWARD or REVERSE
- 2 – NEUTRAL
- 3 – REVERSE or FORWARD
- 4 – Throttle Handle/Shifting Handle

Note: Direction of travel will vary depending on installation location.

Use the throttle handle (**Figure 2, (4)**) to control acceleration and deceleration. Move the handle slowly.

Shifting the Engine

⚠ WARNING

Sudden Movement Hazard. The boat will start to move when the marine gear is engaged:

- Ensure the boat is clear of all obstacles forward and aft.
- Quickly shift to the FORWARD position then back to the NEUTRAL position.
- Observe whether the boat moves in the direction you expect.

NOTICE

Shifting the marine gear while operating at high speed or not pushing the handle fully into position (partial engagement) will result in damage to marine gear parts and abnormal wear.

1. Before using the marine gear, be sure to move the throttle handle to a low idle position (less than 1000 min⁻¹). Move the throttle handle slowly to a higher speed position after completing marine gear engagement.
2. When moving the handle between FORWARD (**Figure 2, (1 or 3)**) and REVERSE (**Figure 2, (3 or 1)**), bring the handle to NEUTRAL (**Figure 2, (2)**) and pause before slowly shifting to the desired position. Never shift abruptly from FORWARD to REVERSE or vice versa.

NOTICE

- Never shift the marine gear at high engine speed. During normal operation, the marine gear should only be shifted with the engine at idle.
- When sailing, set the remote control handle in NEUTRAL. Not doing so WILL introduce slippage or any damage and void your warranty.

In case that the marine gear can not be shifted by remote control handle for some reason such as broken cable, remove the cable from shift lever on the marine gear and shift manually by turning the lever.

Switching to Trolling (KMH4A Only)

Use the trolling handle to begin trolling. When changing from FORWARD or REVERSE to trolling, the speed of the propeller revolution will be reduced to a minimum.

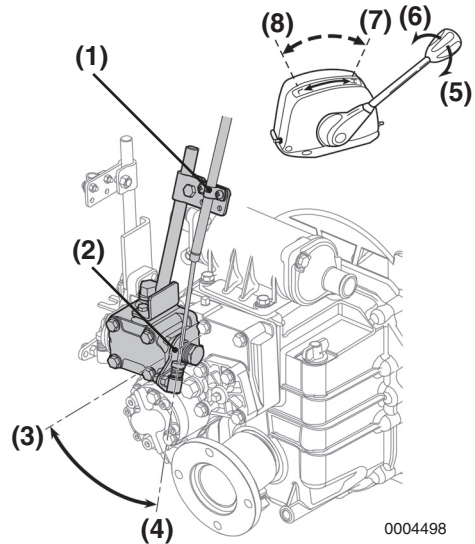

Figure 3

- 1 – Cable Fitting**
- 2 – Trolling Lever**
- 3 – Low Speed (trolling)**
- 4 – High Speed**
- 5 – Loosen**
- 6 – Tighten**
- 7 – Normal Operation (high speed)**
- 8 – Trolling (low speed)**

1. Operation continues at low engine speed of 1000 min⁻¹ or less.
2. Reduce the speed by moving the trolling handle from high speed (H) (**Figure 3, (4)**) to low speed (L) (**Figure 3, (3)**). Adjust the speed to the desired rate and secure the trolling handle in place.

3. Before returning to normal operation, be sure to put the trolling handle in high-speed (H) position.
4. Increase engine speed and continue normal operation.

CAUTIONS DURING OPERATION

NOTICE

Engine trouble can arise if the engine is operated for a long time under overloaded conditions with the control handle in the full throttle position (maximum engine speed position), exceeding the continuous rated output engine speed. Operate the engine at about 100 min^{-1} lower than the full throttle engine speed.

Note: If the engine is in the first 50 hours of operation, see New Engine Break-In on page 12 .

Always be on the lookout for problems during engine operation.

Pay particular attention to the following:

- Is sufficient seawater being discharged from the exhaust and seawater outlet pipe?

If the discharge is small, stop the engine immediately; identify the cause and repair.

- Is the smoke color normal?

The continuous emission of black exhaust smoke indicates engine overloading. This shortens the engines life and should be avoided.

- Are there abnormal vibrations or noise?

NOTICE

Excessive vibration may cause damage to the engine, marine gear, hull and onboard equipment. In addition, it causes able passenger and crew discomfort.

Depending on the hull structure, engine and hull resonance may suddenly become great at a certain engine speed range, causing heavy vibrations. Avoid operation in this speed range. If you hear any abnormal sounds, stop the engine and inspect.

- Alarm buzzer sounds during operation.

NOTICE

If any alarm indicator with audible alarm sound appears on the display during engine operation, stop the engine immediately. Determine the cause and repair the problem before you continue to operate the engine.

- Is there water, oil or fuel leakage, or are there any loose bolts?

Check the engine room periodically for any problems.

- Is there sufficient diesel fuel in the diesel fuel tank?

Replenish diesel fuel before leaving the dock to avoid running out of fuel during operation.

- When operating the engine at low speed for long periods of time, race the engine once every 2 hours.

NOTICE

Racing the engine: With the gear in NEUTRAL, accelerate from the low-speed position to the high-speed position and repeat this process about five times. This is done to clean out carbon from the cylinders and the fuel injection valve. Neglecting to race the engine will result in poor smoke color and reduce engine performance.

- If possible, periodically operate the engine at near maximum engine speed while underway. This will generate higher exhaust temperatures, which will help clean out hard carbon deposits, maintaining engine performance and prolonging the life of the engine.

NOTICE

Never turn off the battery switch (if equipped) or short the battery cables during operation. Damage to the electric system will result.

SHUTTING DOWN THE ENGINE

Normal Shutdown

1. Reduce engine speed to low idle and put remote control handle in NEUTRAL.
2. Accelerate from low speed to high speed and repeat five times. This will clean out the carbon from the cylinders and the fuel injection nozzles.
3. Allow engine to run at low speed (approximately 1000 min⁻¹) without load for 5 minutes.

NOTICE

For maximum engine life, Yanmar recommends that when shutting the engine down, you allow the engine to idle, without load, for 5 minutes. This will allow the engine components that operate at high temperatures, such as the turbocharger (if equipped) and exhaust system, to cool slightly before the engine itself is shut down.

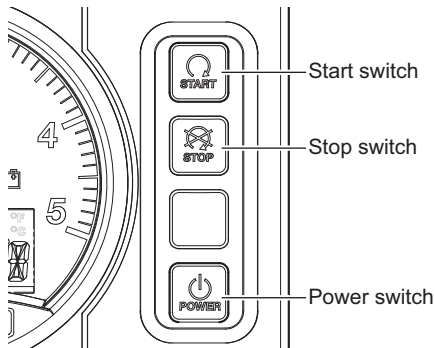

042590-02EN01

Figure 4

4. Push and hold the stop switch. After the engine has stopped, push the power switch off.

NOTICE

Continue to hold the stop switch in until the engine is completely stopped. If the switch is released before the engine has completely stopped, it may restart. If the engine does not shut down, see *Engine Auxiliary Stop Switch on page 62 and 63.*

5. Wait 6 seconds or more before turning the battery switch off for secure system settle down.

NOTICE

- Do not turn the battery switch off before turning the power switch off or immediately after turning off the power switch.
- Turning the battery switch off before secure system settle down may cause alarm to be set at the next activation by turning on the power switch. In an emergency situation, you can start the engine even if the alarm is set. In order to release above alarm, turn off the power switch and wait 6 seconds before turning the power switch on again.

6. Turn off the battery switch (if equipped).
7. Close the fuel cock.

ENGINE OPERATION

8. Close the seacock (if equipped).

NOTICE

- Be sure to close the seacock. Neglecting to close the seacock could allow water to leak into the boat and may cause it to sink.
- If seawater is left inside the engine, it may freeze and damage parts of the cooling system when the ambient temperature is below 0°C (32°F).

Engine Auxiliary Stop Switch

NOTICE

Never use the auxiliary stop switch for a normal engine shutdown. Use this switch only when stopping the engine suddenly in an emergency.

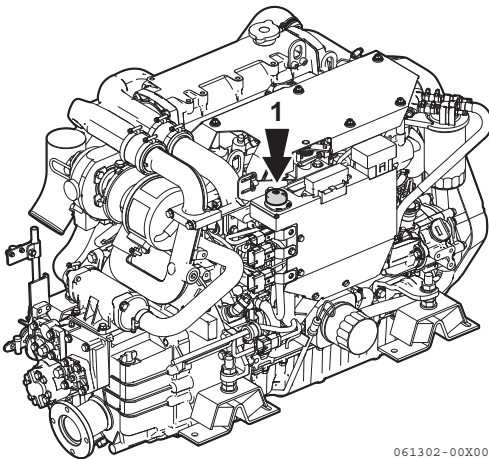

Figure 5

061302-00X00

1. Pressing the Auxiliary Stop switch on the ECU cover will stop the engine immediately.
2. "AUX STP" will be shown on the LCD of the instrument panel.
3. After the engine has stopped, release the switch by pressing and turning it to the RUN position.

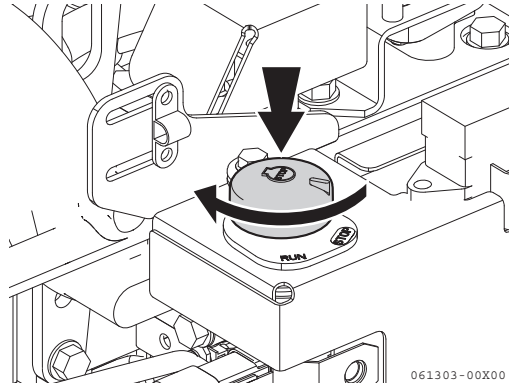

Figure 6

061303-00X00

Auxiliary Stop Switch
(Option: It is recommended that this switch is installed in an easily accessible location.)

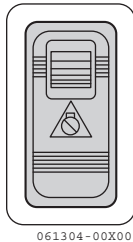

Figure 7

1. Pressing the upper part of the Auxiliary Stop switch will stop the engine immediately.
2. "AUX STP" will be shown on the LCD of the instrument panel.
3. After the engine has stopped, push the bottom part of the switch to release it.

Note: The engine cannot be started while the Auxiliary Stop switch is pressed. (Auxiliary Stop mode not canceled)

NOTICE

- In case of emergency, turning off the battery switch for the engine control unit can also stop the engine immediately.
- You can restart the engine but an alarm may be set up when the power switch is turned on. Unless you are in an emergency situation, in order to release above alarm, turn off the power switch and wait 6 seconds before turning the power switch on again.

CHECKING THE ENGINE AFTER OPERATION

- Check that the power switch is off and that the battery switch (if equipped) is turned to off.
- Fill the fuel tank. *See Filling the Fuel Tank on page 41.*
- Close seawater cock(s).
- If there is a risk of freezing, check that the cooling system contains enough coolant. *See Engine Coolant Specifications on page 47.*
- If there is a risk of freezing, drain the seawater system. *See Drain Seawater Cooling System on page 120.*
- At temperatures below 0°C (32°F), drain seawater system and connect the engine heater (if equipped).

OPERATION (VC10: VESSEL CONTROL SYSTEM)

Starting the Engine

1. Open the seacock (if equipped).
2. Open the fuel tank cock.
3. Turn the battery switch on for engine and engine control system.
4. Press the Power switch on the switch panel of the selected station (**Figure 8, (1)**).
 - The switch panel lamp will come on, and the control head (**Figure 9**) “SEL” lamp (**Figure 10**) will come on or flash.
 - To use the Engine START/STOP switch, be sure to turn the Power switch ON.

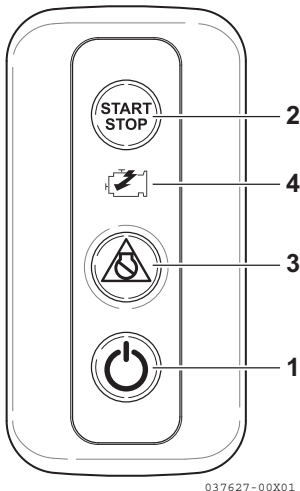

Figure 8

5. If the “Sys on by ID” has been set, enter the password into the display.
6. Press the control head “SEL” switch.
 - Wait until the display shows the engine data. The display is shown.

7. If the “Start by ID” has been set, enter the password into the display.
 - The “Start by ID” has been set, the engine can be started in 10 seconds after entering the password into the display.
8. Move the remote control handle to the N (Neutral) position.

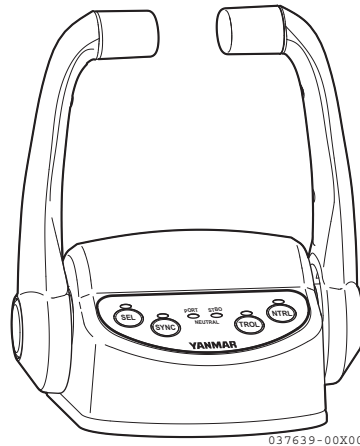

Figure 9

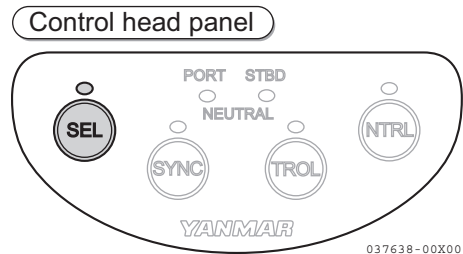
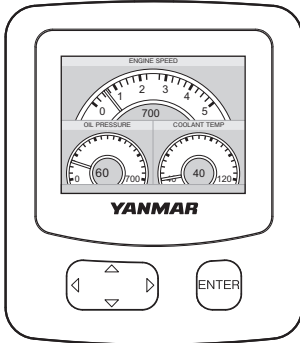

Figure 10

9. Press the Engine START/STOP switch (**Figure 8, (2)**) and power on the starter.
 - When the engine starts, the VC10 display will show the screen with engine conditions (**Figure 11**).



062220-00EN00

Figure 11

Note:

1. Concerning the control head “SEL” lamp.
For Multi-Station: the “SEL” lamp will flash and for Single Station: the “SEL” lamp will come on.
2. Pressing the Engine START/STOP switch when the “SEL” lamp is flashing allows the station to be selected as the engine is started.
3. The engine will not start or stop if the Power switch is OFF. The Power switch must be ON at all times when the engine is running.
4. Do not press the engine START/STOP switch except for stopping the engine.

ENGINE OPERATION

Vessel Control System (VC10) has the following functions, which can be set in the Utility screen of MAIN MENU in the Digital Display. For more details, refer to the Vessel Control System Installation Manual.

Station Protect

It is a function to prevent the operation from the other stations while steering.

- Select “YES” to enable “Station protect”. The display and control head of that station can no longer be operated.
- Select “NO” or turn off the system power to disable “Station protect”.

Sys on by ID, Start by ID

It is a function to check ID for the purpose of anti-theft.

- If you select “YES” in “Sys on by ID”, it is necessary to enter the Owner ID on the display when turning on the system power. If you select “YES” in “Start by ID”, it is necessary to enter the owner ID on the display at engine start.
- The initial ID is “00000” and it can be changed with the below “Owner ID change” function.
- Even when the system power is turned off, the selected “Sys on by ID” and “Start by ID” cannot be disabled and it is required to enter the Owner ID at each time.
- After entering the ID and verification, if you don’t operate for 10 seconds, the entry becomes invalid and it is required to enter the Owner ID again.

Owner ID Change

The ID used in “Sys on by ID” and “Start by ID” can be set and changed as follows.

- If you select “Owner ID change”, the ID verification screen is displayed and you are asked to enter the current ID (Default: “00000”).
- If you enter the wrong ID 5 times, the ID is locked and you are no longer able to make an input. The lock can be released by turning off the system power.
- ID can be changed to any 5 digit number from 00000 to 99999.
- Select the number from 0 to 9 with the ▲ ▼ buttons. The fixed number is displayed by an asterisk when you press the ► button and the next digit is highlighted.
- Press the [ENTER] button after highlighting it with the ► button when all 5 digits are entered and the new ID becomes valid.

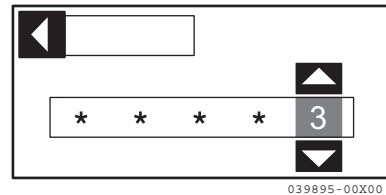

Figure 12

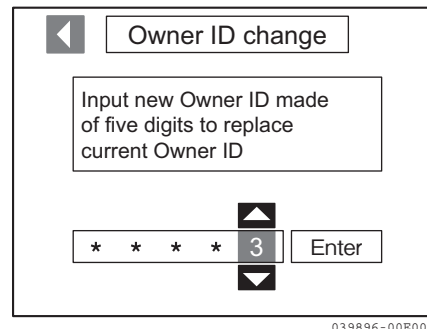

Figure 13

If the Engine Fails to Start

Before pressing the Start switch again, confirm that the engine has stopped completely. If the starter motor is operated before the engine has completely stopped, the starter motor pinion gear will be damaged.

NOTICE

Never hold for longer than 15 seconds or the starter motor will overheat.

Never attempt to restart the engine if the engine has not stopped completely. Pinion gear and starter motor damage will occur.

Note: Push and hold the start switch for a maximum of 15 seconds. If the engine does not start the first time, wait for about 15 seconds before trying again.

NOTICE

If the vessel is equipped with a water lift (water lock) muffler, excessive cranking could cause seawater to enter the cylinders and damage the engine. If the engine does not start after cranking for 15 seconds, close the thru-hull water intake valve to avoid filling the muffler with water. Crank for 10 seconds at a time until the engine starts. When the engine does start, stop the engine immediately and turn off the power switch. Be sure to re-open the seacock and restart the engine. Operate the engine normally.

Air Bleeding the Fuel System after Starting Failure

If the engine does not start after several attempts, there may be air in the fuel system. If air is in the fuel system, fuel cannot reach the fuel supply pump. Bleed the air out of the system. *See Bleeding the Fuel System on page 42.*

Starting at Low Temperatures

Comply with local environmental requirements. Do not use starting aids.

NOTICE

Never use an engine starting aid such as ether. Engine damage will result.

To limit white smoke, run the engine at low speed and under moderate load until the engine reaches normal operating temperature. A light load on a cold engine provides better combustion and faster engine warm-up than no load.

Avoid running the engine at idling speed any longer than necessary.

After the Engine has Started

After the engine has started, check the following items at a low engine speed:

1. Check that the gauges, indicators and alarm are normal.
 - Normal coolant operating temperature is approximately 76° to 90°C (169° to 194°F).
 - Normal oil pressure at 3000 min⁻¹ is 0.28 to 0.54 MPa (41 to 78 psi).
2. Check for water, fuel or oil leakage from the engine.
3. Check that the smoke color, engine vibration and sound are normal.

- When there are no problems, keep the engine at low speed with the boat still stopped to distribute engine oil to all parts of the engine.
- Check that sufficient seawater is discharged from the seawater outlet. Operation with inadequate seawater discharge will damage the impeller of the seawater pump. If seawater discharge is too low, stop the engine immediately. Identify the cause and repair.

NOTICE

The engine will seize if it is operated when seawater discharge is too small or if load is applied without any warming up operation.

WARM UP MODE (SHIFT DISCONNECT)

- Move the remote control handle to the N (Neutral) position. (The NEUTRAL lamp will come on)
- Press the "NTRL" switch of the selected station control head.
- The NEUTRAL lamp will come on, and the NEUTRAL lamp will flash.
- Move the remote control handle. The engine speed can be controlled while the gear shift is in neutral.
- Move the remote control handle to the N (Neutral) position, press the "NTRL" switch and cancel warm up mode.

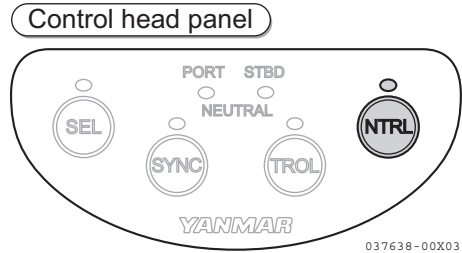

Figure 14

THROTTLE AND SHIFT CONTROL

⚠ WARNING

Sudden Movement Hazard

The boat will start to move when the marine gear is engaged:

- Ensure the boat is clear of all obstacles forward and aft.
- Quickly shift to the FORWARD position then back to the NEUTRAL position.
- Observe whether the boat moves in the direction you expect.

Neutral

1. Move the remote control handle to the N (Neutral) position. (The NEUTRAL lamp will come on)
2. When switching between forward and reverse, move the handle slowly between the forward and reverse positions. Move the handle firmly into either the forward or reverse position.

Forward

Move the handle toward F (forward) to the forward-side notch position. The engine will remain idling. Moving the handle forward further will increase the engine speed.

Reverse

Move the handle toward R (reverse) to the reverse-side notch position. The engine will remain idling. Pulling the handle back further will increase the engine speed.

Forward (Reverse) to Reverse (Forward)

Moving the handle quickly and switching from forward (reverse) to reverse (forward) will activate the gear shift delay (astern delay). The engine speed to decrease to idle speed for several seconds.

Note: The force required to move the throttle or shift handles can be adjusted with the Adjusting Screw.

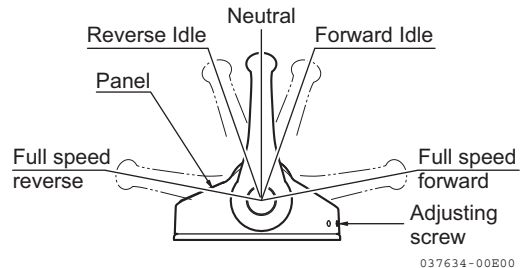

Figure 15

ENGINE SPEED LIMIT MODE

1. Move the remote control handle to the Forward Idle position. (Both sides in the case of twin engine.)
2. Press the “NTRL” switch of the selected station. (The lamp above “NTRL” switch will flash.)
3. Even if you tilt the handle to accelerate, the engine speed increases only up to the setting value.
4. Move the remote control handle to the N (Neutral), Forward Idle, or Reverse Idle position (both sides in the case of twin engine) and press the “NTRL” switch to release the [Engine Speed Limit Mode].

Note: The setting value can be set by the VC10 display. The default value is 50 %.

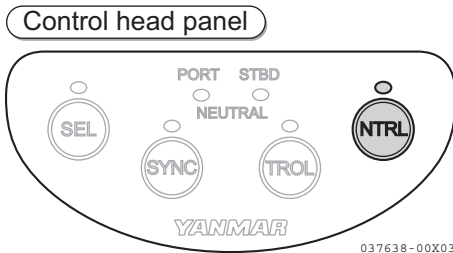

Figure 16

CAUTIONS DURING OPERATION

NOTICE

Engine trouble can arise if the engine is operated for a long time under overloaded conditions with the control handle in the full throttle position (maximum engine speed position), exceeding the continuous rated output engine speed. Operate the engine at about 100 min⁻¹ lower than the full throttle engine speed.

Note: If the engine is in the first 50 hours of operation, see New Engine Break-In on page 12 .

Always be on the lookout for problems during engine operation.

Pay particular attention to the following:

- Is sufficient seawater being discharged from the exhaust and seawater outlet pipe?

If the discharge is small, stop the engine immediately; identify the cause and repair.

- Is the smoke color normal?

The continuous emission of black exhaust smoke indicates engine overloading. This shortens the engines life and should be avoided.

- Are there abnormal vibrations or noise?

NOTICE

Excessive vibration may cause damage to the engine, marine gear, hull and onboard equipment. In addition, it causes able passenger and crew discomfort.

Depending on the hull structure, engine and hull resonance may suddenly become great at a certain engine speed range, causing heavy vibrations. Avoid operation in this speed range. If you hear any abnormal sounds, stop the engine and inspect.

- Alarm buzzer sounds during operation.

NOTICE

If any alarm indicator with audible alarm sound appears on the display during engine operation, stop the engine immediately. Determine the cause and repair the problem before you continue to operate the engine.

-
- Is there water, oil or fuel leakage, or are there any loose bolts?

Check the engine room periodically for any problems.

- Is there sufficient diesel fuel in the diesel fuel tank?

Replenish diesel fuel before leaving the dock to avoid running out of fuel during operation.

- When operating the engine at low speed for long periods of time, race the engine once every 2 hours.

NOTICE

Racing the engine: With the gear in NEUTRAL, accelerate from the low-speed position to the high-speed position and repeat this process about five times. This is done to clean out carbon from the cylinders and the fuel injection valve. Neglecting to race the engine will result in poor smoke color and reduce engine performance.

-
- If possible, periodically operate the engine at near maximum engine speed while underway. This will generate higher exhaust temperatures, which will help clean out hard carbon deposits, maintaining engine performance and prolonging the life of the engine.

NOTICE

Never turn off the battery switch (if equipped) or short the battery cables during operation. Damage to the electric system will result.

SHUT-DOWN THE ENGINE (STOPPING)

Stop the engine in accordance with the following procedures:

Normal Stopping

1. Move the remote control handle to the N (Neutral) position. (The NEUTRAL lamp will come on.)
2. Cool the engine down at low speed (below 1000 min⁻¹ (rpm)) for about 5 minutes.

NOTICE

For maximum engine life, Yanmar recommends that when shutting the engine down, you allow the engine to idle, without load, for 5 minutes. This will allow the engine components that operate at high temperatures, such as the turbo-charger and exhaust system, to cool slightly before the engine itself is shut down.

3. Press the Engine START/STOP switch on the switch panel of the selected station.
4. Press the Power switch and turn the power OFF.

CAUTION

Do not press the Engine START/STOP switch when the engine is stopped. The engine will restart.

5. Wait 6 seconds or more before turning the battery switch off for secure system settle down.

NOTICE

- Do not turn the battery switch off before turning the power switch off or immediately after turning off the power switch.
- Turning the battery switch off before secure system settle down may cause alarm to be set at the next activation by turning on the power switch. In an emergency situation, you can start the engine even if the alarm is set. In order to release above alarm, turn off the power switch and wait 6 seconds before turning the power switch on again.

6. Turn the battery switch off for engine and engine control system.
7. Close the fuel tank cock.
8. Close the seacock.

CAUTION

- **Be sure to close the seacock. Neglecting to close the seacock could allow water to leak into the boat and may cause it to sink.**
- **If seawater is left inside the engine, it may freeze and damage parts of the cooling system when the ambient temperature is below 0 °C (32 °F).**

Emergency Stop

Electric Emergency Stop

NOTICE

Never use the Emergency Stop switch for a normal engine shutdown. Use this switch only when stopping the engine suddenly in an emergency.

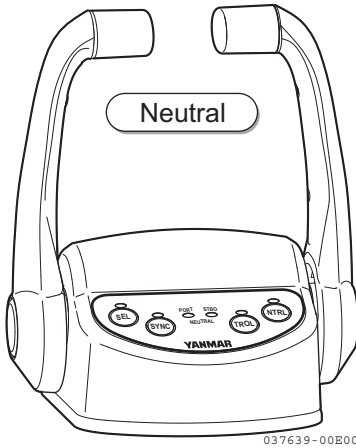

Figure 17

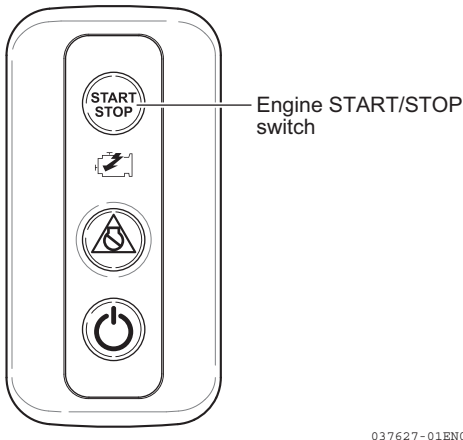
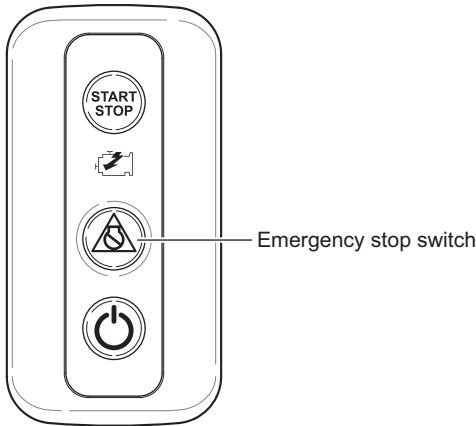

Figure 18

1. Pressing the Emergency Stop switch on the switch panel will stop the engine immediately.
2. The Emergency Stop screen will be shown on the display, and the buzzer will sound.
3. After the engine has stopped, press the Emergency Stop switch to release the emergency stop. After releasing, it may take sometime to restart.

Note:

1. *The Emergency Stop switch should only be used in emergencies. Use the Engine START/STOP switch to stop the engine normally.*
2. *The engine cannot be started while the Emergency Stop switch is pressed (emergency stop mode not canceled).*



037627-01EN01

Figure 19

NOTICE

- In case of emergency, turning off the battery switch for the engine control unit can also stop the engine immediately.
- You can restart the engine but an alarm may be set up when the power switch is turned on. Unless you are in an emergency situation, in order to release above alarm, turn off the power switch and wait 6 seconds before turning the power switch on again.

CONTROL THE BACKUP PANEL

⚠ WARNING

Only use this in an emergency.

1. Check that the power switch on the switch panel is OFF and that the remote control handle is in the N (Neutral) position.
2. Press the power switch to the “ON” position on the backup panel. The lamp will come and control by the backup panel is enabled.
3. The engine can be started or stopped with the START/STOP switch.
4. Adjust the engine speed using the sub throttle control volume. (anti-clockwise: lower engine speed, clockwise: raise engine speed)

When controlling the throttle, first move it fully anti-clockwise.

NOTICE

- The throttle of the engine that has been turned on can be controlled.
- When controlling the throttle, always move it fully anti-clockwise first.
- Be sure to lower the engine speed by turning the sub throttle volume fully to anti-clockwise before stopping the engine.
- The shift switch where is behind the left cover of Backup Panel.
- Shift switch does not work on 3/4JH common rail engines.

- In case that the marine gear can not be shifted by remote control handle for some reason such as broken cable, remove the cable from shift lever on the marine gear and shift manually by turning the lever.

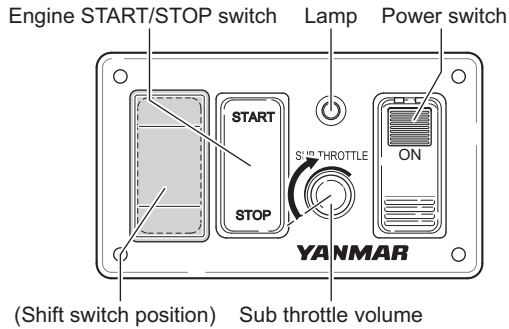

Figure 20

CHECKING THE ENGINE AFTER OPERATION

- Check that the power switch is off and that the battery switch (if equipped) is turned to off.
- Fill the fuel tank. *See Filling the Fuel Tank on page 41.*
- Close seawater cock(s).
- If there is a risk of freezing, check that the cooling system contains enough coolant. *See Engine Coolant Specifications on page 47.*
- If there is a risk of freezing, drain the seawater system. *See Drain Seawater Cooling System on page 120.*
- At temperatures below 0°C (32°F), drain seawater system and connect the engine heater (if equipped).

This Page Intentionally Left Blank

PERIODIC MAINTENANCE

INTRODUCTION

This section of the *Operation Manual* describes the procedures for proper care and maintenance of the engine.

SAFETY PRECAUTIONS

Before performing any maintenance procedures within this section, read the following safety information and review the *Safety* section on page 3.

WARNING

Crush Hazard



If the engine needs to be transported for repair, have a helper assist you attach it to a hoist and load it on a truck.

The engine lifting eyes are engineered to lift the weight of the marine engine only. Always use the engine lifting eyes when lifting the engine.

Additional equipment is necessary to lift the marine engine and marine gear together. Always use lifting equipment with sufficient capacity to lift the marine engine.

WARNING

Welding Hazard

- Always turn off the battery switch (if equipped) or disconnect the negative battery cable and the leads to the alternator when welding on the equipment.
- Remove the engine control unit multi-pin connector. Connect the weld clamp to the component to be welded and as close as possible to the welding point.
- Never connect the weld clamp to the engine or in a manner which would allow current to pass through a mounting bracket.
- When welding is completed, reconnect the alternator and engine control unit prior to reconnecting the batteries.

Entanglement Hazard



Never leave the power switch on when you are servicing the engine. Someone may accidentally start the engine and not realize you are servicing it.

Shock Hazard



Always turn off the battery switch (if equipped) or disconnect the negative battery cable before servicing the equipment.

Always keep the electrical connectors and terminals clean. Check the electrical harnesses for cracks, abrasions, and damaged or corroded connectors.

Never use undersized wiring for the electrical system.

Tool Hazard

Always remove any tools or shop rags used during maintenance from the area before operation.

NOTICE

Any part which is found defective as a result of inspection, or any part whose measured value does not satisfy the standard or limit, must be replaced.

Modifications may impair the engine's safety and performance characteristics and shorten the engine's life. Any alterations to this engine may void its warranty. Be sure to use Yanmar genuine replacement parts.

PRECAUTIONS

The Importance of Periodic Maintenance

Engine deterioration and wear occur in proportion to the length of time the engine has been in service and the conditions the engine is subjected to during operation. Periodic maintenance prevents unexpected downtime, reduces the number of accidents due to poor machine performance and helps extend the life of the engine.

Performing Periodic Maintenance

WARNING

Exhaust Hazard.

Never block windows, vents, or other means of ventilation if the engine is operating in an enclosed area. All internal combustion engines create carbon monoxide gas during operation. Accumulation of this gas within an enclosure could cause illness or even death. Make sure that all connections are tightened to specifications after repair is made to the exhaust system. Failure to comply could result in death or serious injury.

The Importance of Daily Checks

The Periodic Maintenance Schedule assumes that the daily checks are performed on a regular basis. Make it a habit to perform daily checks before the start of each operating day. *See Daily Checks on page 88.*

Keep a Log of Engine Hours and Daily Checks

Keep a log of the number of hours the engine is run each day and a log of the daily checks performed. Also note the date, type of repair (e.g., replaced alternator) and parts used for any service needed between the periodic maintenance intervals. Periodic maintenance intervals are every 50, 250, 500 and 1000 engine hours. Failure to perform periodic maintenance will shorten the life of the engine.

NOTICE

Failure to perform periodic maintenance will shorten the life of the engine and may void the warranty.

Yanmar Replacement Parts

Yanmar recommends that you use genuine Yanmar parts when replacement parts are needed. Genuine replacement parts help ensure long engine life.

Tools Required

Before you start any periodic maintenance procedure, make sure you have the tools you need to perform all of the required tasks.

Consult Your Authorized Yanmar Marine Dealer or Distributor for Help

Our professional service technicians have the expertise and skills to help you with any maintenance or service related procedures you need help with.

PERIODIC MAINTENANCE

Tightening Fasteners

Use the correct amount of torque when you tighten fasteners on the engine. Applying excessive torque may damage the fastener or component and not enough torque may cause a leak or component failure.

NOTICE



The tightening torque in the Standard Torque Chart should be applied only to the bolts with a "8.8" head (JIS strength classification: 8.8). Apply 60% torque to bolts that are not listed. Apply 80% torque when tightened to aluminum alloy.

Bolt Diameter x Pitch (mm)		M6x1.0	M8x1.25	M10x1.5	M12x1.75	M14x1.5	M16x1.5
Tightening Torque	N·m	10.8 ± 1.0	25.5 ± 3.0	49 ± 5.0	88.2 ± 10.0	140.0 ± 10.0	230.0 ± 10.0
	ft·lb	8.0 ± 0.7	18.8 ± 2.2	36.2 ± 3.7	65.1 ± 7.4	103 ± 7.2	170 ± 7.2

Taper Plugs		1/8	1/4	3/8	1/2
Tightening Torque	N·m	9.8	19.6	29.4	58.8
	ft·lb	7.4	14.5	21.7	43.2

When lock adhesive is applied, decide separately.

Pipe Joint Bolts		M8	M10	M12	M14	M16
Tightening Torque	N·m	14.7 ± 2	22.5 ± 3	29.4 ± 5	44.1 ± 5	53.9 ± 5
	ft·lb	10.9 ± 1.5	16.6 ± 2.2	21.7 ± 3.7	32.6 ± 3.7	69.8 ± 3.7

When seal washer applied, torque is 34 ± 5 N·m (25.1 ± 3.7 ft·lb).

Main Bolts and Nuts

Name		Thread Diameter x Pitch	Lubricating Oil Application (thread portion and seat surface)	Torque N-m (ft-lb)	
Head bolt		M10 x 1.25	Apply oil	88.2 ± 2.9 (65.1 ± 2.1)	
Connecting rod bolt		M9 x 1.0	Apply oil	44.1 ^{+4.9/0} (32.5 ^{+3.6/0})	
Flywheel bolt		M10 x 1.25	Apply oil	83.3 ^{+4.9/0} (61.4 ^{+3.6/0})	
Metal cap bolt		M12 x 1.5	Apply oil	98.0 ± 2.0 (72.3 ± 1.5)	
Crank pulley bolt		M14 x 1.5	Apply oil	88.2 ± 4.9 (65.1 ± 3.6)	
Injector retainer bolt		M8 x 1.25	Without oil	26.4 ± 2.0 (19.5 ± 1.5)	
Rocker arm support bolt		M8 x 1.25	Without oil	25.5 ± 1.5 (18.8 ± 1.1)	
Rocker arm cover nut		M8 x 1.25	Without oil	13.5 ± 0.5 (10.0 ± 0.4)	
Supply pump gear nut		M18 x 1.5	Without oil	80.0 ± 5.0 (59.0 ± 3.7)	
Retainer bolt for Flywheel speed sensor		M6 x 1.0	Without oil	8.0 ± 2.0 (5.9 ± 1.5)	
Retainer bolt for Cam shaft speed sensor		M6 x 1.0	Without oil	8.0 ± 0.5 (5.9 ± 0.4)	
Retainer nut for Lubricating Oil Cooler		M20 x 1.5	Without oil	78.5 ± 4.9 (57.9 ± 3.6)	
High pressure pipe nut	Injector	M12 x 1.5	Without oil	29.4 ^{+2/-4.4} (21.7 ^{+1.5/-3.2})	
	Rail	M12 x 1.5	Without oil		
	Pump	M16 x 1.0	Without oil		
Glow plug		M10 x 1.25	Without oil	Body	14.7 to 19.6 (10.8 to 14.5)
		M4 x 0.7		Terminal nut	1.0 to 1.5 (0.7 to 1.1)
Heat exchanger set bolt		M8 x 1.25	Without oil	37.2 ± 3.0 (27.4 ± 2.2)	
Pressure sensor		M6 x 1.0	Without oil	7.0 ± 1.4 (5.2 ± 1.0)	
Starter relay terminal nut		M6 x 1	Without oil	3.6 ± 0.6 (2.7 ± 0.4)	

EPA MAINTENANCE REQUIREMENTS

To maintain optimum engine performance and compliance with the Environmental Protection Agency (EPA) Regulations for Engines, it is essential that you follow the *Periodic Maintenance Schedule on page 85* and the *Periodic Maintenance Procedures on page 88*.

EPA Requirements for USA and Other Applicable Countries

The following are the requirements for the EPA. Unless these requirements are met, the exhaust gas emissions will not be within the limits specified by the EPA.

See Conditions to Ensure Compliance with EPA Emission Standards on page 83. Clean or replace the air cleaner element if the air intake restriction exceeds the referenced specifications.

EPA Requirements

The EPA emission regulation is applicable only in the USA and other countries that have adopted the EPA requirements in part or in whole. Determine and follow the emission regulations in the country where your engine will be operating to assist you in specified compliance.

Conditions to Ensure Compliance with EPA Emission Standards

The 3JH40, 4JH45, 4JH57, 4JH80 and 4JH110 are EPA-certified engines.

The following are the conditions that must be met in order to ensure that the emissions during operation meet the EPA standards.

The operating conditions should be as follows:

- Ambient temperature: -20° to +40°C (-4°F to +104°F)
- Relative humidity: 80% or lower

The diesel fuel should be:

- ASTM D975 No. 1-D S15, No. 2-D S15, or equivalent (minimum of cetane No. 45)

The lubricating oil should be:

- API Service Categories CD, CF, CF-4, CI and CI-4.

Be sure to perform inspections as outlined in *Periodic Maintenance Procedures on page 88* and keep a record of the results.

Pay particular attention to these important points:

- Replacing the engine oil
- Replacing the engine oil filter
- Replacing the fuel filter
- Cleaning the intake silencer (air cleaner)

Note: Inspections are divided into two sections in accordance with who is responsible for performing the inspection: the user or the maker.

Inspection and Maintenance

See *Inspection and Maintenance of Emission-Related Parts on page 87* for the EPA emission-related parts. Inspection and maintenance procedures not shown in *Inspection and Maintenance of Emission-Related Parts on page 87* are covered in *Periodic Maintenance Schedule on page 85*.

This maintenance must be performed to keep the emission values of your engine in the standard values during the warranty period. The warranty period is determined by the age of the engine or the number of hours of operation.

Installation of Exhaust Sampling Port

All engines subject to emission standards shall be equipped with a connection in the engine exhaust system that is located downstream of the engine, and before any point at which the exhaust contacts water (or any other cooling / scrubbing medium), for the temporary attachment of gaseous and / or particulate emissions sampling equipment. This connection shall be internally threaded with standard pipe threads of a size not larger than 12.7 mm (0.5 in.), and shall be closed by a pipe plug when not in use. Equivalent connections are allowed.

The instructions for the proper installation and location of the required sample port, in addition to those specified above in the quoted federal regulation, are follows:

1. The connection should be located as far downstream as reasonably practicable from any sharp bend (of 30 degrees or more) in the exhaust pipe to help ensure that a well-mixed exhaust flow sample may be taken;
2. The requirement that the connection be located before any point at which the exhaust contacts water (or any other cooling / scrubbing medium) does not include contact with water used to cool exhaust manifolds, unless the water is allowed to come into direct contact with the exhaust gases;
3. To allow ready access to the sample port, the connection should be located, if possible given the constraints of vessel design, approximately 0.6 to 1.8 m (2 to 6 ft) above a deck or walkway;
4. To facilitate insertion and withdrawal of an exhaust sample probe, there should be no obstructions for at least one and one-half exhaust pipe / stack diameters perpendicular, i.e., 90 degrees, from the sample port; and
5. If a threaded connection is used, both the internal and external threads should be coated with a high-temperature, anti-seize compound before the initial installation and at every subsequent re-installation to facilitate removal of the connection for testing.

PERIODIC MAINTENANCE SCHEDULE

Daily and periodic maintenance is important to keep the engine in good operating condition. The following is a summary of maintenance items by periodic maintenance intervals. Periodic maintenance intervals vary depending on engine application, loads, diesel fuel and engine oil used and are hard to establish definitively. The following should be treated only as a general guideline.

NOTICE

Establish a periodic maintenance plan according to the engine application and make sure to perform the required periodic maintenance at the intervals indicated. Failure to follow these guidelines will impair the engine's safety and performance characteristics, shorten the engine's life and may affect the warranty coverage on your engine.

Consult authorized Yanmar Marine dealer or distributor for assistance when checking items marked with a ●.

○: Check or Clean ◇: Replace ●: Consult your authorized Yanmar Marine dealer or distributor

System	Item	Periodic Maintenance Interval				
		Daily <i>See Daily Checks on page 88.</i>	Every 50 hours or monthly which-ever comes first	Every 250 hours or 1 year which-ever comes first	Every 500 hours or 2 years which-ever comes first	Every 1000 hours or 4 years which-ever comes first
Whole	Visual inspection of engine exterior	○				
Fuel System	Check the fuel level and refill if necessary	○				
	Drain water and sediment from fuel tank		○ Initial 50	○		
	Drain the fuel/water separator		○			
	Replace the fuel filter element			◇		
Lubricating System	Check the lube oil level	Engine	○			
		Marine Gear	○			
	Replace the lube oil	Engine		◇ Initial 50	◇	
		Marine Gear		◇ Initial 50	◇	
	Replace the oil filter element	Engine		◇ Initial 50	◇	
		Marine Gear (if equipped)		◇ Initial 50	◇	

PERIODIC MAINTENANCE

○: Check or Clean ◇: Replace ●: Consult your authorized Yanmar Marine dealer or distributor

System	Item	Periodic Maintenance Interval				
		Daily <i>See Daily Checks on page 88.</i>	Every 50 hours or monthly which-ever comes first	Every 250 hours or 1 year which-ever comes first	Every 500 hours or 2 years which-ever comes first	Every 1000 hours or 4 years which-ever comes first
Cooling System	Seawater outlet	○ During Operation				
	Check coolant level	○				
	Check or replace the seawater pump impeller			○		◇
	Replace coolant	Every year. When Long Life Coolant is used, replace every 2 years. <i>See Engine Coolant Specifications on page 47.</i>				
	Clean and check the seawater passages					●
Air Intake and Exhaust System	Clean intake silencer (air cleaner) element			○		
	Clean or replace the exhaust/water mixing elbow			○	◇	
	Wash the turbocharger blower - 4JH80/4JH110 only			●		
	Check diaphragm assembly 3JH40/4JH45/4JH57 only					●
Electrical System	Check the alarm and indicators	○				
	Check the electrolyte level in the battery		○			
	Adjust the tension of the alternator V-ribbed belt or replace V-ribbed belt		○ Initial 50	○		◇
	Check the wiring connectors			○		
Engine Cylinder Head and Block	Check for leakage of fuel, engine oil and engine coolant	○ After starting				
	Tighten all major nuts and bolts			●		
	Adjust intake/exhaust valve clearance		● Initial 50			●
Miscellaneous Items	Check the remote control cable operation		○ Initial 50			●
	Adjust the propeller shaft alignment		● Initial 50			●
	Replace rubberized hoses (fuel and water)	Replace every 2 years.				

Note: These procedures are considered normal maintenance and are performed at the owner's expense.

Inspection and Maintenance of Emission-Related Parts

- Marine Compression-Ignition (CI) engines less than 37 kW: 3JH40 and 4JH45 common rail engines are certified by EPA and ARB
- Marine diesel engines greater than 37 kW: 4JH57, 4JH80 and 4JH110 common rail engines are certified as EPA CI marine engines

Inspection and Maintenance of Emission-Related Parts of Marine CI Engines

Parts	Minimum Interval
Clean fuel injectors	1500 hours
Check fuel injectors	3000 hours
Check turbocharger adjustment (if equipped)	
Check electronic engine control unit and its associated sensors and actuators (if equipped)	

Note: Yanmar recommends that the inspection and maintenance items shown above be performed at an authorized Yanmar dealer or distributor.

PERIODIC MAINTENANCE PROCEDURES

WARNING

Exposure Hazard.

Always wear personal protective equipment when performing periodic maintenance procedures.

Daily Checks

Before you head out for the day, make sure the Yanmar engine is in good operating condition.

NOTICE

It is important to perform the daily checks as listed in this Operation Manual. Periodic maintenance prevents unexpected downtime, reduces the number of accidents due to poor engine performance and helps extend the life of the engine.

Make sure you check the following items.

Visual Checks

1. Check for engine oil leaks.
2. Check for fuel leaks.

WARNING

Piercing Hazard.

Avoid skin contact with the high-pressure diesel fuel spray caused by a fuel system leak, such as a broken fuel injection line. High-pressure fuel can penetrate your skin and result in serious injury. If you are exposed to high-pressure fuel spray, obtain prompt medical treatment. Never check for a fuel leak with your hands.

Always use a piece of wood or cardboard. Have your authorized Yanmar Marine dealer or distributor repair any damage.

3. Check for engine coolant leaks.
4. Check for damaged or missing parts.
5. Check for loose, missing or damaged fasteners.
6. Check the electrical harnesses for cracks, abrasions, and damaged or corroded connectors.
7. Check hoses for cracks, abrasions, and damaged, loose or corroded clamps.
8. Check the fuel filter/water separator for presence of water and contaminants. If you find any water or contaminants, drain the fuel filter/water separator. *See Draining Fuel Filter/Water Separator on page 95.* If you have to drain the fuel filter/water separator frequently, drain the fuel tank and check for the presence of water in your fuel supply. *See Draining the Fuel Tank on page 89.*

NOTICE

If any problem is noted during the visual check, the necessary corrective action should be taken before operating the engine.

Check Diesel Fuel, Engine Oil and Engine Coolant Levels

Follow the procedures in *Diesel Fuel on page 38*, *Engine Oil on page 43* and *Engine Coolant on page 47* to check these levels.

Checking and Refilling Marine Gear Oil

Refer to the *Operation Manual* for the marine gear.

Checking the Battery Electrolyte Level

Check the battery electrolyte level before use. See *Checking the Battery Electrolyte Level (Serviceable Batteries Only)* on page 96.

Checking the Alternator Belt

Check the belt tension before use. See *Checking and Adjusting the Alternator V-ribbed belt Tension* on page 91.

Checking the Remote Control Handle

Check the operation of the remote control handle and ensure it moves smoothly. If it is hard to operate, grease the joints of the remote control cable and lever bearings. If the lever is too loose, adjust the remote control cable. See *Checking and Adjusting Remote Control Cables* on page 93.

Checking the Alarm Indicators

When operating the start switch on the instrument panel, check that there is no alarm message on the display and the alarm indicators work normally. See *Control Equipment* on page 20.

Preparing Fuel, Oil and Coolant in Reserve

Prepare sufficient fuel for the days operation. Always store engine oil and coolant in reserve (for at least one refill) onboard, to be ready for emergencies.

After Initial 50 Hours of Operation

Perform the following maintenance after the initial 50 hours of operation.

- **Draining the Fuel Tank**
- **Changing the Engine Oil and Replacing the Engine Oil Filter Element**
- **Changing the Marine Gear Oil and Replacing the Marine Gear Oil Filter (If Equipped)**
- **Checking and Adjusting the Alternator V-ribbed belt Tension**
- **Inspecting and Adjusting Intake/Exhaust Valve Clearance**
- **Checking and Adjusting the Remote Control Cables**
- **Adjusting Propeller Shaft Alignment**

Draining the Fuel Tank

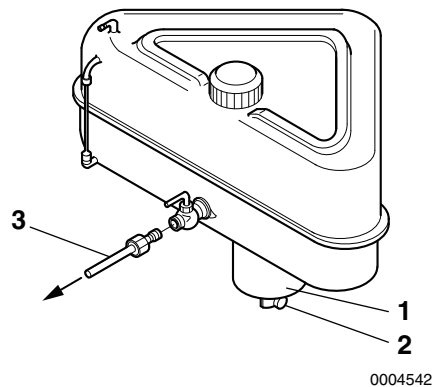

Figure 1

Note: Optional fuel tank shown. Actual equipment may differ.

PERIODIC MAINTENANCE

1. Put a pan under the drain cock (**Figure 1, (2)**) to catch fuel.
2. Open the drain cock and drain water and sediment. Close the drain cock when the fuel is clean and free of air bubbles.

Changing the Engine Oil and Replacing the Engine Oil Filter Element

The engine oil on a new engine becomes contaminated from the initial break-in of internal parts. It is very important that the initial oil replacement is performed as scheduled.

It is easiest and most available to drain the engine oil after operation while the engine is still warm.

⚠ WARNING

Burn Hazard.

If you must drain the engine oil while it is still hot, stay clear of the hot engine oil to avoid being burned. Always wear eye protection.

1. Turn the engine off.
2. Remove the engine oil dipstick. Attach the oil drain pump (if equipped) and pump out the oil.
For easier draining, remove the engine oil fill cap. Dispose of used oil properly.

NOTICE

- Prevent dirt and debris from contaminating engine oil. Carefully clean the dipstick and the surrounding area before removing the dipstick.
- Always be environmentally responsible.

3. Remove the engine oil filter (**Figure 2**) with a filter wrench (turn counterclockwise).

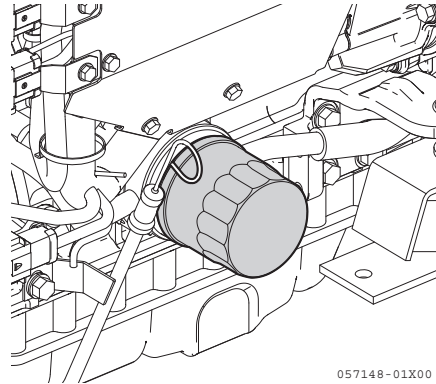

Figure 2

Note: 4JH45/4JH57 shown.

4. Install a new filter element and tighten by hand until the seal touches the housing.
5. Turn filter an additional 3/4 turn clockwise with a box wrench. Tighten to 20 to 24 N·m (177 to 212 in.-lb).
6. Fill with new engine oil. *See Adding Engine Oil on page 45.*

NOTICE

Never mix different types of engine oil. This may adversely affect the lubricating properties of the engine oil. Never overfill. Overfilling may result in white exhaust smoke, engine overspeed or internal damage.

7. Perform a trial run and check for oil leaks.
8. Approximately 10 minutes after stopping the engine, remove the oil dipstick and check the oil level. Add oil if the level is too low.

NOTICE

Be careful not to get any oil on the V-ribbed belt. Oil on the belt causes slipping and stretching. Replace the belt if it is damaged.

Changing the Marine Gear Oil and Replacing the Marine Gear Oil Filter (If Equipped)

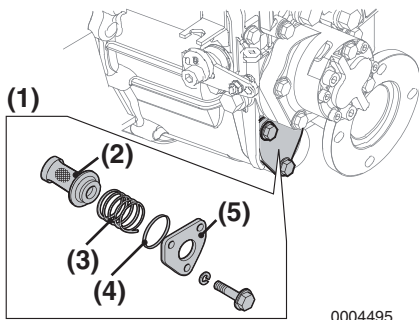

Figure 3

0004495

Note: 4JH80/4JH110 engines with KMH4A marine gear shown. Refer to the Operation Manual for the marine gear or sail drive for procedure.

1. Remove cap from the filler port and attach an oil drain pump. Drain marine gear oil.

NOTICE

Always be environmentally responsible.

2. KMH4A Marine Gear:

Wash the marine gear oil filter:

- (a) Remove side cover (**Figure 3, (5)**) and remove the filter (**Figure 3, (2)**).
- (b) Clean the filter thoroughly with kerosene or clean diesel fuel.

- (c) Hold the filter in place with the coil spring (**Figure 3, (3)**) and insert into the case. Install a new O-ring (**Figure 3, (4)**) in the side cover.
- (d) Install side cover and tighten side cover bolts.

3. Fill marine gear with clean marine gear oil. See *Marine Gear Oil Specifications on page 45*.
4. Perform a trial run and check for oil leaks.
5. Approximately 10 minutes after stopping the engine, remove the oil dipstick and check the oil level. Add oil if the level is too low.

Checking and Adjusting the Alternator V-ribbed belt Tension

⚠ WARNING

Sever Hazard.

Perform this check with the power switch off and the battery switch turned off to avoid contact with moving parts.

NOTICE

- When there is not enough tension in the V-ribbed belt, it will slip and the coolant pump will fail to supply coolant. Engine overheating and seizure will result.
- Never get any oil on the belt(s). Oil on the belt causes slipping and stretching. Replace the belt if it is damaged.

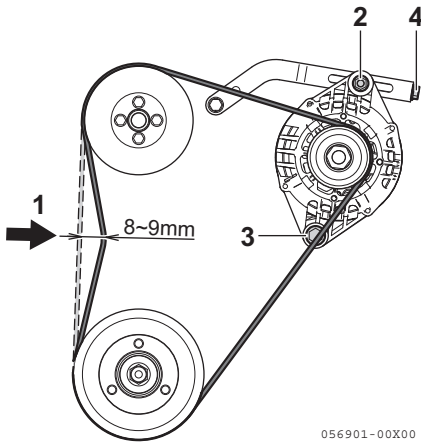

Figure 4

Note: 4JH110 shown.

1. Remove the belt cover.
2. Check the belt by pushing on the middle of the belt (**Figure 4, (1)**) with your finger. (Pressed by 100 N)
With proper tension, the belt should deflect 8 to 9 mm.

Note: Check the tension of the V-ribbed belt after operating the engine at idle for 5 minutes.

3. Loosen the 3 bolts of alternator (**Figure 4, (2) (3) (4)**).
4. Screw in the adjusting bolt (**Figure 4, (4)**) and move the alternator to adjust the belt tension properly.
5. Tighten the 3 bolts of the alternator.
6. Install the belt cover.

Inspecting V-Ribbed Belt

1. Visually check the belt for excessive wear, frayed cords, etc.
If any defects are found, replace the V-ribbed belt.
2. Check that the belt fits properly in the ribbed grooves.

NOTICE

Confirm by hand that the belt has not slipped out of the grooves on the bottom of the pulley.

Checks on the rib side of the belt are considered acceptable. If the belt has chunks missing from the ribs, it should be replaced.

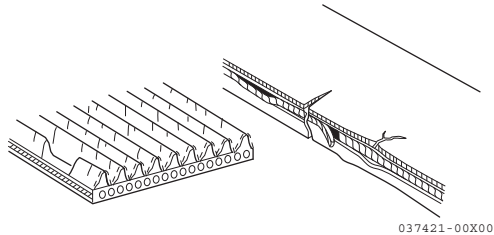

Figure 5



Figure 6

Inspecting and Adjusting Intake/Exhaust Valve Clearance

Proper adjustment is necessary to maintain the correct timing for opening and closing the valves. Improper adjustment will cause the engine to run noisily, resulting in poor engine performance and engine damage. Consult authorized Yanmar Marine dealer or distributor to adjust the intake/exhaust valve clearance.

Checking and Adjusting Remote Control Cables

Adjusting Engine Speed Remote Control Cable

Ensure the control lever on the engine side moves to the high-speed stop position and low-speed stop position when the remote control lever is moved to HIGH and then to LOW.

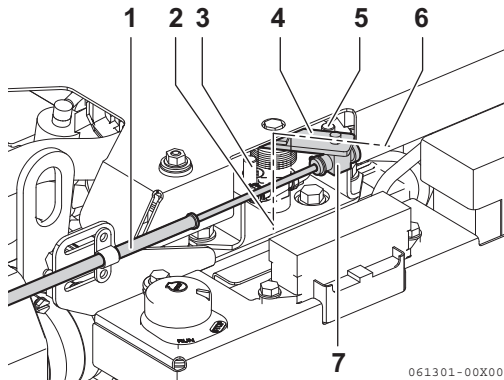

Figure 7

- 1 – Cable
- 2 – High-speed stop position
- 3 – High-speed stop pin
- 4 – Control lever
- 5 – Low-speed stop pin
- 6 – Low-speed stop position
- 7 – Adjustment screw

1. To adjust, loosen the adjustment screw (**Figure 7, (7)**) for the remote control cable and adjust.
2. Adjust the low-speed stop position (**Figure 7, (6)**) first and then adjust the high-speed stop position (**Figure 7, (2)**), with the adjustment screw on the remote control lever (**Figure 7, (4)**).

Adjusting Marine Gear Remote Control Cable

KM35P

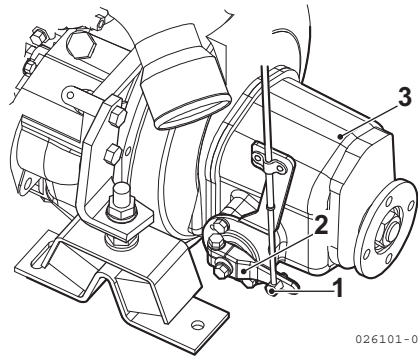

026101-00X01

Figure 8

KMH4A

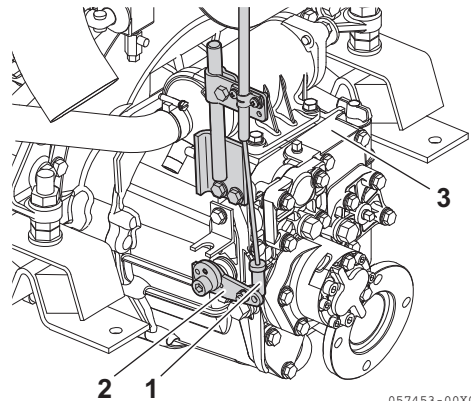

057453-00X00

Figure 9

1. Ensure that the remote control lever (**Figure 8, (2)**) or (**Figure 9, (2)**) moves to the correct position when the remote control handle is in the NEUTRAL, FORWARD and REVERSE positions. Use the NEUTRAL position as the standard for adjustment.
2. To adjust, loosen and retighten the cable fitting (**Figure 8, (1)**) or (**Figure 9, (1)**).

PERIODIC MAINTENANCE

Adjusting Trolling Remote Control Handle - If Equipped

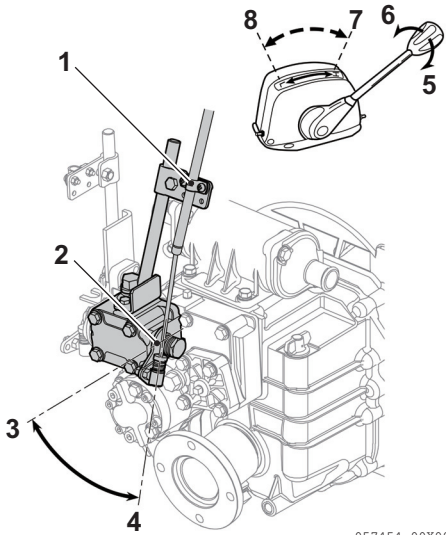

057454-00X00

Figure 10

- 1 – Cable Fitting**
- 2 – Trolling Lever**
- 3 – Low Speed (trolling)**
- 4 – High Speed**
- 5 – Loosen**
- 6 – Tighten**
- 7 – Normal Operation (high speed)**
- 8 – Trolling (low speed)**

Note: KMH4A marine gear shown.

1. Ensure that the trolling lever (**Figure 10, (2)**) is in the high-speed (**Figure 10, (4)**) position when the trolling remote control handle is in high-speed position (**Figure 10, (7)**).
2. Ensure that the trolling lever is in the low-speed (**Figure 10, (3)**) position when the trolling remote control handle is in low-speed position (**Figure 10, (8)**).
3. To adjust, loosen the adjustment screw of the cable fitting (**Figure 10, (1)**) and adjust the position of the cable.

Adjusting Propeller Shaft Alignment

The flexible engine mounts are compressed slightly during initial engine operation and may cause misalignment between the engine and the propeller shaft.

After the first 50 hours of operation, the alignment should be checked and readjusted if necessary. This is considered normal maintenance and the adjustment requires specialized knowledge and techniques. Consult your authorized Yanmar Marine dealer or distributor.

Check for any unusual noise and vibration in the engine/boat hull, while increasing and decreasing the engine speed gradually.

If there is unusual noise and/or vibration, this maintenance requires specialized knowledge and techniques. Consult authorized Yanmar Marine dealer or distributor to adjust the propeller shaft alignment.

Every 50 Hours of Operation

Perform the following procedures every 50 hours thereafter or monthly, whichever comes first.

- **Draining Fuel Filter/Water Separator**
- **Checking Battery Electrolyte Level (Serviceable Batteries Only)**

Draining Fuel Filter/Water Separator

⚠ WARNING

Fire and Explosion Hazard.

When removing any fuel system component to perform maintenance (such as changing the fuel filter), put an approved container under the opening to catch the fuel.

Never use a shop rag to catch the fuel. Vapors from the rag are flammable and explosive. Wipe up any spills immediately.

Exposure Hazard.

Wear eye protection. The fuel system is under pressure and fuel could spray out when removing any fuel system component.

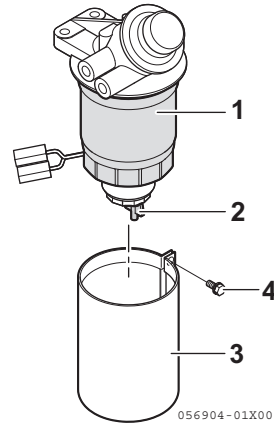

Figure 11

- 1 – Filter element
- 2 – Drain plug
- 3 – Cover (fire-resistant)
- 4 – Clamp screw

NOTICE

If the fuel filter/water separator is positioned higher than the fuel level in the fuel tank, water may not drip out when the fuel filter/water separator drain cock is opened. If this happens, turn the air vent screw on the top of the fuel filter/water separator two to three turns counterclockwise. Be sure to tighten the air vent screw after the water has drained out.

1. Close the fuel tank cock.
2. Loosen the clamp screw and remove the fire-resistant cover, which is installed to the lower part of the fuel filter/water separator to protect the water alarm switch.
3. Attach a tube to the drain plug.
4. Loosen the drain plug (**Figure 11, (2)**) at the bottom of the fuel filter/water separator by turning counterclockwise and drain off any water or sediment.

PERIODIC MAINTENANCE

Note: If there is a large quantity of water and sediment in the fuel filter/water separator, also drain the fuel tank. See Draining the Fuel Tank on page 89.

NOTICE

Always be environmentally responsible. Dispose of the collected water and dirt properly.

5. Tighten the drain plug.
6. Remove the drain tube.
7. Install the fire-resistant cover and tighten the clamp screw.
8. Bleed air from the fuel system. See *Bleeding the Fuel System on page 42.*

Checking the Battery Electrolyte Level (Serviceable Batteries Only)

WARNING

Exposure Hazard.

Batteries contain sulfuric acid. Never allow battery fluid to come in contact with clothing, skin or eyes. Severe burns could result. Always wear safety goggles and protective clothing when servicing the battery. If battery fluid contacts the eyes and/or skin, immediately flush the affected area with a large amount of clean water and obtain prompt medical treatment.

NOTICE

Never turn off the battery switch (if equipped) or short the battery cables during operation. Damage to the electric system will result.

NOTICE

Never operate with insufficient battery electrolyte. Operating with insufficient electrolyte will destroy the battery.

Battery fluid tends to evaporate in high temperatures, especially in summer. In such conditions, inspect the battery earlier than specified.

1. Turn off the battery switch (if equipped) or disconnect the negative (-) battery cable.
2. Do not operate with insufficient battery electrolyte, as the battery will be destroyed.
3. Remove the plugs and check the electrolyte level in all cells.

NOTICE

Never attempt to remove the covers or fill a maintenance-free battery.

4. If the level is lower than the minimum fill level (**Figure 12, (1)**), fill with distilled water (**Figure 12, (2)**) (available in the grocery store) up to the upper limit (**Figure 12, (3)**) of the battery.

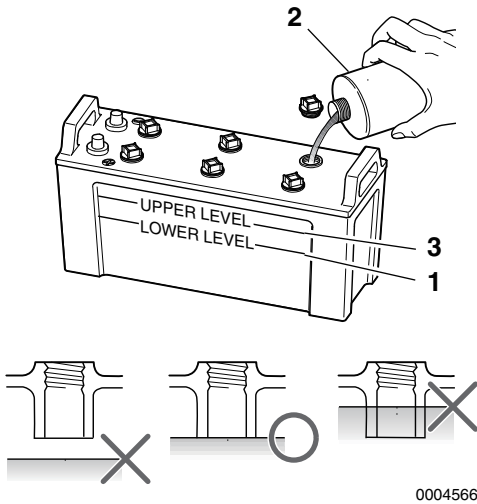

Figure 12

Note: The maximum fill level is approximately 10 to 15 mm (3/8 to 9/16 in.) above the plates.

Every 250 Hours of Operation

Perform the following maintenance every 250 hours or 1 year of operation, whichever comes first.

- **Draining the Fuel Tank**
- **Replacing the Fuel Filter Element**
- **Changing the Engine Oil and Replacing the Engine Oil Filter Element**
- **Changing the Marine Gear Oil and Replacing Marine Gear Oil Filter Element (If Equipped)**
- **Checking or Replacing the Seawater Impeller**
- **Changing the Coolant**
- **Cleaning the Intake Silencer (Air Cleaner) Element**
- **Cleaning the Exhaust/Water Mixing Elbow**
- **Wash the Turbocharger blower (If Equipped)**
- **Adjusting the Alternator V-ribbed belt Tension**
- **Checking the Wiring Connectors**
- **Tightening All Major Nuts and Bolts**

Draining the Fuel Tank

See Draining the Fuel Tank on page 89.

PERIODIC MAINTENANCE

Replacing the Fuel Filter Element

⚠ WARNING

Fire and Explosion Hazard.

When removing any fuel system component to perform maintenance (such as changing the fuel filter), put an approved container under the opening to catch the fuel.

Never use a shop rag to catch the fuel. Vapors from the rag are flammable and explosive. Wipe up any spills immediately.

Exposure Hazard.

Wear eye protection. The fuel system is under pressure and fuel could spray out when removing any fuel system component.

Fuel pre-filter/water separator

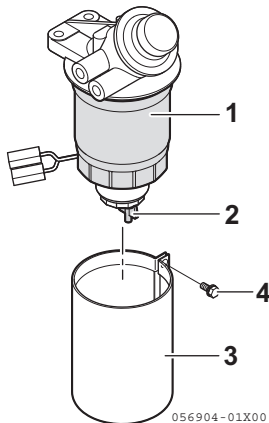

Figure 13

- 1 – Filter element
- 2 – Drain plug
- 3 – Cover (fire-resistant)
- 4 – Clamp screw

1. Close the fuel tank cock.
2. Loosen the clamp screw and remove the fire-resistant cover, which is installed to the lower part of the fuel pre-filter / water separator to protect the water alarm switch.
3. Attach a tube to the drain plug.
4. Loosen the drain plug and drain the fuel from the drain plug.
5. Disconnect the electrical connectors and remove the alarm switch with a spanner wrench.
6. Remove the filter element with a filter wrench.
7. Clean the filter element mounting surface. Install new filter element.

Component	Part No.
Fuel pre-filter	121857-55710

8. Install the alarm switch to the fuel pre-filter. Apply clean fuel to the gasket of the new fuel pre-filter.
9. Install filter element into engine and hand-tighten until the gasket comes into contact with the seat. Use a filter wrench and tighten approximately 3/4 turn to 12.7 to 16.7 N·m (9.4 to 12.3 ft.-lb).
10. Install the fire-resistant cover and tighten the clamp screw.
11. Bleed the fuel system. *See Bleeding the Fuel System on page 42.*
12. Dispose of waste properly.

Fuel filter

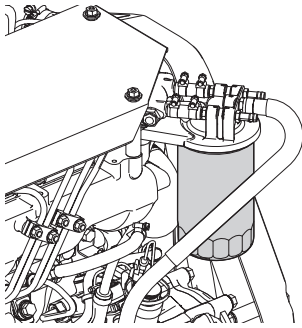

056905-00X00

Figure 14

1. Close the fuel tank cock.
2. Remove the fuel filter with a filter wrench.

Note: When removing the fuel filter, hold the bottom of the fuel filter with a cloth to prevent the fuel from spilling. Wipe up any spilled fuel immediately.

3. Apply a thin film of clean diesel fuel to the sealing surface of the new filter gasket.

Component	Part No.
Fuel filter	129A00-55800

4. Install a new filter and hand-tighten. Use a filter wrench and tighten to 20 to 24 N·m (14.75 to 17.7 ft-lb).
5. Bleed the fuel system. *See Bleeding the Fuel System on page 42.* Dispose of waste properly.
6. Check for fuel leaks.

Changing the Engine Oil and Replacing the Engine Oil Filter Element

See Changing the Engine Oil and Replacing the Engine Oil Filter Element on page 90.

Changing the Marine Gear Oil and Replacing the Marine Gear Oil Filter Element (if equipped)

See Changing the Marine Gear Oil and Replacing the Marine Gear Oil Filter Element (if equipped) on page 99.

Checking or Replacing Seawater Pump Impeller

1. Loosen side cover bolts and remove the side cover.
2. Inspect the inside of the seawater pump with a flashlight. If any of the following are found, disassembly and maintenance are required:
 - Impeller blades are cracked or nicked. Edges or surfaces of the blades are marred or scratched.
 - Wear plate is damaged.
3. If no damage is found when inspecting the inside of the pump, install the O-ring and side cover.
4. If a large amount of water leaks continuously from the water drain line below the seawater pump during operation, replace the mechanical seal. Consult authorized Yanmar Marine dealer or distributor.

Replacing the Seawater Pump Impeller

Note: The impeller must be replaced periodically (every 1000 hours) even if there is no damage.

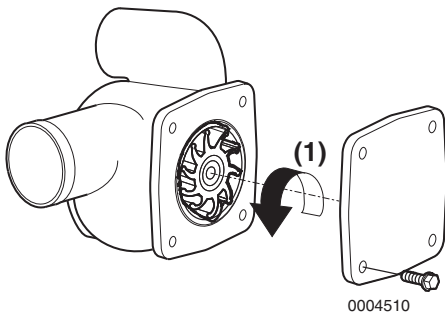

Figure 15

Special service tools for removing the impeller:

**Puller A (standard)
Part No. 129671-92110**

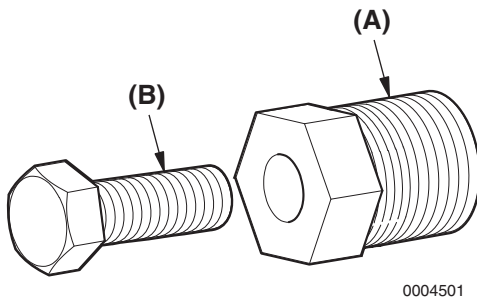

Figure 16

Puller A	Jack Screw B
M18x1.5	M10x40 mm length

1. Remove the side cover of the seawater pump.
2. Install puller (**Figure 16, (A)**) in the impeller.
3. Turn the jack screw (**Figure 16, (B)**) clockwise to remove the impeller from the pump body.

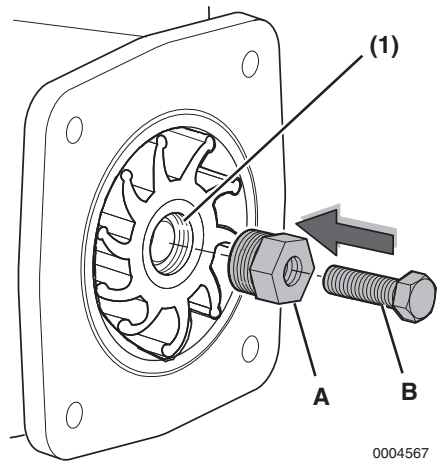

Figure 17

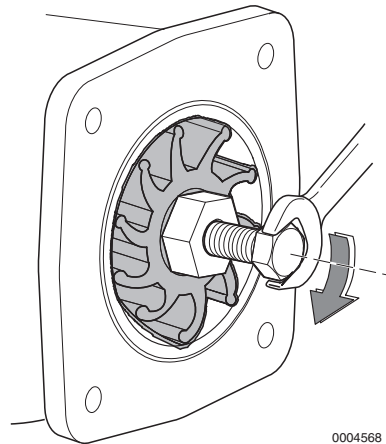

Figure 18

*Note: When replacing a used impeller with a new one, the impeller must have an M18x1.5 thread (**Figure 17, (1)**). Turn the M18 screw side of the impeller to the cover side and install (**Figure 18**).*

Changing the Coolant

3JH40

CAUTION

Coolant Hazard.

Wear eye protection and rubber gloves when you handle engine coolant. If contact with the eyes or skin should occur, flush eyes and wash immediately with clean water.

Change the coolant every year.

NOTICE

Never mix different types and/or colors of coolants.

Discard old coolant in an approved manner according to environmental laws.

Note: If Long Life coolant is used, replace coolant every 2 years.

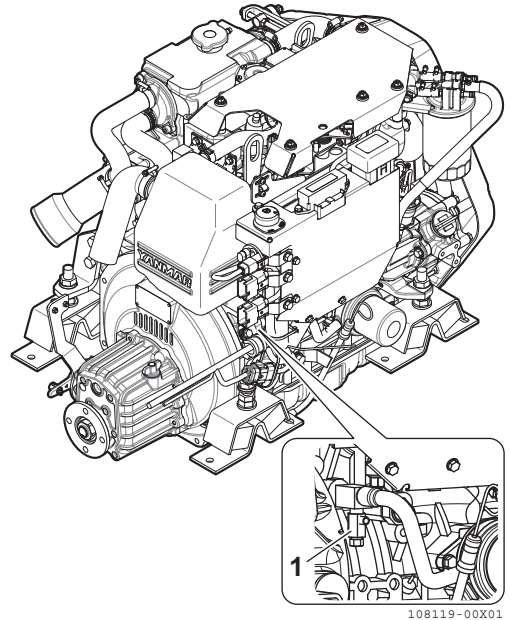
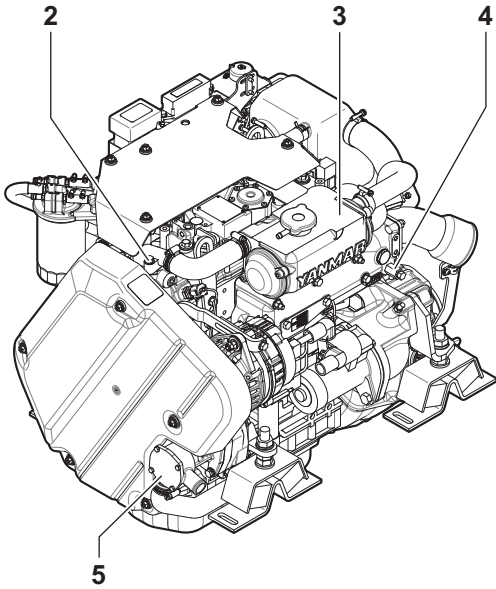

Figure 19

1 – Coolant drain cock (Cylinderblock)



108120-00X01

Figure 20

- 2 – Coolant pump
- 3 – Coolant tank (Heat exchanger)
- 4 – Coolant drain cock (Coolant tank/Heat exchanger)
- 5 – Seawater pump (Drain from pump cover)

4JH45, 4JH57

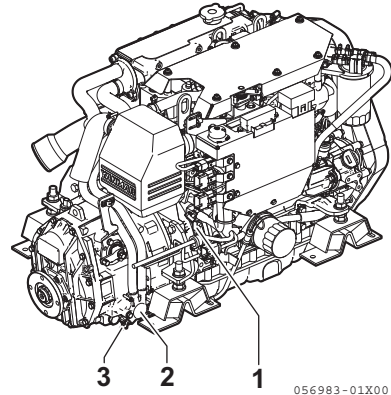

056983-01X00

Figure 21

- 1 – Coolant drain cock (Cylinderblock)
- 2 – Marine gear oil cooler (KM4A1)
- 3 – Seawater drain cock (Marine gear oil cooler)

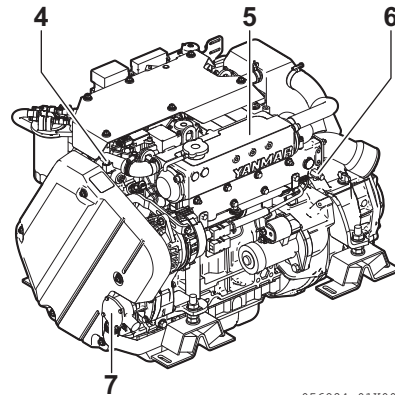

056984-01X00

Figure 22

- 4 – Coolant pump
- 5 – Coolant tank (Heat exchanger)
- 6 – Coolant drain cock (Coolant tank/Heat exchanger)
- 7 – Seawater pump (Drain from pump cover)

4JH80, 4JH110

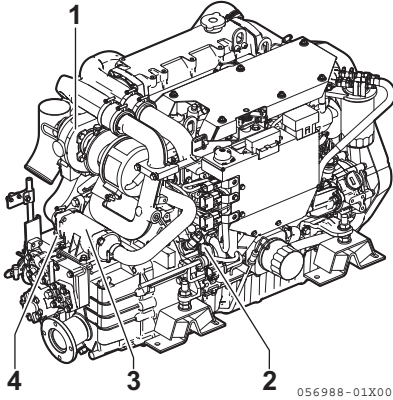

Figure 23

- 1 – Turbocharger
- 2 – Coolant drain cock
(Cylinderblock)
- 3 – Marine gear oil cooler (KMH4A)
- 4 – Seawater drain cock
(Marine gear oil cooler)

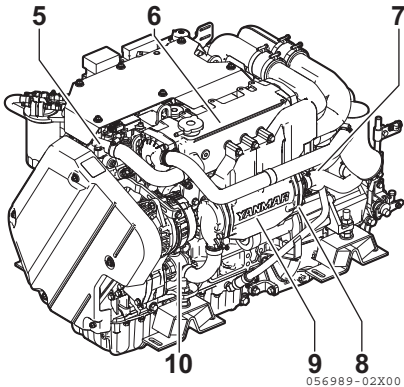

Figure 24

- 5 – Coolant pump
- 6 – Coolant tank (Heat exchanger)
- 7 – Coolant drain cock
(Coolant tank /Heat exchanger)
- 8 – Seawater drain cock (Air cooler)
- 9 – Air cooler
- 10 – Seawater pump
(Drain from pump cover)

Note: The drain cocks are opened before shipping from the factory. Marine gear ZF25A does not have a drain cock on the marine gear cooler.

1. Open all coolant drain cocks.
2. Allow to drain completely. Dispose of waste properly.
3. Close all the drain cocks.
4. Fill coolant tank and reservoir with appropriate coolant.
See Engine Coolant Specifications on page 47 and Checking and Adding Coolant on page 48 .

Cleaning the Intake Silencer (Air Cleaner) Element

1. Disassemble the intake silencer (air cleaner).
2. Remove element. Clean element and housing with a neutral detergent.
3. Dry completely and reassemble.

Cleaning the Exhaust/Water Mixing Elbow

The mixing elbow is attached to the turbocharger. The exhaust gas is mixed with seawater in the mixing elbow.

1. Remove the mixing elbow.
2. Clean dirt and scale out of the exhaust and seawater passages.
3. If the mixing elbow is damaged, repair or replace. Consult authorized Yanmar Marine dealer or distributor.
4. Inspect the gasket and replace if necessary.

PERIODIC MAINTENANCE

Wash the Turbocharger blower (If Equipped)

Contamination of the turbocharger causes revolutions to drop and engine output to fall.

If a significant drop in engine output is noted (10% or more), wash the turbocharger blower.

This should be done only by a trained and qualified technician. Consult authorized Yanmar Marine dealer or distributor.

Adjusting the Alternator V-ribbed belt Tension

See Checking and Adjusting the Alternator V-ribbed belt Tension on page 91.

Checking the Wiring Connectors

Consult authorized Yanmar Marine dealer or distributor.

Tightening All Major Nuts and Bolts

See Tightening Fasteners on page 80 or consult authorized Yanmar Marine dealer or distributor.

Every 500 Hours of Operation

Perform the following maintenance every 500 hours or 2 years of operation, whichever comes first.

- **Replacing the Exhaust/Water Mixing Elbow**
- **Replacing Rubber Hoses**

Replacing the Exhaust/Water Mixing Elbow

Replace the mixing elbow with a new one every 500 hours or 2 years, whichever comes first, even if no damage is found.

Consult authorized Yanmar Marine dealer or distributor.

Replacing Rubber Hoses

Replace rubber hoses every 2000 hours or 2 years, whichever comes first.

Consult authorized Yanmar Marine dealer or distributor.

Every 1000 Hours of Operation

Perform the following maintenance every 1000 hours or 4 years of operation, whichever comes first.

- **Replacing the Seawater Pump Impeller**
- **Cleaning and Checking the Seawater Passages**
- **Checking Diaphragm Assembly (3JH40/4JH45/4JH57 Only)**
- **Replacing the Alternator V-ribbed belt**
- **Adjusting Intake/Exhaust Valve Clearance**
- **Checking the Remote Control Cable Operation**
- **Adjusting the Propeller Shaft Alignment**

Replacing the Seawater Pump Impeller

The seawater impeller must be replaced every 1000 hours even if it is not damaged.

See Checking or Replacing Seawater Pump Impeller on page 99.

Cleaning and Checking the Seawater Passages

After prolonged use, clean the seawater passages to remove trash, scale, rust and other contaminants that collect in the seawater passages. This can cause declining cooling performance. The following items need to be inspected:

- Heat Exchanger
- Pressure Cap

Consult authorized Yanmar Marine dealer or distributor.

Checking Diaphragm Assembly (3JH40/4JH45/4JH57 Only)

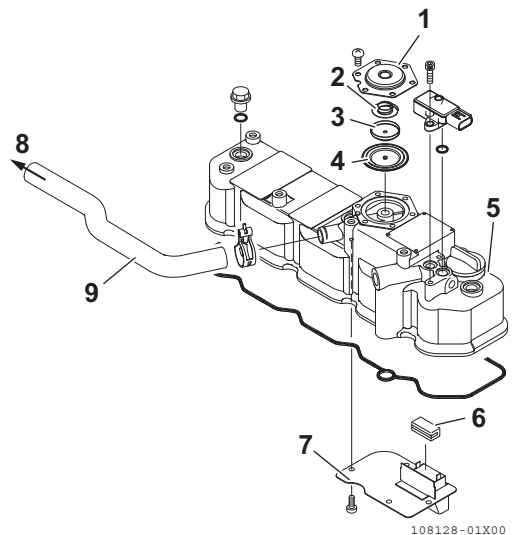

Figure 25

- 1 – Diaphragm Cover**
- 2 – Spring**
- 3 – Center Plate**
- 4 – Diaphragm**
- 5 – Rocker Arm Cover**
- 6 – Breather Baffle**
- 7 – Baffle Plate**
- 8 – Intake Silencer**
- 9 – Breather Pipe**

Consult authorized Yanmar Marine dealer or distributor.

PERIODIC MAINTENANCE

Replacing the Alternator V-ribbed belt

See Checking and Adjusting the Alternator V-ribbed belt Tension on page 91.

Adjusting Intake/Exhaust Valve Clearance

Consult authorized Yanmar Marine dealer or distributor.

Checking the Remote Control Cable Operation

Consult authorized Yanmar Marine dealer or distributor.

Adjusting the Propeller Shaft Alignment

Consult authorized Yanmar Marine dealer or distributor.

TROUBLESHOOTING

SAFETY PRECAUTIONS

Before performing any troubleshooting procedures within this section, review the *Safety section on page 3*.

If a problem occurs, stop the engine immediately. Refer to the Symptom column in the Troubleshooting Chart to identify the problem.

TROUBLESHOOTING AFTER STARTING

Just after the engine has started, check the following items at a low engine speed:

Is sufficient water being discharged from the seawater outlet pipe?

If the discharge is low, stop the engine immediately. Identify the cause and repair.

Is the smoke color normal?

The continuous emission of black exhaust smoke indicates engine overloading. This shortens the engines life and should be avoided.

Are there abnormal vibrations or noise?

Depending on the hull structure, engine and hull resonance may suddenly increase at certain engine speed ranges, causing heavy vibrations. Avoid operation in this speed range. If any abnormal sounds are heard, stop the engine and inspect for cause.

Alarm sounds during operation.

If the alarm sounds during operation, lower the engine speed immediately, check the alarm lamps and stop the engine for repairs.

TROUBLESHOOTING

Is there water, oil or fuel leakage? Are there any loose bolts or connections?

Check the engine room daily for any leaks or loose connections.

Is there sufficient fuel in the fuel tank?

Refill fuel in advance to avoid running out of fuel. If the tank runs out of fuel, bleed the fuel system. See *Bleeding the Fuel System on page 42*.

When operating the engine at low speed for long periods of time, race the engine once every 2 hours. Racing the engine with the clutch in NEUTRAL, accelerate from the low-speed position to the high-speed position and repeat this process about five times. This is done to clean out carbon from the cylinders and the fuel injection valves.

NOTICE

Neglecting to race the engine will result in poor smoke color and reduce engine performance.

Periodically operate the engine near maximum speed while underway. This will generate higher exhaust temperatures, which will help clean out hard carbon deposits, maintain engine performance and prolong the life of the engine.

TROUBLESHOOTING INFORMATION

If the engine does not operate properly, refer to the *Troubleshooting Chart on page 109* or consult authorized Yanmar Marine dealer or distributor.

Supply the authorized Yanmar Marine dealer or distributor with the following information:

- Model name and serial number of your engine
- Boat model, hull material, size (tons)
- Use, type of boating, number of hours run
- Total number of operation hours (refer to hour meter), age of boat
- The operating conditions when the problem occurs:
 - Engine speed (min⁻¹)
 - Color of exhaust smoke
 - Type of diesel fuel
 - Type of engine oil
 - Any abnormal noises or vibration
 - Operating environment such as high altitude or extreme ambient temperatures, etc.
 - Engine maintenance history and previous problems
 - Other factors that contribute to the problem

TROUBLESHOOTING CHART

Symptom	Probable Cause	Measure
Indicators light on the instrument panel and alarm sounds during operation	Shift to low speed operation immediately, and check which indicator has come on. Stop the engine and inspect. If no abnormality is identified and there is no problem with operation, return to port at lowest speed and request repairs.	
Engine does not start or starts with difficulty		
Pinion gear does not engage	Loose terminal of battery/engage magnet	Tighten
	Poor contact of starting switch	Correct with sandpaper or replace
	Open coil of magnet switch	Replace
	Burr at gear tooth tip	Correct
	Poor clearance between pinion and ring gear	Correct
Pinion gear is engaged with ring gear, but does not rotate	Loose battery/starter terminal	Tighten
	Poor contact of starting switch	Correct with sandpaper or replace
	Worn brush	Replace
	Open circuit of starter coil	Replace
	Slippage of starter/clutch	Replace
	Excessive resistance of cable between battery and starter	Increase the cable size or shorten
	Insufficient battery charge	Charge
No fuel injection	Incomplete priming of fuel system	Carry out sufficient priming
	Clogged fuel inlet filter	Replace
	Fuel level in fuel tank is low	Add fuel
	Closed cock of fuel tank	Open cock
	Clogged fuel pipe	Clean
	Failure of fuel supply pump	Repair or replace
Failure of fuel injector	Faulty valve seat	Replace
	Sticking of nozzle	Replace
	Worn nozzle	Replace
	Clogged injection hole	Replace
Failure in fuel injection system	Loose fuel injection pipe joint	Tighten
	Broken fuel injection pipe	Replace
	Air trapped in fuel injection pipe	Bleed air from pipe
Engine compressed air leak	Air leak from exhaust valve	Carry out fitting of valve and seat
	Faulty gasket/packing	Replace
	Worn upper portion of cylinder	Replace
	Worn piston ring	Replace
	Sticking piston ring	Overhaul or replace
	Broken valve spring	Replace
No revolution indication on Tachometer during cranking.	Poor connection of crank & cam position sensors.	Check connection of the wire harness
Other	Failure of engine system	Conduct servicing
	Clogged intake or exhaust pipe	Clean
	Controller defects system error	Check DTC and conduct servicing

TROUBLESHOOTING

Symptom	Probable Cause	Measure
Engine is not running smoothly		
Operation failure of injection valve	Nozzle operation failure	Replace
	Broken fuel valve spring	Replace
Uneven fuel injection quantities	Clogged fuel filter	Replace
	Faulty operation of regulator valve	Replace
	Air trapped in fuel injection system	Bleed air from system and prime system
	Faulty operation of fuel supply pump	Repair
Other	Overload operation	Reduce load
	Moving parts seized	Disassemble, inspect and conduct servicing
	Slippage of gear box	Inspect and repair
Engine stops suddenly		
No fuel feed	Fuel level in fuel tank is low	Add fuel and prime
	Air trapped in fuel system or fuel injection	Bleed air
	Water trapped in fuel tank	Drain water from drain cock and fuel pipe, conduct priming
	Fuel cock closed	Inspect and repair as necessary
	Clogged fuel filter	Replace
	Broken fuel pipe	Replace
	Failure of fuel supply pump	Replace
Other	Moving parts seized	Disassemble and repair, or replace
	Controller defects system error	Inspect DTC and conduct servicing
Abnormal smoke color		
Failure of fuel injector	Clogged injection nozzle	Replace
	Sticking needle valve	Replace
	Reduction in injection pressure	Replace
	Poor atomization	Replace
	Carbon deposit	Clean
Turbo-charger failure (If equipped)	Clogged air cleaner	Clean
	Dirty compressor side	Clean
	Clogged turbine side	Clean
	Damaged bearing	Replace
Other	Overload operation	Reduce load
	Lubricant level too high	Lower the oil level
	Accumulated carbon deposit at intake/exhaust valve	Clean
	Dirty air cooler (If equipped)	Clean
	Improper fuel	Replace with proper fuel
	Clogged intake/exhaust valve	Clean

Symptom	Probable Cause	Measure
Insufficient output		
Insufficient fuel injection	Oil leak from fuel injection pipe joint	Tighten
	Clogged fuel filter	Replace
	Clogged fuel pipe	Clean
	Failure of fuel supply pump	Repair
Insufficient injection by fuel injection nozzle	Clogged injection hole	Replace
	Faulty valve seat	Replace
	Sticking nozzle	Replace
	Loose fuel injection pipe joint	Tighten
	Worn nozzle	Replace
Compressed gas leak in the engine cylinder	Gas leak from intake/exhaust valve	Conduct fitting of the valve
	Worn upper portion of cylinder bore	Lap or replace
	Worn piston ring	Replace
	Sticking piston ring	Overhaul or replace
Turbo-charger failure (If equipped)	Clogged air cleaner	Clean
	Dirty compressor side	Clean
	Clogged turbine nozzle	Clean
	Damaged bearing	Replace
Other	Improper fuel	Replace with correct fuel
	Clogged exhaust duct	Clean
	Seized or overheated moving parts	Disassemble and conduct servicing
	Insufficient seawater	Inspect seawater pump
	Insufficient feed of engine oil	Disassemble and clean engine oil pump and filter
	Controller defects system error	Inspect DTC and conduct servicing
Knocking		
Failure of fuel injector	Broken fuel valve spring	Replace
	Sticking nozzle	Replace
	Poor atomization	Replace
Other	Insufficient seawater	Replace seawater pump impeller
	Piston clearance excessive	Replace
	Bearing clearance excessive	Replace
	Improper fuel	Replace with correct fuel
	Water trapped in fuel	Replace fuel
	Poor compression	Inspect and service

TROUBLESHOOTING

Symptom	Probable Cause	Measure	
Breakdown of turbo-charger (if equipped)			
Drop in intake pressure	Dirty air cleaner	Clean	
	Leak from intake piping	Repair	
	Leak of exhaust gas	Repair	
	High intake air temperature	Complete thermal insulation of exhaust pipe	
		Ensure intake air path is unrestricted from outside air	
		Clean air cleaner	
	Drop in air pressure in engine room	Ensure intake air path is unrestricted from outside air	
	Broken turbine impeller	Replace	
	Dirty turbine impeller	Clean	
Clogged exhaust pipe	Clean		
Abnormal vibration	Broken turbine impeller	Replace	
	Broken compressor impeller	Replace	
	Deposit of carbon or oxides on turbine	Remove and repair or replace	
	Broken bearing	Replace	
	Bent turbine shaft	Replace	
	Loose parts or fasteners	Tighten	
Noise	Damaged bearing	Replace	
	Contact by revolving parts	Repair or replace	
	Dirty or carbon deposit on turbine and compressor	Clean	
	Entrapment of foreign matter (at turbine entrance)	Repair or replace	
	Rapid change in load (surging)	Stabilize the load or replace turbine nozzle	
Quick contamination of engine oil	Gas trapped in bearing housing	Repair	
	Clogged seal air path	Clean	
	Damaged seal ring	Replace	
	Clogged pressure balance path	Clean	
Pulsation of intake air pressure	Uneven cylinder combustion	Adjust for uniform combustion	
	Rapid change in load	Operate correctly	
	Excessively dirty compressor side	Clean	
	Intake temperature too high	Clean cooling fin	
		Complete thermal insulation of exhaust pipe	
Ensure intake air path is unrestricted from outside air			
Other	Bearing seizure	Replace	
	Corrosion in compressor/turbine impeller or bearing housing	Increase the coolant temperature	
Other malfunctions			
Noise generation	Loose flywheel set bolts	Tighten bolts	
	Loose connecting rod bolts	Tighten bolts	
	Worn crank pin	Replace	
	Excessive gear backlash	Inspect the gear; replace worn gear, shaft, and/or bushing with new ones	

Symptom	Probable Cause	Measure
Low lubrication oil pressure	Clogged engine oil filter	Replace
	Engine oil temperature too high	Check the coolant level
	Failure of oil pump	Overhaul or replace
	Faulty operation of oil pump relief valve	Tighten the adjusting valve
		Replace the safety valve
	Low viscosity of engine oil used	Replace the engine oil
	Insufficient engine oil quantity	Add oil
Faulty pressure switch	Replace	
Coolant temperature too high	Insufficient seawater	Check seawater system
	Faulty thermostat	Replace
	Loose drive belt of coolant pump	Adjust the belt tension
	Overloaded operation	Decrease the load
Other	Controller defects system error	Inspect and conduct servicing

Symptom	Probable Cause	Measure	Reference
<ul style="list-style-type: none"> Water in sail drive seal indicator comes on 	Rubber sail drive seal broken.	Consult authorized Yanmar Marine dealer or distributor.	-
Indicators Do Not Go On:			
<ul style="list-style-type: none"> The tachometer does not turn on, even though the power switch is turned on 	No electrical current available. The battery switch is turned off, the fuse (3 A) on the instrument panel is burned out or the circuit is broken.	Consult authorized Yanmar Marine dealer or distributor.	-
<ul style="list-style-type: none"> One of the indicators does not go out 	Sensor switch is faulty.	Consult authorized Yanmar Marine dealer or distributor.	-
<ul style="list-style-type: none"> Battery low charge indicator does not go out during operation 	V-ribbed belt is loose or broken.	Replace V-ribbed belt or adjust tension.	<i>See Checking and Adjusting the Alternator V-ribbed belt Tension on page 91</i>
	Battery is defective.	Check battery fluid level, specific gravity or replace battery.	<i>See Checking the Battery Electrolyte Level (Serviceable Batteries Only) on page 96</i>
	Alternator power generation failure.	Consult authorized Yanmar Marine dealer or distributor.	-
<ul style="list-style-type: none"> Instrument panel does not turn on, even though the power switch is turned on 	No electrical current available. The battery switch for the engine control system is turned off, the fuse(10A) in the fuse box is burned out or the circuit is broken.	Consult authorized Yanmar Marine dealer or distributor.	-
Starting Failures:			
<ul style="list-style-type: none"> Starter does not turn or turns slowly (engine can be turned manually) 	Faulty starter relay	Consult authorized Yanmar Marine dealer or distributor.	-
	The fuse(50A) near the starter is burned out or the circuit is broken.	Consult authorized Yanmar Marine dealer or distributor.	-
	Faulty marine gear position.	Shift to NEUTRAL and start.	-
	Faulty safety switch device.	Consult authorized Yanmar Marine dealer or distributor.	-

FAILSAFE DIAGNOSIS FUNCTIONAL SPECIFICATION CHART

Failsafe Actions

Level 1 (LV1): Reduce engine speed to 2400 min⁻¹ or less

Level 2 (LV2): Reduce engine speed to 1600 min⁻¹ or less

Level 3 (LV3): Reduce engine speed to 1000 min⁻¹

Level 4 (LV4): Reduce engine speed to low idle

LCD	DTC	SPN	FMI	With FFD	DTC Description	Failsafe Action					Note
						Level 1	Level 2	Level 3	Level 4	ENG Stop	
						1	2	3	4	Stop	
CHK ENG	P000F	157	16	-	Rail Pressure Limit Valve Open	×	-	-	-	-	
CHK ENG	P0088	157	0	×	Rail Pressure Too High - Exceed the limit	×	-	-	-	-	
CHK ENG	P0093	157	15	×	Rail Pressure Deviation Error - Higher Than The Target	×	-	-	-	-	
CHK ENG	P0094	157	18	×	Rail pressure Deviation Error - Lower Than The Target	×	-	-	-	-	Suspicious Fuel Leak on the high pressure line
CHK ENG	P0117	110	4	-	Coolant Temperature Sensor Error - High Range	-	-	-	-	-	Engine is still operational.
CHK ENG	P0118	110	3	-	Coolant Temperature Sensor Error - Low Range	-	-	-	-	-	Suspicious Broken sensor or wire
AC1 ERR	P0122	91	4	-	Main Analog Throttle Sensor 1 Error - Low Range	-	-	-	-	-	One signal of the dual throttle sensor is out of limit.
AC1 ERR	P0123	91	3	-	Main Analog Throttle Sensor 1 Error - High Range	-	-	-	-	-	
AC2 ERR	P0222	28	4	-	Main Analog Throttle Sensor 2 Error - Low Range	-	-	-	-	-	
AC2 ERR	P0223	28	3	-	Main Analog Throttle Sensor 2 Error - High Range	-	-	-	-	-	
AC1 ERR AC2 ERR	P0223 P0222	91 28	4 4	-	Main Analog Throttle Sensor 1 Error - Low Range Main Analog Throttle Sensor 2 Error - Low Range	-	-	×	-	-	Both signal of the dual throttle sensor are out of limit
AC1 ERR AC2 ERR	P0123 P0122	91 28	3 3	-	Main Analog Throttle Sensor 1 Error - High Range Main Analog Throttle Sensor 2 Error - High Range	-	-	×	-	-	
CHK ENG	P0168	174	0	×	Fuel Temperature Too High	×	-	-	-	-	Suspicious insufficient fuel in the fuel tank
CHK ENG	P0182	174	4	-	Fuel Temperature Sensor Error - Low Range	-	-	-	-	-	Engine is still operational.
CHK ENG	P0183	174	3	-	Fuel Temperature Sensor Error - High Range	-	-	-	-	-	Suspicious Broken sensor or wire, poor connection
CHK ENG	P0192	157	4	-	Rail Pressure Sensor Error - Low Range	×	-	-	-	-	Suspicious Broken sensor or wire, poor connection
CHK ENG	P0193	157	3	-	Rail pressure Sensor Error - High Range	×	-	-	-	-	
CHK ENG	P0201	651	5	-	Injector 1 - Open Circuit	×	-	-	-	-	Suspicious Broken injector or wire, poor connection
CHK ENG	P0202	652	5	-	Injector 2 - Open Circuit	×	-	-	-	-	
CHK ENG	P0203	653	5	-	Injector 3 - Open Circuit	×	-	-	-	-	
CHK ENG	P0204	654	5	-	Injector 4 - Open Circuit	×	-	-	-	-	
OV HEAT	P0217	110	0	×	Engine Coolant Temperature Too High	×	-	-	-	-	
OV REV	P0219	190	0	×	Engine Overspeed Condition	-	-	-	-	×	
-	P0227	29	4	-	Sub Throttle Sensor Error - Low Range	-	-	-	-	-	(When Backup Panel is operated only)
-	P0228	29	3	-	Sub Throttle Sensor Error - High Range	-	-	-	-	-	
bOOST	P0234	102	0	×	Boost Pressure Too High	×	-	-	-	-	
CHK ENG	P0237	102	4	-	Boost Pressure Sensor Error - Low Range	-	-	-	-	-	Engine is still operational.
CHK ENG	P0238	102	3	-	Boost pressure Sensor Error - High Range	-	-	-	-	-	Suspicious Broken sensor or wire

	LCD	DTC	SPN	FMI	With FFD	DTC Description	Failsafe Action					Note
							Level 1	Level 2	Level 3	Level 4	ENG Stop	
Engine-ECU	CHK ENG	P0262	651	6	-	Injector1 Coil - Short Circuit	×	-	-	-	-	Suspicious Broken injector or wire, poor connection
	CHK ENG	P0265	652	6	-	Injector2 Coil - Short Circuit	×	-	-	-	-	
	CHK ENG	P0268	653	6	-	Injector3 Coil - Short Circuit	×	-	-	-	-	
	CHK ENG	P0271	654	6	-	Injector4 Coil - Short Circuit	×	-	-	-	-	
	CHK ENG	P0336	522400	2	-	Crankshaft Position Sensor - Irregular Signal	×	-	-	-	-	
	CHK ENG	P0337	522400	5	-	Crankshaft Position Sensor - No Signal	×	-	-	-	-	
	CHK ENG	P0341	522401	2	-	Camshaft Position Sensor - Irregular Signal	-	-	-	-	-	Engine is still operational. Suspicious Broken sensor or wire, poor connection
	CHK ENG	P0342	522401	5	-	Camshaft Position Sensor - No Signal	-	-	-	-	-	
	CHK ENG	P0541	522243	6	-	Glow relay - Short Circuit	-	-	-	-	-	Only for 3JH40
	CHK ENG	P0543	522243	5	-	Glow relay - Open Circuit	-	-	-	-	-	
	CHK ENG	P0601	630	12	-	ECU Error - EEPROM Memory Deletion	-	-	-	-	-	ECU internal failure
	CHK ENG	P0611	523492	12	-	Injector Driver IC Error	-	-	-	-	×	ECU internal failure
	CHK ENG	P0627	633	5	-	Fuel Pump - Open Circuit	-	×	-	-	-	Suspicious fuel pump failure, poor connection of wire
	CHK ENG	P0629	633	3	-	Fuel Pump - High side VB Short Circuit	-	×	-	-	-	
	CHK ENG	P062A	522572	6	-	Fuel Pump - Over Current	-	×	-	-	-	
	CHK ENG	P068A	1485	2	-	Main Relay In ECU - Early Open	-	-	-	-	-	Battery switch has been turned off before ECU has shutdown at the previous shutdown. See <i>Shutting Down the Engine</i> on page 61. Or ECU internal failure
	CHK ENG	P068B	1485	7	-	Main Relay In ECU - Stuck	-	-	-	-	-	ECU internal failure
	CHK ENG	P1004	523016	5	-	Accessory Relay - Open Circuit	-	-	-	-	-	
	CHK ENG	P1005	522778	7	-	Stop Switch - Stuck	-	-	-	-	-	
	SEAL	P1006	522775	0	-	Water In Sail drive Seal	-	-	-	-	-	
	CHK ENG	P1146	2797	6	-	Injector Bank1 - Short Circuit	×	-	-	-	(×)	3JH40: ENG Stop
	CHK ENG	P1149	2798	6	-	Injector Bank2 - Short Circuit	×	-	-	-	-	
	FUEL	P1151	522329	0	-	Water In Fuel Condition	-	-	-	-	-	
	CHK ENG	P1192	100	4	-	Oil Pressure Switch - Open Circuit	-	-	-	-	-	Suspicious Broken sensor or wire, poor connection
	OIL PRS	P1198	100	1	×	Oil Pressure Too Low	-	×	-	-	-	
	CHK ENG	P1262	651	3	-	Injector 1 - Short Circuit	×	-	-	-	(×)	Suspicious Broken injector or wire, poor connection
	CHK ENG	P1265	652	3	-	Injector 2 - Short Circuit	×	-	-	-	(×)	
	CHK ENG	P1268	653	3	-	Injector 3 - Short Circuit	×	-	-	-	(×)	
	CHK ENG	P1271	654	3	-	Injector 4 - Short Circuit	×	-	-	-	-	3JH40: ENG Stop
	CHK ENG	P1341	522401	7	-	Camshaft Position Sensor Signal - Angle Offset	-	-	-	-	-	Suspicious cam gear offset, loose installation of sensor or pulsar
	CHK ENG	P1467	523471	6	-	Starter relay coil side Short Circuit	-	-	-	-	-	
	CHK ENG	P1469	523473	12	-	ECU Error - AD Converter1	-	-	-	-	×	ECU internal failure
	CHK ENG	P1470	523474	12	-	ECU Error - AD Converter2	-	-	-	-	×	ECU internal failure
	CHK ENG	P1471	523475	12	-	ECU Error - External monitoring IC & CPU1	-	-	-	-	×	ECU internal failure
	CHK ENG	P1472	523476	12	-	ECU Error - External monitoring IC & CPU2	-	-	-	-	×	ECU internal failure
	CHK ENG	P1473	523477	12	-	ECU Error - ROM	-	-	-	-	×	ECU internal failure
	CHK ENG	P1474	523478	12	-	ECU Error - Shutoff Path1	-	-	-	-	×	Suspicious Broken injector or wire, poor connection of the wire harness to injector. Or ECU internal failure
	CHK ENG	P1475	523479	12	-	ECU Error - Shutoff Path2	-	-	-	-	×	
	CHK ENG	P1476	523480	12	-	ECU Error - Shutoff Path3	-	-	-	-	×	
	CHK ENG	P1477	523481	12	-	ECU Error - Shutoff Path4	-	-	-	-	×	
CHK ENG	P1478	523482	12	-	ECU Error - Shutoff Path5	-	-	-	-	×		
CHK ENG	P1479	523483	12	-	ECU Error - Shutoff Path6	-	-	-	-	×		
CHK ENG	P1480	523484	12	-	ECU Error - Shutoff Path7	-	-	-	-	×		
CHK ENG	P1481	523485	12	-	ECU Error - Shutoff Path8	-	-	-	-	×		
CHK ENG	P1482	523486	12	-	ECU Error - Shutoff Path9	-	-	-	-	×		
CHK ENG	P1483	523487	12	-	ECU Error - Shutoff Path10	-	-	-	-	×		

TROUBLESHOOTING

LCD	DTC	SPN	FMI	With FFD	DTC Description	Failsafe Action					Note	
						Level 1	Level 2	Level 3	Level 4	ENG Stop		
Engine-ECU	CHK ENG	P1484	523488	0	-	ECU Error - Engine Speed Recognition	-	-	-	-	×	ECU internal failure
	ALT	P1568	167	1	-	Charging System Error	-	-	-	-	-	
	CHK ENG	P1608	522588	12	-	ECU Error - Actuator Supply1 Voltage High Range	-	-	-	-	×	ECU internal failure
	CHK ENG	P1609	522590	12	-	ECU Error - Sensor Supply1 Voltage	-	-	-	-	-	ECU internal failure
	bT VOLT	P160C	158	0	-	Battery Voltage Too High	-	-	-	-	-	
	CHK ENG	P160E	522576	12	-	ECU Error - EEPROM Memory Read	-	-	-	-	-	ECU internal failure
	CHK ENG	P160F	522578	12	-	ECU Error - EEPROM Memory Write	-	-	-	-	-	ECU internal failure
	CHK ENG	P1613	522585	12	-	ECU Error - CY146 SPI Communication	-	×	-	-	-	ECU internal failure
	CHK ENG	P1617	522589	12	-	ECU Error - Actuator Supply1 Voltage Low Range	-	-	-	-	×	ECU internal failure
	CHK ENG	P1618	522591	12	-	ECU Error - Sensor Supply2 Voltage	-	-	-	-	-	ECU internal failure
	CHK ENG	P1619	522592	12	-	ECU Error - Sensor Supply3 Voltage	-	-	-	-	-	ECU internal failure
	CHK ENG	P1626	522744	4	-	ECU Error - Actuator Drive1 Short Circuit	-	-	-	-	-	ECU internal failure
	CHK ENG	P1633	522994	4	-	ECU Error - Actuator Drive2 Short Circuit	-	-	-	-	-	ECU internal failure
	bT VOLT	P1638	158	1	-	Battery Voltage Too Low	-	-	-	-	-	
	CHK ENG	P1641	522571	3	-	Fuel Pump - Low side VB Short Circuit	-	×	-	-	-	Suspicious fuel pump failure, poor connection of wire
	CHK ENG	P1642	633	6	-	Fuel Pump - High side GND Short Circuit	-	×	-	-	-	
	CHK ENG	P1643	522571	6	-	Fuel Pump - Low side GND Short Circuit	-	×	-	-	-	
	CHK ENG	P1645	522572	11	-	Fuel Pump - Over Load	-	×	-	-	-	
	CHK ENG	P1648	523462	13	-	Injector 1 - QR Code Data Error	×	-	-	-	-	Input failure of the injector correction value
	CHK ENG	P1649	523463	13	-	Injector 2 - QR Code Data Error	×	-	-	-	-	
	CHK ENG	P1650	523464	13	-	Injector 3 - QR Code Data Error	×	-	-	-	-	
	CHK ENG	P1651	523465	13	-	Injector 4 - QR Code Data Error	×	-	-	-	-	
	CHK ENG	P1665	523468	9	-	Rail Pressure Error After Pressure Limit Valve Open	-	-	-	-	×	
	CHK ENG	P1666	523469	0	-	Rail Pressure Limit Valve Open - Exceed Specified Time	-	×	-	-	-	
	CHK ENG	P1667	523470	0	-	Rail Pressure Limit Valve Error - Exceed Specified Opening Hour	-	×	-	-	-	
	CHK ENG	P1668	523489	0	-	Rail Pressure Limit Valve Error - Not Open	-	-	-	-	×	
	CHK ENG	P1669	523491	0	-	Fuel Temperature Error under Limp Home Mode	-	×	-	-	-	
	CHK ENG	P1670	523460	7	-	Double error - Rail pressure sensor and MPROP or fuel temperature sensor	-	-	-	-	×	
	CHK ENG	P2530	522308	7	-	Start Switch - Stuck	-	-	-	-	-	
	CHK ENG	U0292	522596	9	-	CAN Communication Error - TCS1	-	-	-	-	-	Suspicious Loose connection of CAN cable
CHK ENG	U0593	522596	19	-	CAN Throttle Signal Error - TCS1	-	-	-	×	-	Throttle control system error	
CHK ENG	U0593 P0228 P0227	522596 29 29	19 3 4	-	CAN Throttle Signal Error - TCS1 Sub Throttle Sensor Error - High Range or Sub Throttle Sensor Error - Low Range	-	-	×	-	-		
CHK ENG	U1304	459726	9	-	CAN Communication Error - Y_PM1	-	-	-	-	-	Suspicious Loose connection of CAN cable	
CHK ENG	U1305	459726	19	-	CAN Throttle Signal Error - Y_PM1	-	-	-	×	-	Throttle control system error	
SAFE MD	-	-	-	-	Power reduction (Engine Protection Mode)	×	×	×	×	-	Status indication under Engine Protection Mode	
ST LOCK	-	-	-	-	Starter Interlock	-	-	-	-	-	Neutral safety is active. Can not start the engine	

TROUBLESHOOTING

	LCD	DTC	SPN	FMI	With FFD	DTC Description	Failsafe Action					Note
							Level 1	Level 2	Level 3	Level 4	ENG Stop	
Engine-ECU	EMG STP	-	-	-	-	Emergency Stop	-	-	-	-	-	Emergency Stop is active. Can not start the engine
	COM ERR	-	-	-	-	Communication error between panel and engine ECU	-	-	-	-	-	Suspicious Loose connection of Extension harness. Suspicious blown fuse(20A/ECU).
Drive-ECU	-	P0920	773	3	-	SHIFT FORWARD H RANGE	-	-	-	-	-	
	-	P0920	773	4	-	SHIFT FORWARD L RANGE	-	-	-	-	-	Shift Valve (F) shuts off
	-	P0924	784	3	-	SHIFT REVERSE H RANGE	-	-	-	-	-	
	-	P0924	784	4	-	SHIFT REVERSE L RANGE	-	-	-	-	-	
	-	P0745	740	3	-	CHANGE VALVE H RANGE	-	-	-	-	-	
	-	P0745	740	4	-	CHANGE VALVE L RANGE	-	-	-	-	-	Trolling function come to be unavailable
	-	P0720	191	8	-	PROP SPEED SENSOR L RANGE	-	-	-	-	-	C-type trolling function is switched E-type
	-	P0218	177	0	-	GEAR OIL TEMP TOO HIGH	-	-	-	-	-	Trolling function come to be unavailable
	-	P0710	177	3	-	GEAR OIL TEMP H RANGE	-	-	-	-	-	
	-	P0710	177	4	-	GEAR OIL TEMP L RANGE	-	-	-	-	-	
	-	U103	525	10	-	CAN COM ERROR	-	-	-	-	-	Shift is changed to Neutral position
	Helm-ECU	-	U100	190	10	-	CAN COM ERROR ENGINE SPEED	-	-	-	-	-
-		U404	525	2	-	CAN COM ERROR SHIFT	-	-	-	-	-	Shift is changed to Neutral position
-		U402	684	2	-	CAN COM ERROR TROLLING	-	-	-	-	-	Trolling function come to be unavailable
-		P0560	158	1	-	BATTERY VOLTAGE TOO LOW	-	-	-	-	-	
-		U100	523760	9	-	CAN COM ERROR ENG-ECU TO HELM-ECU	-	-	-	×	-	Station change comes to be unavailable
-		U404	523761	9	-	CAN COM ERROR DRIVE-ECU TO HELM-ECU	-	-	-	×	-	Shift change comes to be unavailable
-		U1201	523762	9	-	CAN COM ERROR HELM-ECU TO HELM-ECU	-	-	-	×	-	Station change comes to be unavailable
-		U1202	523763	9	-	CAN COM ERROR HELM-LOCAL	-	-	-	×	-	Station change, Synch. Operation, Warmup operation, and Engine speed limit mode come to be unavailable
-		B1001	523543	4	-	NEUTRAL SW ACTIVATED	-	-	-	-	-	Station change, Synch. Operation, Warmup operation, and Engine speed limit mode come to be unavailable
-		B1002	523542	4	-	SELECT SW ACTIVATED	-	-	-	-	-	Station change and Indicator dimming operation come to be unavailable
-		B1003	523544	4	-	SYNCHRO SW ACTIVATED	-	-	-	-	-	Station change and Synchronization feature come to be unavailable
-		B1004	523545	4	-	TROLL SW ACTIVATED	-	-	-	-	-	Station change and Trolling function come to be unavailable
-	B1005	523541	3	-	START/STOP SW ACTIVATED	-	-	-	-	-	Station change comes to be unavailable	
-	P0120	91	3	-	MAIN THROTTLE SENSOR H RANGE	-	-	-	×	-	Station change and Trolling function come to be unavailable	
-	P0120	91	4	-	MAIN THROTTLE SENSOR L RANGE	-	-	-	×	-		
-	B1020	91	13	-	THROTTLE CALIBRATION INCONSISTENCY	-	-	-	×	-	Station change function come to be unavailable	
-	B1043	523768	12	-	HELM-ECU EEPROM ERROR	-	-	-	-	-	Station change comes to be unavailable	

This Page Intentionally Left Blank

LONG-TERM STORAGE

If the engine will not be used for an extended period of time, special measures should be taken to protect the cooling system, fuel system and combustion chamber from corrosion and the exterior from rusting.

The engine can normally stand idle for up to 6 months. If it remains unused for longer than this, please consult your authorized Yanmar Marine dealer or distributor.

Before performing any storage procedures within this section, review the *Safety section on page 3*.

In cold temperatures or before long-term storage, be sure to drain the seawater from the cooling system.

NOTICE

- Do not drain the coolant system. A full coolant system will prevent corrosion and frost damage.
 - If seawater is left inside of the engine, it may freeze and damage parts of the cooling system when the ambient temperature is below 0°C (32°F).
-

PREPARE ENGINE FOR LONG-TERM STORAGE

Note: If the engine is close to a periodic maintenance interval, perform those maintenance procedures before putting the engine into long-term storage.

1. Wipe off any dust or oil from the outside of engine.
2. Drain water from fuel filters.
3. Drain fuel tank completely or fill the tank to prevent condensation.
4. Grease the exposed areas and joints of the remote control cables and the bearings of the remote control handle.
5. Seal the intake silencer, exhaust pipe, etc. to prevent moisture or contamination from entering engine.
6. Completely drain bilge in hull bottom.
7. Waterproof the engine room to prevent rain or seawater from entering.
8. Charge the battery once a month to compensate for battery's self-discharge.
9. Make sure the power switch is off.

**DRAIN SEAWATER
COOLING SYSTEM**

3JH40

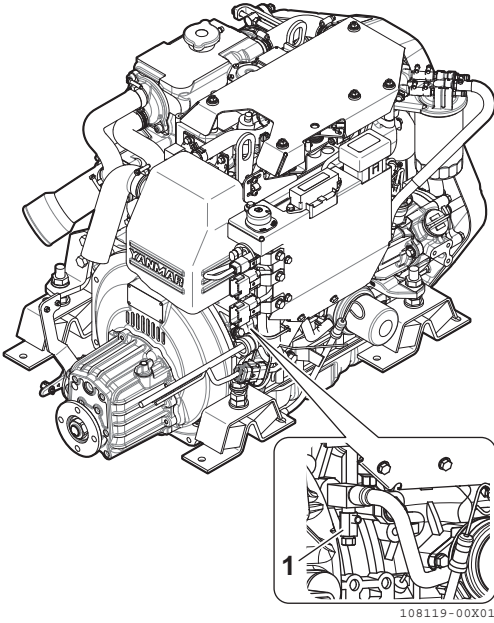

Figure 1

- 1 – Coolant drain cock
(Cylinderblock)**

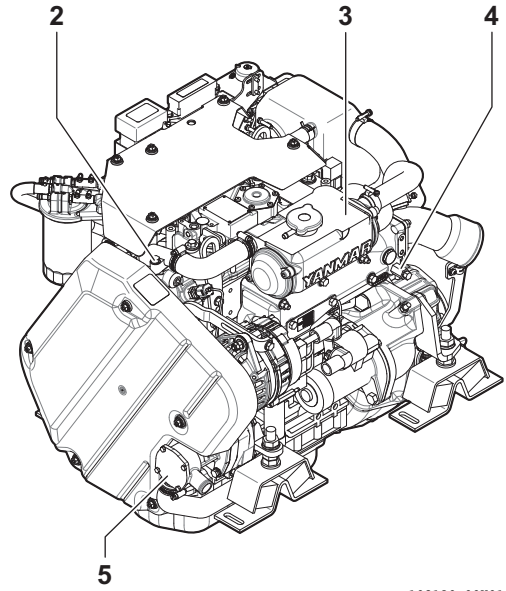

Figure 2

- 2 – Coolant pump**
- 3 – Coolant tank (Heat exchanger)**
- 4 – Coolant drain cock
(Coolant tank/Heat exchanger)**
- 5 – Seawater pump
(Drain from pump cover)**

4JH45, 4JH57

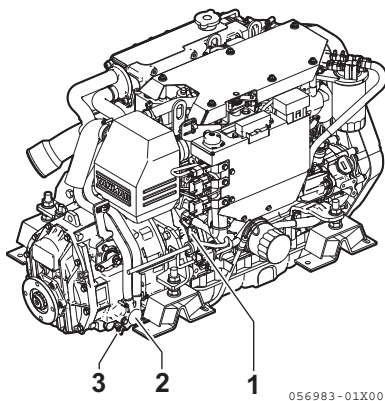

Figure 3

- 1 – Coolant drain cock
(Cylinderblock)
- 2 – Marine gear oil cooler (KM4A1)
- 3 – Seawater drain cock
(Marine gear oil cooler)

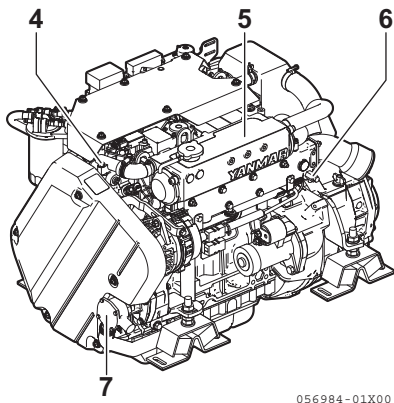

Figure 4

- 4 – Coolant pump
- 5 – Coolant tank (Heat exchanger)
- 6 – Coolant drain cock
(Coolant tank/Heat exchanger)
- 7 – Seawater pump
(Drain from pump cover)

4JH80, 4JH110

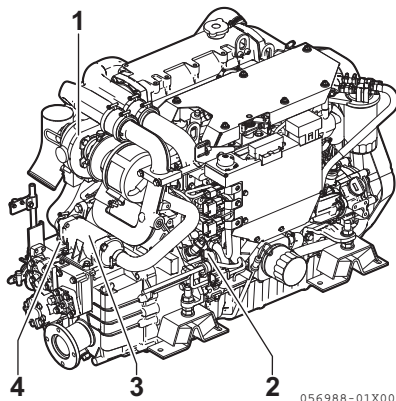

Figure 5

- 1 – Turbocharger
- 2 – Coolant drain cock
(Cylinderblock)
- 3 – Marine gear oil cooler (KMH4A)
- 4 – Seawater drain cock
(Marine gear oil cooler)

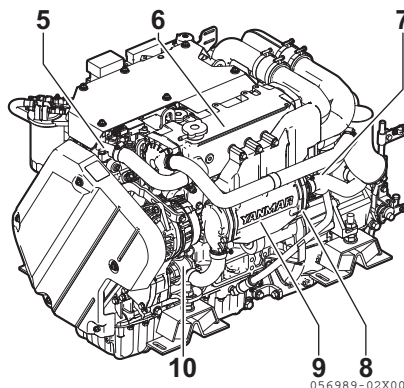

Figure 6

- 5 – Coolant pump
- 6 – Coolant tank (Heat exchanger)
- 7 – Coolant drain cock
(Coolant tank /Heat exchanger)
- 8 – Seawater drain cock
(Air cooler)
- 9 – Air cooler
- 10 – Seawater pump
(Drain from pump cover)

LONG-TERM STORAGE

Note: The drain cocks are opened before shipping from the factory. Marine gear ZF25A does not have a drain cock on the marine gear cooler.

NOTICE

If seawater is left inside, it may freeze and damage parts of the cooling system (heat exchanger, seawater pump, etc.) when ambient temperature is below 32°F (0°C).

1. Open the seawater drain cock on the marine gear cooler (if equipped). Allow to drain. Open the seawater drain cock on the air cooler (4JH80, 4JH110 only) and drain. If no water drains, use a stiff brush to remove any debris.
2. Remove four bolts attaching the side cover of the seawater pump. Remove the cover and drain the seawater.
3. Install cover and tighten bolts.
4. Close all the drain cocks.

RETURNING THE ENGINE TO SERVICE

1. Replace the oil and the oil filter before running the engine.
2. Supply fuel if the fuel in the fuel tank was removed, and prime the fuel system.
3. Confirm that there is engine coolant in the engine.
4. Operate the engine at idle speed for 1 minute.
5. Check fluid levels and check engine for leaks.

SPECIFICATIONS

PRINCIPAL ENGINE SPECIFICATIONS

SPECIFICATIONS

3JH40 Engine

Specification		3JH40			
Marine Gear Model		KM35P	KM35A	SD60	Bobtail
Use		Recreational use			
Type		Vertical water cooled 4-cycle diesel engine			
Combustion System		Direct injection			
Air Charging		Natural aspiration			
Number of Cylinders		3			
Bore x Stroke		88 mm x 90 mm (3.46 in. x 3.54 in.)			
Displacement		1.642 L (100.2 cu in.)			
Continuous power		26.8 kW (36 hp metric) / 2907 min ⁻¹			
Fuel stop power	Output at crankshaft/ engine speed	29.4 kW (40 hp metric) / 3000 min ⁻¹ *			
	Output at propeller/ engine speed	28.2 kW (38 hp metric) / 3000 min ⁻¹ *	-	-	-
Installation		Flexible mounting			
Fuel Injection Timing		Variable timing (Electronic control)			
Fuel Injection Pressure		Variable pressure (Maximum injection pressure: 150 Mpa)			
Direction of Rotation	Crankshaft	Counterclockwise viewed from stern			
	Propeller shaft (ahead)	Clockwise viewed from stern	-	-	-
Cooling System		Coolant cooling with heat exchanger			
Lubrication System		Forced lubrication system			
Cooling Water Capacity (coolant)		Engine 4.5 L (4.76 qt), Reservoir: 0.8 L (0.85 qt)			
Lubricating Oil Capacity (engine)	Rake angle	at rake angle 7°		at rake angle 0°	
	Total**	5.0 L (5.28 qt)		5.5 L (5.81 qt)	
	Oil pan only	4.5 L (4.76 qt)		5.0 L (5.28 qt)	
	Effective***	1.1 L (1.16 qt)	1.2 L (1.27 qt)		
Starting System	Type	Electric			
	Starting motor	DC 12 V - 1.4 kW			
	AC generator	12 V - 125 A			
Engine Dimension	Overall length	776 mm (30.6 in.)	774 mm (30.5 in.)	705 mm (27.8 in.)	705 mm (27.8 in.)
	Overall width	580 mm (22.8 in.)			
	Overall height	632 mm (24.9 in.)			
Engine Dry Mass (including marine gear)		204 kg (450 lb)	205 kg (452 lb)	236 kg (520 lb)	192 kg (423 lb)

* Rating Condition: Temperature of fuel; 40°C at fuel pump inlet; ISO 8665

** The "total" oil quantity includes oil in oil pan, channels, coolers and filter.

*** The effective amount of oil shows the difference in maximum scale of the dipstick and minimum scale.

Note: Density of fuel: 0.835 to 0.845 g/cm³ at 15°C. Fuel temperature at the inlet of the fuel supply pump.

Note: 1 hp metric = 0.7355 kW

3JH40 Marine Gear or Sail Drive

Model	KM35P	KM35A	SD60-5 (coupled at boat builder)
Type	Mechanical cone clutch	Mechanical cone clutch	Mechanical multiple friction disc clutch
Reduction Ratio (forward/reverse)	2.36 / 3.16 2.61 / 3.16	2.33 / 3.06 2.64 / 3.06	2.23 / 2.23 2.49 / 2.49
Propeller Speed (forward/reverse) (min ⁻¹)*	1232 / 921 1114 / 921	1246 / 955 1103 / 955	1304 / 1304 1167 / 1167
Lubrication System	Splash	Splash	Oil bath
Lubricating Oil Capacity (total)	0.5 L (0.53 qt)	0.65 L (0.69 qt)	3.1 L (3.28 qt)
Lubricating Oil Capacity (effective)	0.05 L (0.05 qt)	0.15 L (0.16 qt)	-
Cooling System	Air cooling by fan	Air cooling by fan	-
Weight	12 kg (26.5 lb)	13 kg (28.7 lb)	44 kg (97.0 lb)

* At continuous power engine speed 2907 min⁻¹

SPECIFICATIONS

4JH45 Engine

Specification		4JH45							
Marine Gear Model		KM35P	ZF30M	ZF25	KM35A2	KM4A1	ZF25A	SD60	Bobtail
Use		Recreational use							
Type		Vertical water cooled 4-cycle diesel engine							
Combustion System		Direct injection							
Air Charging		Natural aspiration							
Number of Cylinders		4							
Bore x Stroke		88 mm x 90 mm (3.46 in. x 3.54 in.)							
Displacement		2.190 L (133.6 cu in.)							
Continuous power		30.1 kW (41 hp metric) / 2907 min ⁻¹							
Fuel stop power	Output at crankshaft/ engine speed	33.1 kW (45 hp metric) / 3000 min ⁻¹ *							
	Output at propeller/ engine speed	31.8 kW (43.3 hp metric) / 3000 min ⁻¹ *					-	-	
Installation		Flexible mounting							
Fuel Injection Timing		Variable timing (Electronic control)							
Fuel Injection Pressure		Variable pressure (Maximum injection pressure: 160 Mpa)							
Direction of Rotation	Crankshaft	Counterclockwise viewed from stern							
	Propeller shaft (ahead)	Clockwise viewed from stern	Counter clockwise or clockwise (Bi-rotation)	Clockwise viewed from stern	Counterclockwise or clockwise (Bi-rotation)	-	-		
Cooling System		Coolant cooling with heat exchanger							
Lubrication System		Forced lubrication system							
Cooling Water Capacity (coolant)		Engine 6.0 L (6.34 qt), Reservoir: 0.8 L (0.85 qt)							
Lubricating Oil Capacity (engine)	Rake angle	at rake angle 7°			at rake angle 0°				
	Total**	5.0 L (5.28 qt)			5.5 L (5.81 qt)				
	Oil pan only	4.5 L (4.76 qt)			5.0 L (5.28 qt)				
	Effective***	1.4 L (1.48 qt)							
Starting System	Type	Electric							
	Starting motor	DC 12 V - 1.4 kW							
	AC generator	12 V - 125 A							
Engine Dimension	Overall length	870 mm (34.3 in.)	950 mm (37.4 in.)	990 mm (39.0 in.)	868 mm (34.2 in.)	926 mm (36.5 in.)	936 mm (36.7 in.)	802 mm (31.6 in.)	802 mm (31.6 in.)
	Overall width	589 mm (23.2 in.)							
	Overall height	627 mm (24.7 in.)							
Engine Dry Mass (including marine gear)		235 kg (518 lb)	243 kg (536 lb)	253 kg (558 lb)	236 kg (520 lb)	253 kg (558 lb)	243 kg (536 lb)	264 kg (582 lb)	220 kg (485 lb)

* Rating Condition: Temperature of fuel; 40°C at fuel pump inlet; ISO 8665

** The "total" oil quantity includes oil in oil pan, channels, coolers and filter.

*** The effective amount of oil shows the difference in maximum scale of the dipstick and minimum scale.

Note: Density of fuel: 0.835 to 0.845 g/cm³ at 15°C. Fuel temperature at the inlet of the fuel supply pump.

Note: 1 hp metric = 0.7355 kW

4JH57 Engine

Specification		4JH57							
Marine Gear Model		KM35P	ZF30M	ZF25	KM35A2	KM4A1	ZF25A	SD60	Bobtail
Use		Recreational use							
Type		Vertical water cooled 4-cycle diesel engine							
Combustion System		Direct injection							
Air Charging		Natural aspiration							
Number of Cylinders		4							
Bore x Stroke		88 mm x 90 mm (3.46 in. x 3.54 in.)							
Displacement		2.190 L (133.6 cu in.)							
Continuous power		38.1 kW (51.8 hp metric) / 2907 min ⁻¹							
Fuel stop power	Output at crankshaft/ engine speed	41.9 kW (57 hp metric) / 3000 min ⁻¹ *							
	Output at propeller/ engine speed	40.2 kW (54.7 hp metric) / 3000 min ⁻¹ *					-	-	-
Installation		Flexible mounting							
Fuel Injection Timing		Variable timing (Electronic control)							
Fuel Injection Pressure		Variable pressure (Maximum injection pressure: 160 Mpa)							
Direction of Rotation	Crankshaft	Counterclockwise viewed from stern							
	Propeller shaft (ahead)	Clockwise viewed from stern	Counter clockwise or clockwise (Bi-rotation)	Clockwise viewed from stern	Counterclockwise or clockwise (Bi-rotation)			-	-
Cooling System		Coolant cooling with heat exchanger							
Lubrication System		Forced lubrication system							
Cooling Water Capacity (coolant)		Engine 6.0 L (6.34 qt), Reservoir: 0.8 L (0.85 qt)							
Lubricating Oil Capacity (engine)	Rake angle	at rake angle 7°			at rake angle 0°				
	Total**	5.0 L (5.28 qt)			5.5 L (5.81 qt)				
	Oil pan only	4.5 L (4.76 qt)			5.0 L (5.28 qt)				
	Effective***	1.4 L (1.48 qt)							
Starting System	Type	Electric							
	Starting motor	DC 12 V - 1.4 kW							
	AC generator	12 V - 125 A							
Engine Dimension	Overall length	870 mm (34.3 in.)	950 mm (37.4 in.)	990 mm (39.0 in.)	868 mm (34.2 in.)	926 mm (36.5 in.)	936 mm (36.7 in.)	802 mm (31.6 in.)	802 mm (31.6 in.)
	Overall width	589 mm (23.2 in.)							
	Overall height	627 mm (24.7 in.)							
Engine Dry Mass (including marine gear)		235 kg (518 lb)	243 kg (536 lb)	253 kg (558 lb)	236 kg (520 lb)	253 kg (558 lb)	243 kg (536 lb)	264 kg (582 lb)	220 kg (485 lb)

* Rating Condition: Temperature of fuel; 40°C at fuel pump inlet; ISO 8665

** The "total" oil quantity includes oil in oil pan, channels, coolers and filter.

*** The effective amount of oil shows the difference in maximum scale of the dipstick and minimum scale.

Note: Density of fuel: 0.835 to 0.845 g/cm³ at 15°C. Fuel temperature at the inlet of the fuel supply pump.

Note: 1 hp metric = 0.7355 kW

SPECIFICATIONS

4JH45, 4JH57 Marine Gear or Sail Drive

Model	KM35P	ZF30M	ZF25	KM35A2	KM4A1	ZF25A	SD60-5 (coupled at boat builder)
Type	Mechanical cone clutch	Mechanical wet multiple disk clutch	Hydraulic wet multiple disk clutch	Mechanical cone clutch	Mechanical wet cone clutch	Hydraulic wet multiple disk clutch	Mechanical multiple friction disc clutch
Reduction Ratio (forward/reverse)	2.36 / 3.16 2.61 / 3.16	2.15 / 2.64 2.70 / 2.64	1.97 / 1.97 2.80 / 2.80	2.33 / 3.06 2.64 / 3.06	1.47 / 1.47 2.14 / 2.14 2.63 / 2.63	1.93 / 1.93 2.29 / 2.29 2.48 / 2.48 2.71 / 2.71	2.23 / 2.23 2.49 / 2.49
Propeller Speed (forward/reverse) (min ⁻¹)*	1232 / 921 1114 / 921	1353 / 1103 1078 / 1103	1476 / 1476 1038 / 1038	1246 / 950 1103 / 950	1983 / 1981 1360 / 1359 1106 / 1105	1506 / 1506 1269 / 1269 1172 / 1172 1073 / 1073	1304 / 1304 1167 / 1167
Lubrication System	Splash		Trochoid pump	Splash	Centrifugal pump	Trochoid pump	Oil bath
Lubricating Oil Capacity (total)	0.5 L (0.53 qt)	1.1 L (1.16 qt)**	1.8 L (1.90 qt)**	0.65 L (0.69 qt)	2.3 L (2.43 qt)	1.8 L (1.90 qt)**	2.8 L (3.0 qt) Long Reach (75 mm): 3.0 L (3.2 qt)
Lubricating Oil Capacity (effective)	0.05 L (0.05 qt)	0.2 L (0.21 qt)	-	0.15 L (0.16 qt)	0.2 L (0.21 qt)	-	-
Cooling System	Air cooling by fan	Seawater cooling		Air cooling by fan	Seawater cooling		-
Weight	15 kg (33.1 lb)	23 kg (50.7 lb)	33 kg (72.7 lb)	16 kg (35.3 lb)	33 kg (72.7 lb)	33 kg (72.7 lb)	44 kg (97.0 lb) Long Reach (75 mm): 48.2 kg (106.2 lb)

* At continuous power engine speed 2907 min⁻¹

** ZF30M, ZF25, ZF25A Lubricating oil: ATF

4JH80 Engine

Specification		4JH80						
Marine Gear Model		ZF30M	ZF25	KM4A2	KMH4A	ZF25A	SD60	Bobtail
Use		Recreational use						
Type		Vertical water cooled 4-cycle diesel engine						
Combustion System		Direct injection						
Air Charging		Turbocharged with air cooler						
Number of Cylinders		4						
Bore x Stroke		84 mm x 90 mm (3.31 in. x 3.54 in.)						
Displacement		1.995 L (121.7 cu in.)						
Continuous power		53.5 kW (72.8 hp metric) / 3101 min ⁻¹						
Fuel stop power	Output at crankshaft/ engine speed	58.8 kW (80 hp metric) / 3200 min ⁻¹ *						
	Output at propeller/ engine speed	56.4 kW (76.7 hp metric) / 3200 min ⁻¹ *					-	-
Installation		Flexible mounting						
Fuel Injection Timing		Variable timing (Electronic control)						
Fuel Injection Pressure		Variable pressure (Maximum injection pressure: 160 Mpa)						
Direction of Rotation	Crankshaft	Counterclockwise viewed from stern						
	Propeller shaft (ahead)	Clockwise viewed from stern	Counter clockwise or clockwise (Bi-rotation)				-	-
Cooling System		Coolant cooling with heat exchanger						
Lubrication System		Forced lubrication system						
Cooling Water Capacity (coolant)		Engine 7.2 L (7.61 qt), Reservoir: 0.8 L (0.85 qt)						
Lubricating Oil Capacity (engine)	Rake angle	at rake angle 7°			at rake angle 0°			
	Total**	5.5 L (5.81 qt)			6.7 L (7.08 qt)			
	Oil pan only	5.2 L (5.49 qt)			6.4 L (6.76 qt)			
	Effective***	2.4 L (2.54 qt)						
Starting System	Type	Electric						
	Starting motor	DC 12 V - 1.4 kW						
	AC generator	12 V - 125 A						
Engine Dimension	Overall length	925 mm (36.4 in.)	959 mm (37.8 in.)	909 mm (35.8 in.)	907 mm (35.7 in.)	905 mm (35.6 in.)	787 mm (31.0 in.)	787 mm (31.0 in.)
	Overall width	613 mm (24.1 in.)						
	Overall height	675 mm (26.6 in.)						
Engine Dry Mass (including marine gear)		254 kg (560 lb)	262 kg (578 lb)	263 kg (580 lb)	261 kg (575 lb)	259 kg (571 lb)	274 kg (604 lb)	229 kg (505 lb)

* Rating Condition: Temperature of fuel; 40°C at fuel pump inlet; ISO 8665

** The "total" oil quantity includes oil in oil pan, channels, coolers and filter.

*** The effective amount of oil shows the difference in maximum scale of the dipstick and minimum scale.

Note: Density of fuel: 0.835 to 0.845 g/cm³ at 15°C. Fuel temperature at the inlet of the fuel supply pump.

Note: 1 hp metric = 0.7355 kW

SPECIFICATIONS

4JH110 Engine

Specification		4JH110						
Marine Gear Model		ZF30M	ZF25	KM4A2	KMH4A	ZF25A	KMH50V	Bobtail
Use		Recreational use						
Type		Vertical water cooled 4-cycle diesel engine						
Combustion System		Direct injection						
Air Charging		Turbocharged with air cooler						
Number of Cylinders		4						
Bore x Stroke		84 mm x 90 mm (3.31 in. x 3.54 in.)						
Displacement		1.995 L (121.7 cu in.)						
Continuous power		73.6 kW (100 hp metric) / 3101 min ⁻¹						
Fuel stop power	Output at crankshaft/ engine speed	80.9 kW (110 hp metric) / 3200 min ⁻¹						
	Output at propeller/ engine speed	77.7 kW (105.7 hp metric) / 3200 min ⁻¹ *						-
Installation		Flexible mounting						
Fuel Injection Timing		Variable timing (Electronic control)						
Fuel Injection Pressure		Variable pressure (Maximum injection pressure: 160 Mpa)						
Direction of Rotation	Crankshaft	Counterclockwise viewed from stern						
	Propeller shaft (ahead)	Clockwise viewed from stern	Counterclockwise or clockwise (Bi-rotation)					-
Cooling System		Coolant cooling with heat exchanger						
Lubrication System		Forced lubrication system						
Cooling Water Capacity (coolant)		Engine 7.2 L (7.61 qt), Reservoir: 0.8 L (0.85 qt)						
Lubricating Oil Capacity (engine)	Rake angle	at rake angle 7°			at rake angle 0°			
	Total**	5.5 L (5.81 qt)			6.7 L (7.08 qt)			
	Oil pan only	5.2 L (5.49 qt)			6.4 L (6.76 qt)			
	Effective***	2.4 L (2.54 qt)						
Starting System	Type	Electric						
	Starting motor	DC 12 V - 1.4 kW						
	AC generator	12 V - 125 A						
Engine Dimension	Overall length	925 mm (36.4 in.)	959 mm (37.8 in.)	909 mm (35.8 in.)	907 mm (35.7 in.)	905 mm (35.6 in.)	1011 mm (39.8 in.)	787 mm (31.0 in.)
	Overall width	613 mm (24.1 in.)						
	Overall height	675 mm (26.6 in.)					799 mm (31.5 in.)	675 mm (26.6 in.)
Engine Dry Mass (including marine gear)		254 kg (560 lb)	262 kg (578 lb)	263 kg (580 lb)	261 kg (575 lb)	259 kg (571 lb)	305 kg (672 lb)	229 kg (505 lb)

* Rating Condition: Temperature of fuel; 40°C at fuel pump inlet; ISO 8665

** The "total" oil quantity includes oil in oil pan, channels, coolers and filter.

*** The effective amount of oil shows the difference in maximum scale of the dipstick and minimum scale.

Note: Density of fuel: 0.835 to 0.845 g/cm³ at 15°C. Fuel temperature at the inlet of the fuel supply pump.

Note: 1 hp metric = 0.7355 kW

4JH80, 4JH110 Marine Gear or Sail Drive

Model	ZF30M	ZF25	KM4A2	KMH4A	ZF25A	KMH50V*	SD60-4 (coupled at boat builder)
Type	Mechanical wet multiple disk clutch	Hydraulic wet multiple disk clutch	Mechanical wet cone clutch	Hydraulic wet multiple disk clutch		Hydraulic wet multiple disk clutch	Mechanical multiple friction disc clutch
Reduction Ratio (forward/reverse)	2.15 / 2.64 2.70 / 2.64	1.97 / 1.97 2.80 / 2.80	1.47 / 1.47 2.14 / 2.14 2.63 / 2.63	2.04 / 2.04 2.45 / 2.45	1.93 / 1.93 2.29 / 2.29 2.48 / 2.48 2.71 / 2.71	1.22 / 1.22 1.58 / 1.58 2.08 / 2.08 2.47 / 2.47	2.23 / 2.23 2.49 / 2.49
Propeller Speed (forward/reverse) (min ⁻¹ **)	1444 / 1176 1150 / 1176	1574 / 1574 1108 / 1108	2115 / 2113 1451 / 1450 1180 / 1179	1520 / 1520 1263 / 1263	1607 / 1607 1354 / 1354 1250 / 1250 1144 / 1144	2542 / 2542 1963 / 1963 1491 / 1491 1255 / 1255	1391 / 1391 1245 / 1245
Lubrication System	Splash	Trochoid pump	Centrifugal pump	Trochoid pump			Oil bath
Lubricating Oil Capacity (total)	1.1 L (1.16 qt)***	1.8 L (1.90 qt)***	3.0 L (3.17 qt)	2.0 L (2.11 qt)	1.8 L (1.90 qt)***	5.4 L (5.71 qt)	2.8 L (3.0 qt) Long Reach (75 mm): 3.0 L (3.2 qt)
Lubricating Oil Capacity (effective)	0.2 L (0.21 qt)	-	0.3 L (0.32 qt)	0.2 L (0.21 qt)	-	-	-
Cooling System	Seawater cooling						-
Weight	25 kg (55.1 lb)	33 kg (72.7 lb)	33 kg (72.7 lb)	32 kg (70.5 lb)	33 kg (72.7 lb)	69 kg (152.1 lb)	45 kg (99.0 lb) Long Reach (75 mm): 49.7 kg (109.6 lb)

* KMH50V: Only for 4JH110







** At continuous power engine speed 3101 min⁻¹

*** ZF30M, ZF25, ZF25A Lubricating oil: ATF

This Page Intentionally Left Blank

SYSTEM DIAGRAMS

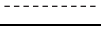
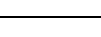
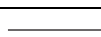
PIPING DIAGRAMS

Notation	Description
	Screw Joint (Union)
	Flange Joint
	Eye Joint
	Insertion Joint
	Drilled Hole
	Coolant Piping
	Cooling Seawater Piping
	Lubricating Oil Piping
	Diesel Fuel Piping

Note:

- Dimension of steel pipe: outer diameter x thickness.
- Dimension of rubber pipe: inner diameter x thickness.
- Fuel rubber pipes (marked *) satisfy EN/ISO7840.

3JH40 with KM35P or KM35A or SD60 Marine Gear

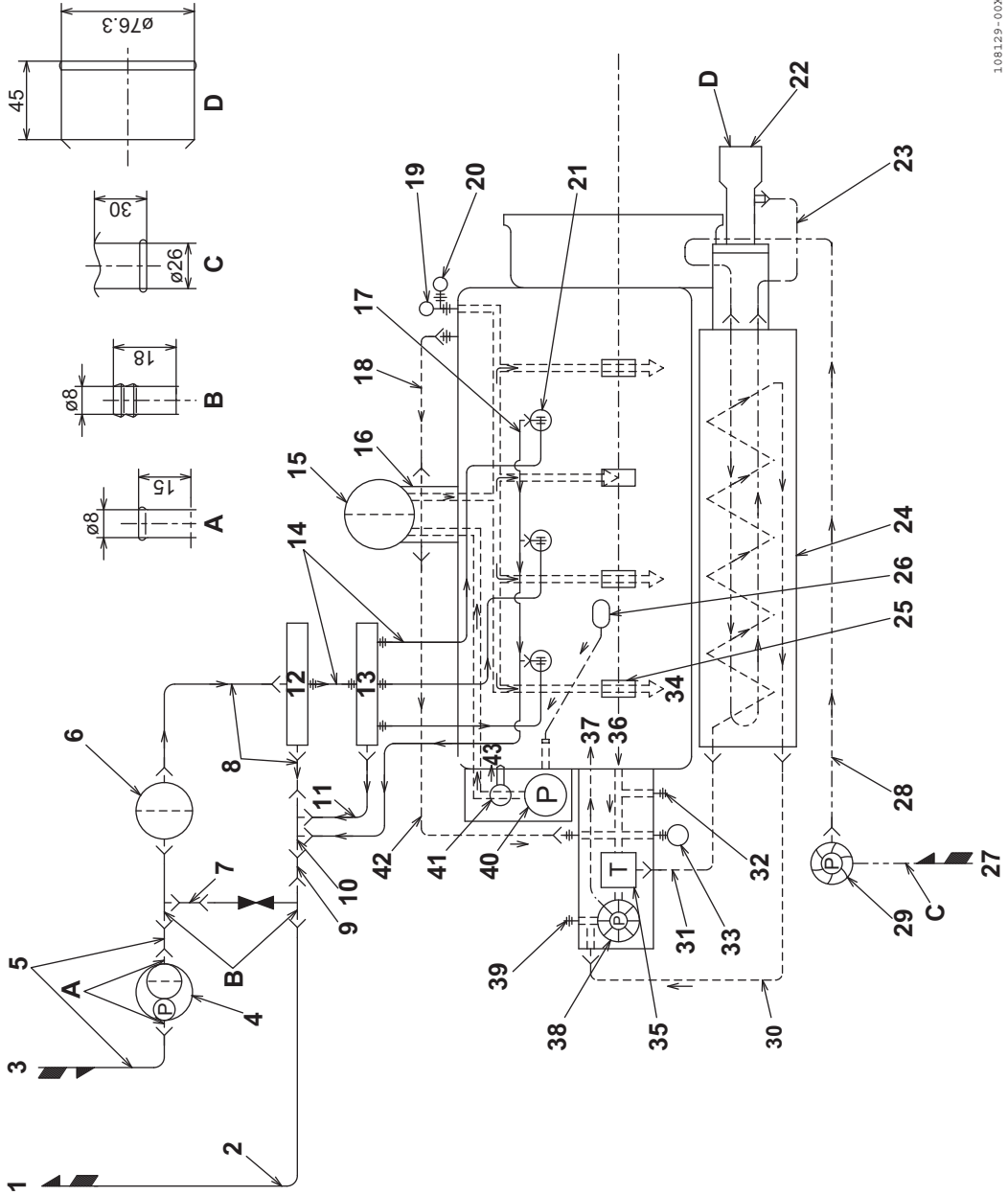

1.08129-00X00

Figure 1

- 1 – Fuel overflow
- 2 – * 7 x t4.5 Rubber hose
- 3 – Fuel inlet
- 4 – Fuel oil pre-filter
- 5 – * 7 x t4.5 Rubber hose
- 6 – Fuel filter (cartridge type)
- 7 – * 7.5 x t3 Rubber hose
- 8 – * 9.5 x t3.5 Rubber hose
- 9 – * 9.5 x t3.5 Rubber hose
- 10 – * 10 x t1.2 Steel pipe
- 11 – * 7.5 x t3 Rubber hose
- 12 – Fuel supply pump
- 13 – Common rail
- 14 – Fuel high-pressure pipe 6.35 x
t1.675 Steel pipe
- 15 – Lubricating oil filter
(cartridge type)
- 16 – Lubricating oil cooler
- 17 – Fuel return pipe
- 18 – 9 x t3.5 Rubber hose
- 19 – Oil pressure switch
- 20 – Oil pressure sensor
- 21 – Fuel injector
- 22 – Mixing elbow
- 23 – 25.4 x t4.3 Rubber hose
- 24 – Heat exchanger
- 25 – Main bearing
- 26 – Lubrication oil inlet strainer
- 27 – Seawater inlet
- 28 – 25.4 x t4.3 Rubber hose
- 29 – Cooling water pump (seawater)
- 30 – 28 x t4 Rubber hose
- 31 – 28 x t4 Rubber hose
- 32 – Hot water connection outlet
- 33 – Coolant temperature sensor
- 34 – To Camshaft
- 35 – Thermostat
- 36 – From Cylinderhead
- 37 – To Cylinderblock
- 38 – Cooling Water Pump (coolant)
- 39 – Hot water connection return
- 40 – Lubrication oil pump
- 41 – Lubrication oil pressure
control valve
- 42 – 9 x t3.5 Rubber hose
- 43 – To Oil pan

SYSTEM DIAGRAMS

4JH45/4JH57 with KM35P or KM35A2 or SD60 Marine Gear

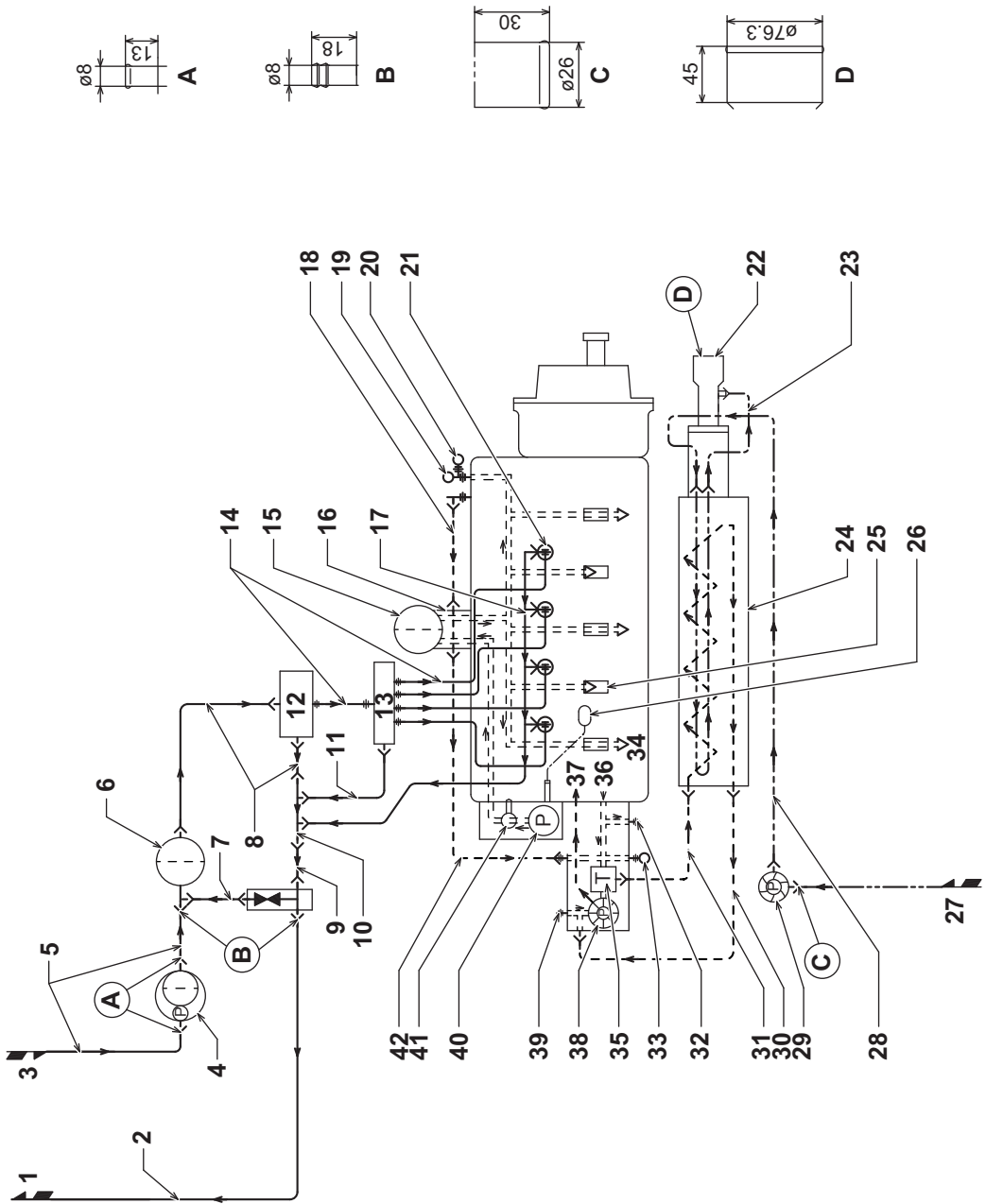

057225-00X00

Figure 2

- 1 – Fuel overflow
- 2 – * 7 x t4.5 Rubber hose
- 3 – Fuel inlet
- 4 – Fuel oil pre-filter
- 5 – * 7 x t4.5 Rubber hose
- 6 – Fuel filter (cartridge type)
- 7 – * 7.5 x t3 Rubber hose
- 8 – * 9.5 x t3.5 Rubber hose
- 9 – * 9.5 x t3.5 Rubber hose
- 10 – * 10 x t1.2 Steel pipe
- 11 – * 7.5 x t3 Rubber hose
- 12 – Fuel supply pump
- 13 – Common rail
- 14 – Fuel high-pressure pipe 6.35 x
t1.675 Steel pipe
- 15 – Lubricating oil filter
(cartridge type)
- 16 – Lubricating oil cooler
- 17 – Fuel return pipe
- 18 – 9 x t3.5 Rubber hose
- 19 – Oil pressure switch
- 20 – Oil pressure sensor
- 21 – Fuel injector
- 22 – Mixing elbow
- 23 – 25.4 x t4.3 Rubber hose
- 24 – Heat exchanger
- 25 – Main bearing
- 26 – Lubrication oil inlet strainer
- 27 – Seawater inlet
- 28 – 25.4 x t4.3 Rubber hose
- 29 – Cooling water pump (seawater)
- 30 – 28 x t4 Rubber hose
- 31 – 28 x t4 Rubber hose
- 32 – Hot water connection outlet
- 33 – Coolant temperature sensor
- 34 – To Camshaft
- 35 – Thermostat
- 36 – From Cylinderhead
- 37 – To Cylinderblock
- 38 – Cooling Water Pump (coolant)
- 39 – Hot water connection return
- 40 – Lubrication oil pump
- 41 – Lubrication oil pressure
control valve
- 42 – 9 x t3.5 Rubber hose

4JH45/4JH57 with KM4A1 Marine Gear

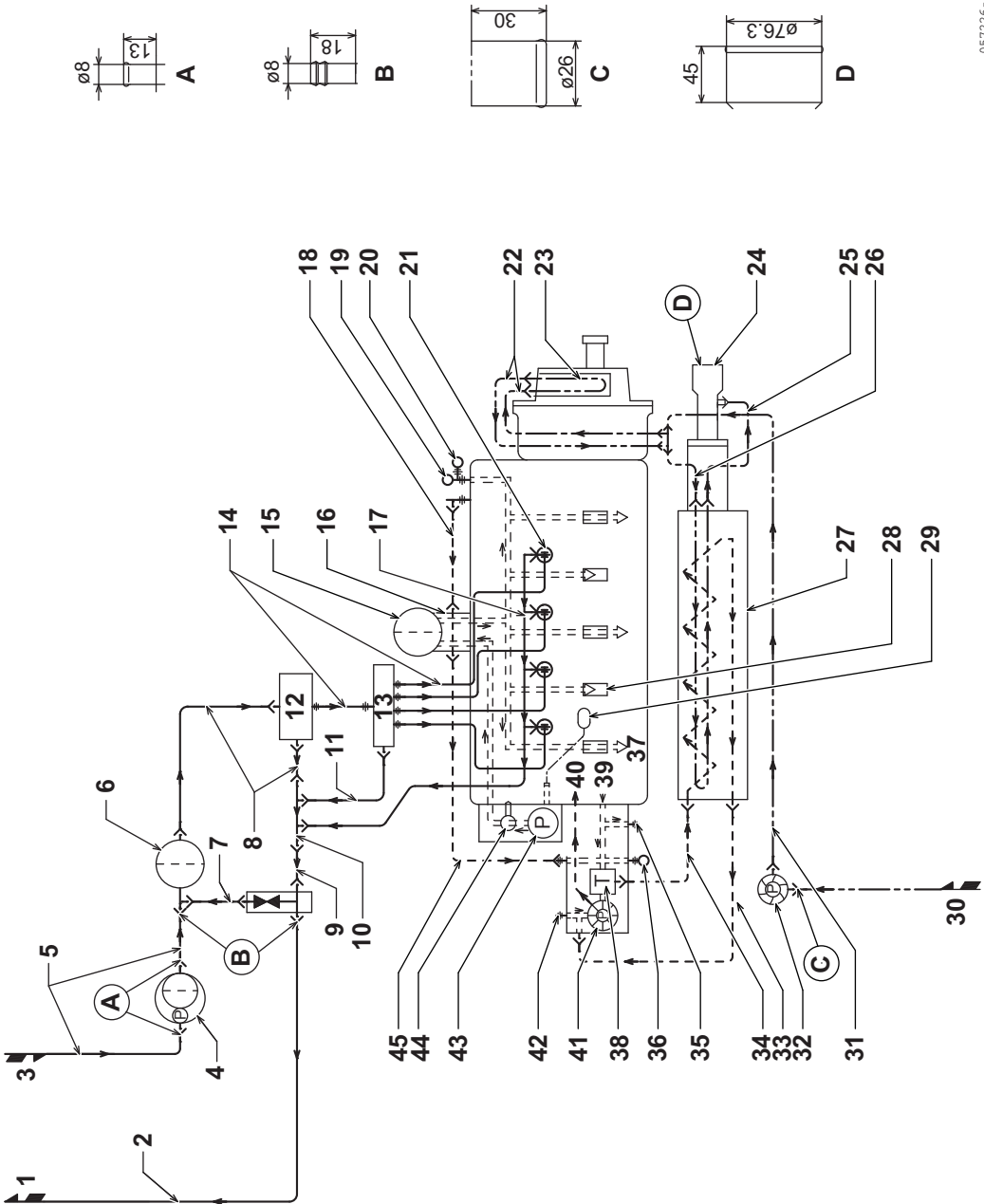

057226-00X00

Figure 3

- 1 – Fuel overflow
- 2 – * 7 x t4.5 Rubber hose
- 3 – Fuel inlet
- 4 – Fuel oil pre-filter
- 5 – * 7 x t4.5 Rubber hose
- 6 – Fuel filter (cartridge type)
- 7 – * 7.5 x t3 Rubber hose
- 8 – * 9.5 x t3.5 Rubber hose
- 9 – * 9.5 x t3.5 Rubber hose
- 10 – * 10 x t1.2 Steel pipe
- 11 – * 7.5 x t3 Rubber hose
- 12 – Fuel supply pump
- 13 – Common rail
- 14 – Fuel high-pressure pipe 6.35 x
t1.675 Steel pipe
- 15 – Lubricating oil filter
(cartridge type)
- 16 – Lubricating oil cooler
- 17 – Fuel return pipe
- 18 – 9 x t3.5 Rubber hose
- 19 – Oil pressure switch
- 20 – Oil pressure sensor
- 21 – Fuel injector
- 22 – 13 x t4 Rubber hose
- 23 – Marine gear lubrication oil
Cooler
- 24 – Mixing elbow
- 25 – 25.4 x t4.3 Rubber hose
- 26 – 25.4 x t4.3 Rubber hose
- 27 – Heat exchanger
- 28 – Main bearing
- 29 – Lubrication oil inlet strainer
- 30 – Seawater inlet
- 31 – 25.4 x t4.3 Rubber hose
- 32 – Cooling water pump (seawater)
- 33 – 28 x t4 Rubber hose
- 34 – 28 x t4 Rubber hose
- 35 – Hot water connection outlet
- 36 – Coolant temperature sensor
- 37 – To Camshaft
- 38 – Thermostat
- 39 – From Cylinderhead
- 40 – To Cylinderblock
- 41 – Cooling Water Pump (coolant)
- 42 – Hot water connection return
- 43 – Lubrication oil pump
- 44 – Lubrication oil pressure
control valve
- 45 – 9 x t3.5 Rubber hose

4JH45/4JH57 with ZF30M Marine Gear

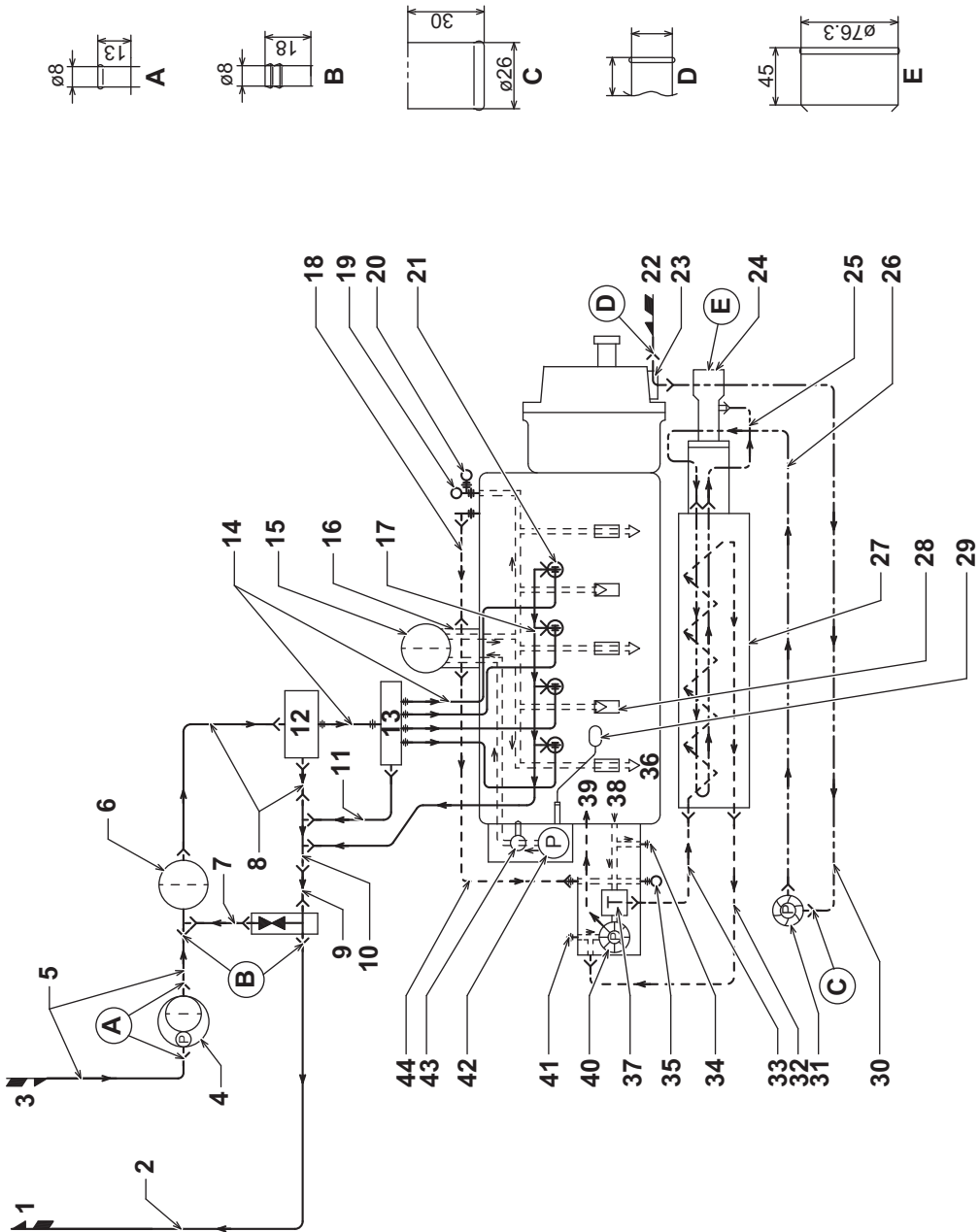
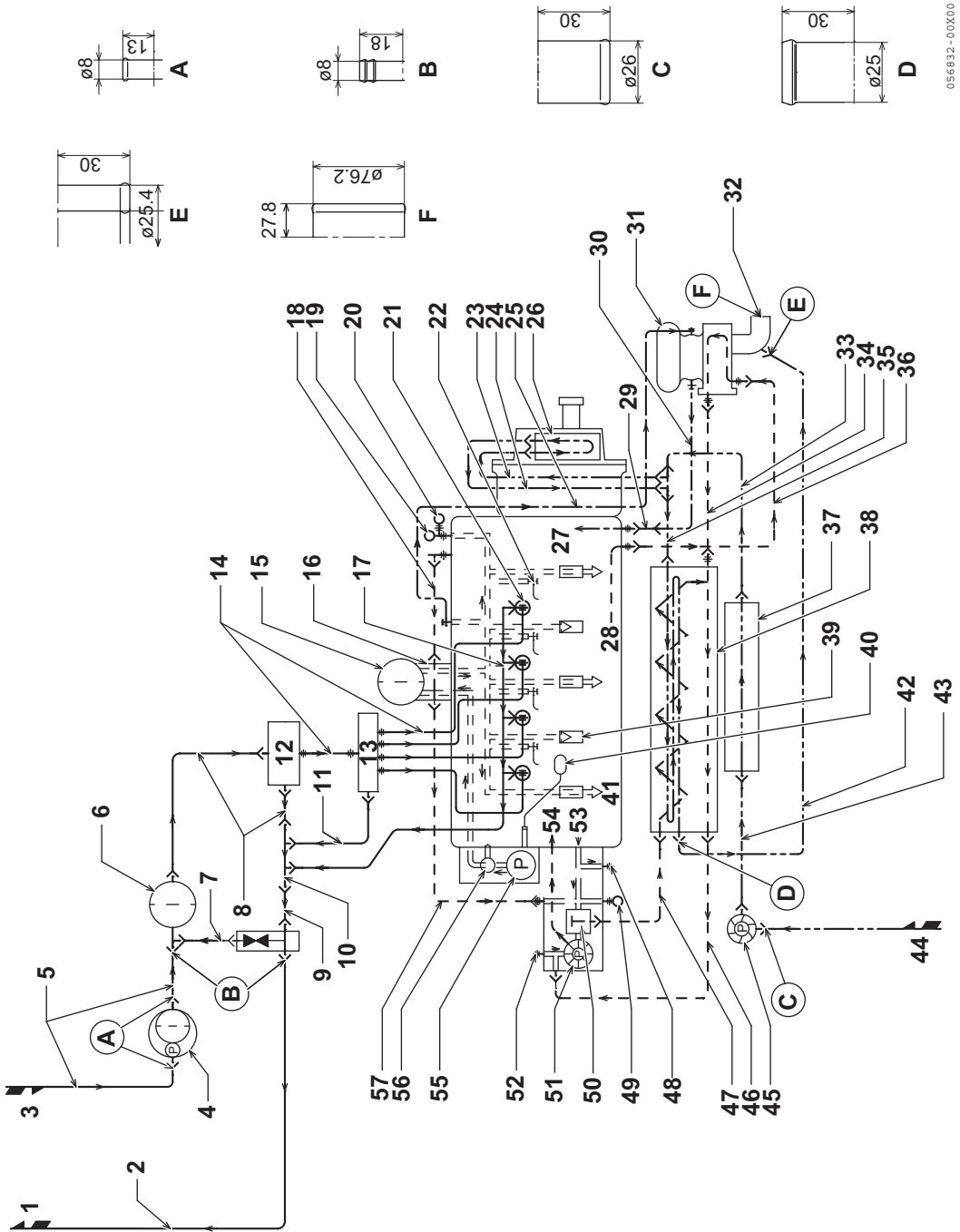

Figure 4

057227-00X00

- 1 – Fuel overflow
- 2 – * 7 x t4.5 Rubber hose
- 3 – Fuel inlet
- 4 – Fuel oil pre-filter
- 5 – * 7 x t4.5 Rubber hose
- 6 – Fuel filter (cartridge type)
- 7 – * 7.5 x t3 Rubber hose
- 8 – * 9.5 x t3.5 Rubber hose
- 9 – * 9.5 x t3.5 Rubber hose
- 10 – * 10 x t1.2 Steel pipe
- 11 – * 7.5 x t3 Rubber hose
- 12 – Fuel supply pump
- 13 – Common rail
- 14 – Fuel high-pressure pipe 6.35 x
t1.675 Steel pipe
- 15 – Lubricating oil filter
(cartridge type)
- 16 – Lubricating oil cooler
- 17 – Fuel return pipe
- 18 – 9 x t3.5 Rubber hose
- 19 – Oil pressure switch
- 20 – Oil pressure sensor
- 21 – Fuel injector
- 22 – Seawater inlet
- 23 – Marine gear lubrication oil
Cooler
- 24 – Mixing elbow
- 25 – 25.4 x t4.3 Rubber hose
- 26 – 25.4 x t4.3 Rubber hose
- 27 – Heat exchanger
- 28 – Main bearing
- 29 – Lubrication oil inlet strainer
- 30 – 25.4 x t4.3 Rubber hose
- 31 – Cooling water pump (seawater)
- 32 – 28 x t4 Rubber hose
- 33 – 28 x t4 Rubber hose
- 34 – Hot water connection outlet
- 35 – Coolant temperature sensor
- 36 – To Camshaft
- 37 – Thermostat
- 38 – From Cylinderhead
- 39 – To Cylinderblock
- 40 – Cooling Water Pump (coolant)
- 41 – Hot water connection return
- 42 – Lubrication oil pump
- 43 – Lubrication oil pressure
control valve
- 44 – 9 x t3.5 Rubber hose

4JH80/4JH110 with KM4A2 Marine Gear



056832-00X00

Figure 5

- 1 – Fuel overflow
- 2 – * 7 x t4.5 Rubber hose
- 3 – Fuel inlet
- 4 – Fuel oil pre-filter
- 5 – * 7 x t4.5 Rubber hose
- 6 – Fuel filter (cartridge type)
- 7 – * 7.5 x t3 Rubber hose
- 8 – * 9.5 x t3.5 Rubber hose
- 9 – * 9.5 x t3.5 Rubber hose
- 10 – * 10 x t1.2 Steel pipe
- 11 – * 7.5 x t3 Rubber hose
- 12 – Fuel supply pump
- 13 – Common rail
- 14 – Fuel high-pressure pipe 6.35 x t1.675 Steel pipe
- 15 – Lubricating oil filter (cartridge type)
- 16 – Lubricating oil cooler
- 17 – Fuel return pipe
- 18 – 13 x t3.5 Rubber hose
- 19 – Oil pressure switch
- 20 – Oil pressure sensor
- 21 – Fuel injector
- 22 – Piston cooling oil jet
- 23 – 13 x t4 Rubber hose
- 24 – 13 x t4 Rubber hose
- 25 – 8 x t1 STKM
- 26 – Marine gear lubrication oil Cooler
- 27 – To Oil pan
- 28 – From Cylinder block
- 29 – 17 x t3 rubber hose
- 30 – 17 x t1.2 STKM
- 31 – Turbo charger
- 32 – Mixing elbow
- 33 – 25.4 x t4.3 Rubber hose
- 34 – 8.5 x t3.5 Rubber hose
- 35 – 25.4 x t4.3 Rubber hose
- 36 – 7.5 x t2.5 Rubber hose
- 37 – Air cooler
- 38 – Heat exchanger
- 39 – Main bearing
- 40 – Lubrication oil inlet strainer
- 41 – To Camshaft
- 42 – 25.4 x t4.3 Rubber hose (option)
- 43 – 25.4 x t4.3 Rubber hose
- 44 – Seawater inlet
- 45 – Cooling water pump (seawater)
- 46 – 28 x t4 Rubber hose
- 47 – 28 x t4 Rubber hose
- 48 – Hot water connection outlet
- 49 – Coolant temperature sensor
- 50 – Thermostat
- 51 – Cooling Water Pump (coolant)
- 52 – Hot water connection return
- 53 – From Cylinderhead
- 54 – To Cylinderblock
- 55 – Lubrication oil pump
- 56 – Lubrication oil pressure control valve
- 57 – 15 x t3.5 Rubber hose

SYSTEM DIAGRAMS

4JH80/4JH110 with KMH4A or KMH50V or ZF25A or ZF25 Marine Gear

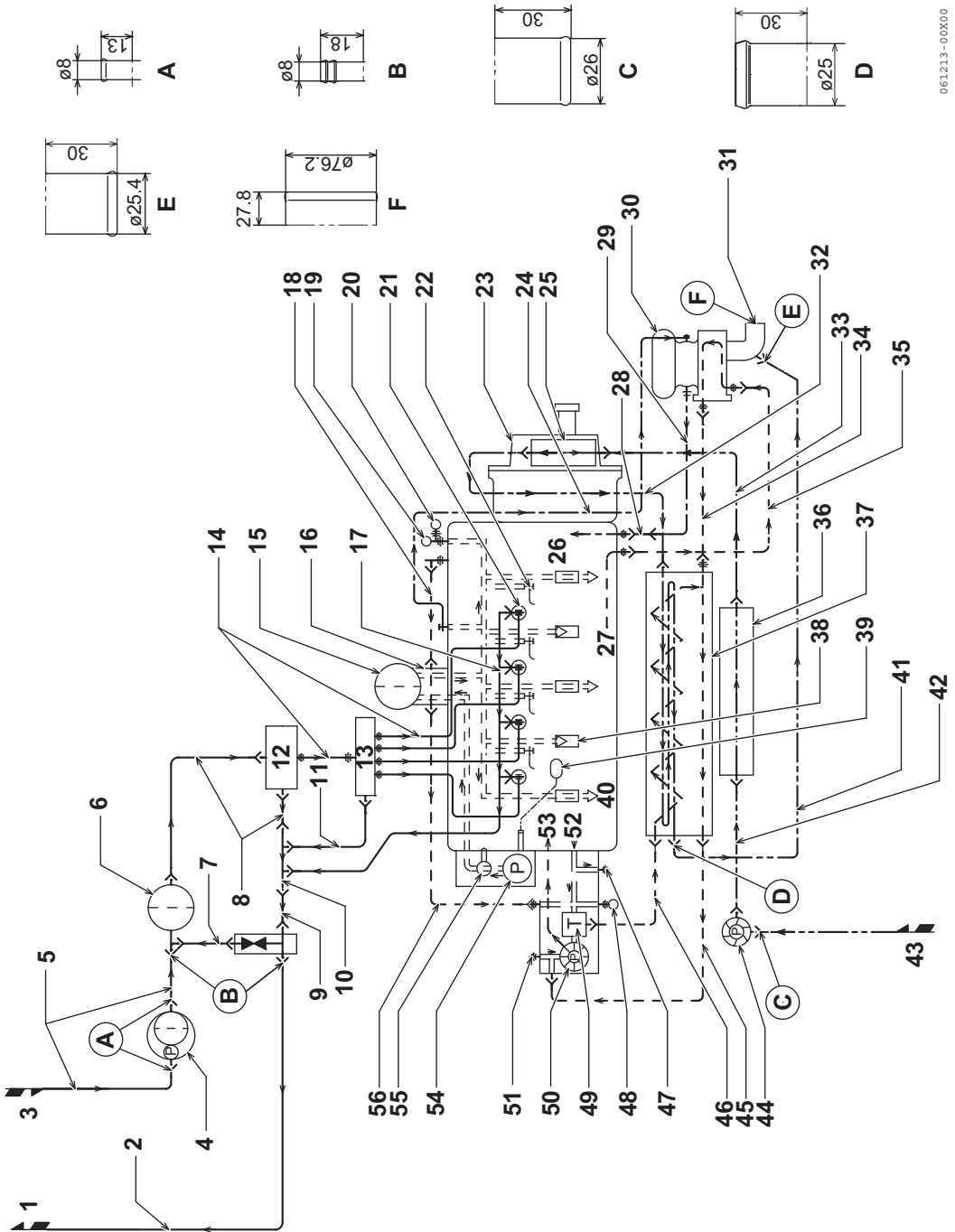

061213-00X00

Figure 6

- 1 – Fuel overflow
- 2 – * 7 x t4.5 Rubber hose
- 3 – Fuel inlet
- 4 – Fuel oil pre-filter
- 5 – * 7 x t4.5 Rubber hose
- 6 – Fuel filter (cartridge type)
- 7 – * 7.5 x t3 Rubber hose
- 8 – * 9.5 x t3.5 Rubber hose
- 9 – * 9.5 x t3.5 Rubber hose
- 10 – * 10 x t1.2 Steel pipe
- 11 – * 7.5 x t3 Rubber hose
- 12 – Fuel supply pump
- 13 – Common rail
- 14 – Fuel high-pressure pipe 6.35 x t1.675 Steel pipe
- 15 – Lubricating oil filter (cartridge type)
- 16 – Lubricating oil cooler
- 17 – Fuel return pipe
- 18 – 13 x t3.5 Rubber hose
- 19 – Oil pressure switch
- 20 – Oil pressure sensor
- 21 – Fuel injector
- 22 – Piston cooling oil jet
- 23 – Marine gear
- 24 – 8 x t1 STKM
- 25 – Marine gear lubrication oil Cooler
- 26 – To Oil pan
- 27 – From Cylinder block
- 28 – 17 x t3 rubber hose
- 29 – 17 x t1.2 STKM
- 30 – Turbo charger
- 31 – Mixing elbow
- 32 – 25. x t4.5 Rubber hose
- 33 – 25. x t4.5 Rubber hose
- 34 – 8.5 x t3.5 Rubber hose
- 35 – 7.5 x t2.5 Rubber hose
- 36 – Air cooler
- 37 – Heat exchanger
- 38 – Main bearing
- 39 – Lubrication oil inlet strainer
- 40 – To Camshaft
- 41 – 25.4 x t5 Rubber hose (option)
- 42 – 25. x t4.5 Rubber hose
- 43 – Seawater inlet
- 44 – Cooling water pump (seawater)
- 45 – 28 x t4 Rubber hose
- 46 – 28 x t4 Rubber hose
- 47 – Hot water connection outlet
- 48 – Coolant temperature sensor
- 49 – Thermostat
- 50 – Cooling Water Pump (coolant)
- 51 – Hot water connection return
- 52 – From Cylinderhead
- 53 – To Cylinderblock
- 54 – Lubrication oil pump
- 55 – Lubrication oil pressure control valve
- 56 – 15 x t3.5 Rubber hose

4JH80/4JH110 with ZF30M Marine Gear

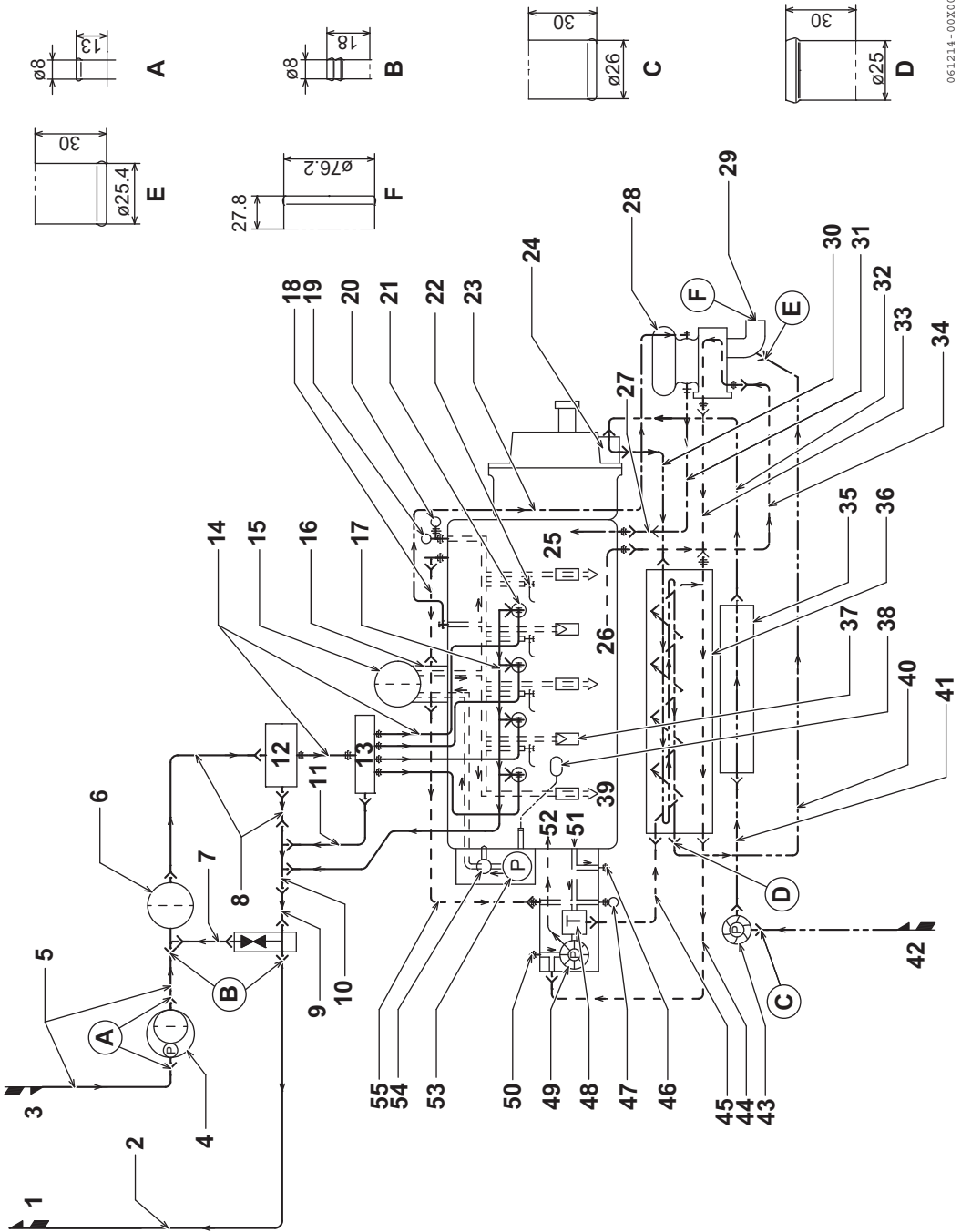

061214-00X00

Figure 7

- | | |
|-------------------------------------------------------------------------------------------------------------------------------------------------------------------------------------------------------------------------------------------------------------------------------------------------------------------------------------------------------------------------------------------------------------------------------------------------------------------------------------------------------------------------------------------------------------------------------------------------------------------------------------------------------------------------------------------------------------------------------------------------------------------------------------------------------------------------------------------------------------------------------------------------------------------------------------------------------------------------------------------------------------------------------------------------------------------------------------------------------------------------------------------------------------------------------------------------------------------------------------------------------------------------------------------------------------------------------------------------------------------------------------------------------------------------------------------------------------------------------------------------------------------------------------------------------------------------------|---------------------------------------------------------------------------------------------------------------------------------------------------------------------------------------------------------------------------------------------------------------------------------------------------------------------------------|
| <p>1 – Fuel overflow</p> <p>2 – * 7 x t4.5 Rubber hose</p> <p>3 – Fuel inlet</p> <p>4 – Fuel oil pre-filter</p> <p>5 – * 7 x t4.5 Rubber hose</p> <p>6 – Fuel filter (cartridge type)</p> <p>7 – * 7.5 x t3 Rubber hose</p> <p>8 – * 9.5 x t3.5 Rubber hose</p> <p>9 – * 9.5 x t3.5 Rubber hose</p> <p>10 – * 10 x t1.2 Steel pipe</p> <p>11 – * 7.5 x t3 Rubber hose</p> <p>12 – Fuel supply pump</p> <p>13 – Common rail</p> <p>14 – Fuel high-pressure pipe 6.35 x t1.675 Steel pipe</p> <p>15 – Lubricating oil filter (cartridge type)</p> <p>16 – Lubricating oil cooler</p> <p>17 – Fuel return pipe</p> <p>18 – 13 x t3.5 Rubber hose</p> <p>19 – Oil pressure switch</p> <p>20 – Oil pressure sensor</p> <p>21 – Fuel injector</p> <p>22 – Piston cooling oil jet</p> <p>23 – 8 x t1 STKM</p> <p>24 – Marine gear lubrication oil Cooler</p> <p>25 – To Oil pan</p> <p>26 – From Cylinder block</p> <p>27 – 17 x t3 rubber hose</p> <p>28 – Turbo charger</p> <p>29 – Mixing elbow</p> <p>30 – 25 x t4.5 Rubber hose</p> <p>31 – 17 x t1.2 STKM</p> <p>32 – 25 x t4.5 Rubber hose</p> <p>33 – 8.5 x t3.5 Rubber hose</p> <p>34 – 7.5 x t2.5 Rubber hose</p> <p>35 – Air cooler</p> <p>36 – Heat exchanger</p> <p>37 – Main bearing</p> <p>38 – Lubrication oil inlet strainer</p> <p>39 – To Camshaft</p> <p>40 – 25.4 x t5 Rubber hose (option)</p> <p>41 – 25. x t4.5 Rubber hose</p> <p>42 – Seawater inlet</p> <p>43 – Cooling water pump (seawater)</p> <p>44 – 28 x t4 Rubber hose</p> <p>45 – 28 x t4 Rubber hose</p> <p>46 – Hot water connection outlet</p> | <p>47 – Coolant temperature sensor</p> <p>48 – Thermostat</p> <p>49 – Cooling Water Pump (coolant)</p> <p>50 – Hot water connection return</p> <p>51 – From Cylinderhead</p> <p>52 – To Cylinderblock</p> <p>53 – Lubrication oil pump</p> <p>54 – Lubrication oil pressure control valve</p> <p>55 – 15 x t3.5 Rubber hose</p> |
|-------------------------------------------------------------------------------------------------------------------------------------------------------------------------------------------------------------------------------------------------------------------------------------------------------------------------------------------------------------------------------------------------------------------------------------------------------------------------------------------------------------------------------------------------------------------------------------------------------------------------------------------------------------------------------------------------------------------------------------------------------------------------------------------------------------------------------------------------------------------------------------------------------------------------------------------------------------------------------------------------------------------------------------------------------------------------------------------------------------------------------------------------------------------------------------------------------------------------------------------------------------------------------------------------------------------------------------------------------------------------------------------------------------------------------------------------------------------------------------------------------------------------------------------------------------------------------|---------------------------------------------------------------------------------------------------------------------------------------------------------------------------------------------------------------------------------------------------------------------------------------------------------------------------------|

This Page Intentionally Left Blank

WIRING DIAGRAMS

Color Coding	
B	Black
R	Red
L	Blue
W	White
G	Green
Gr	Gray
Y	Yellow
Br	Brown
O	Orange
Lg	Light green
P	Pink
V	Purple

Allowable Length by Cross Sectional Area of Battery Cable	
Section of Cable mm ² (in. ²)	Allowable Length L = 1 + 2 + 3 m (ft)
15 (0.023)	< 0.86 (2.8)
20 (0.031)	< 1.3 (4.3)
30 (0.046)	< 2.3 (7.5)
40 (0.062)	< 2.8 (9.1)
50 (0.077)	< 3.5 (11.5)
60 (0.093)	< 4.1 (13.5)

Standard (B25,C35-Type instrument panel)

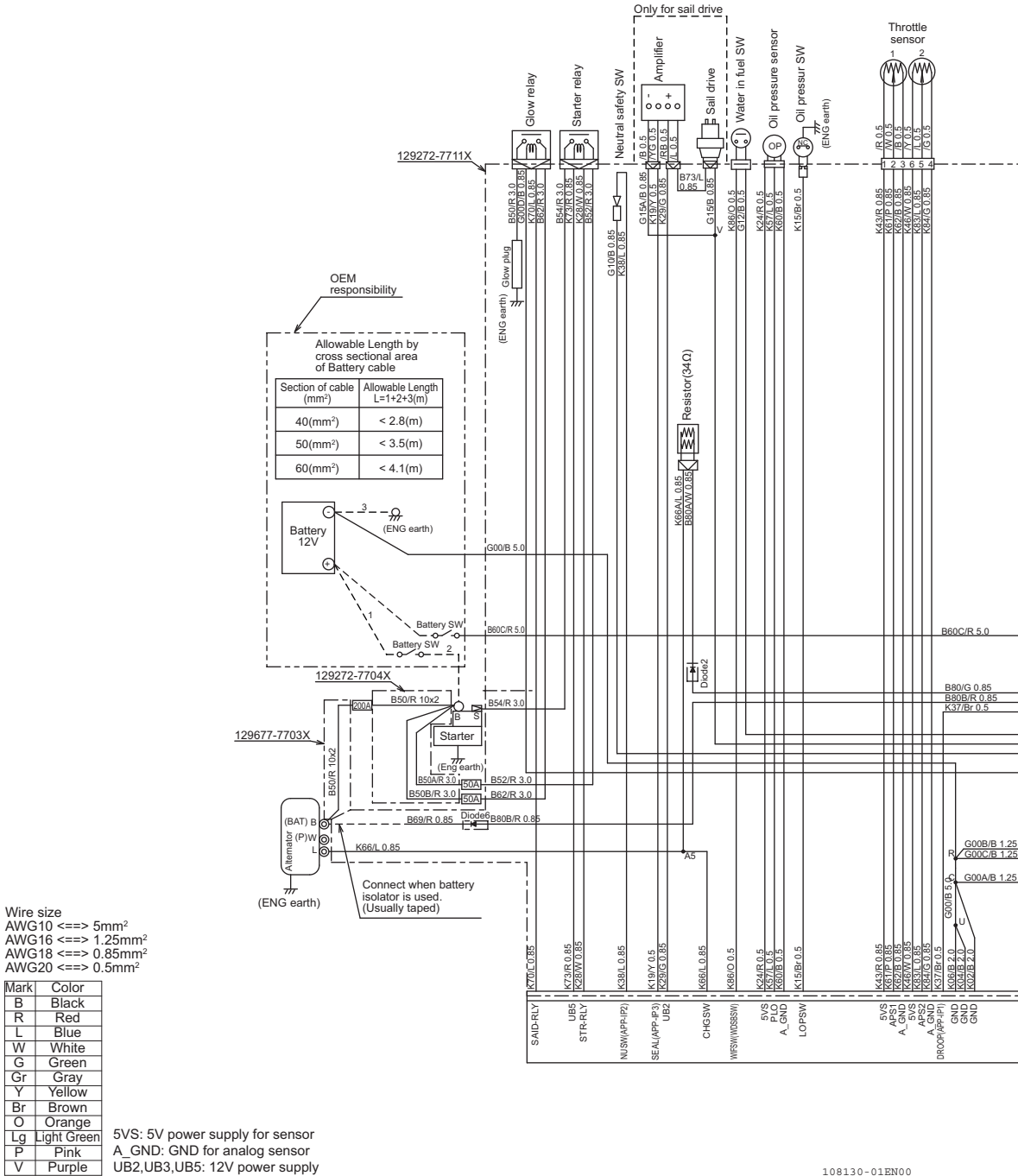

108130-01EN00

Figure 8

Semi 2-pole system (B25,C35-Type instrument panel)

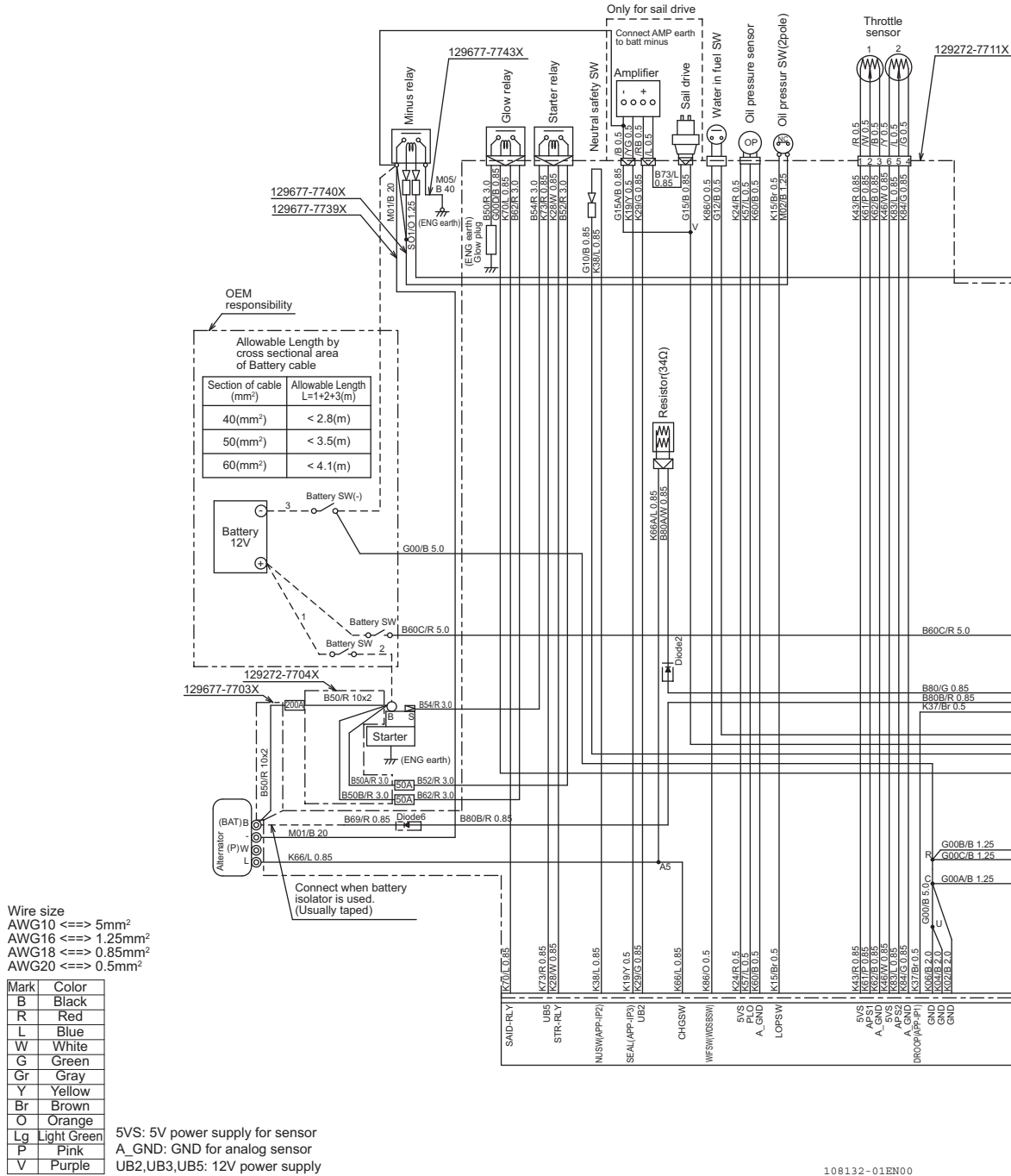

Figure 9

108132-01EN00

VC10 (Vessel control system)

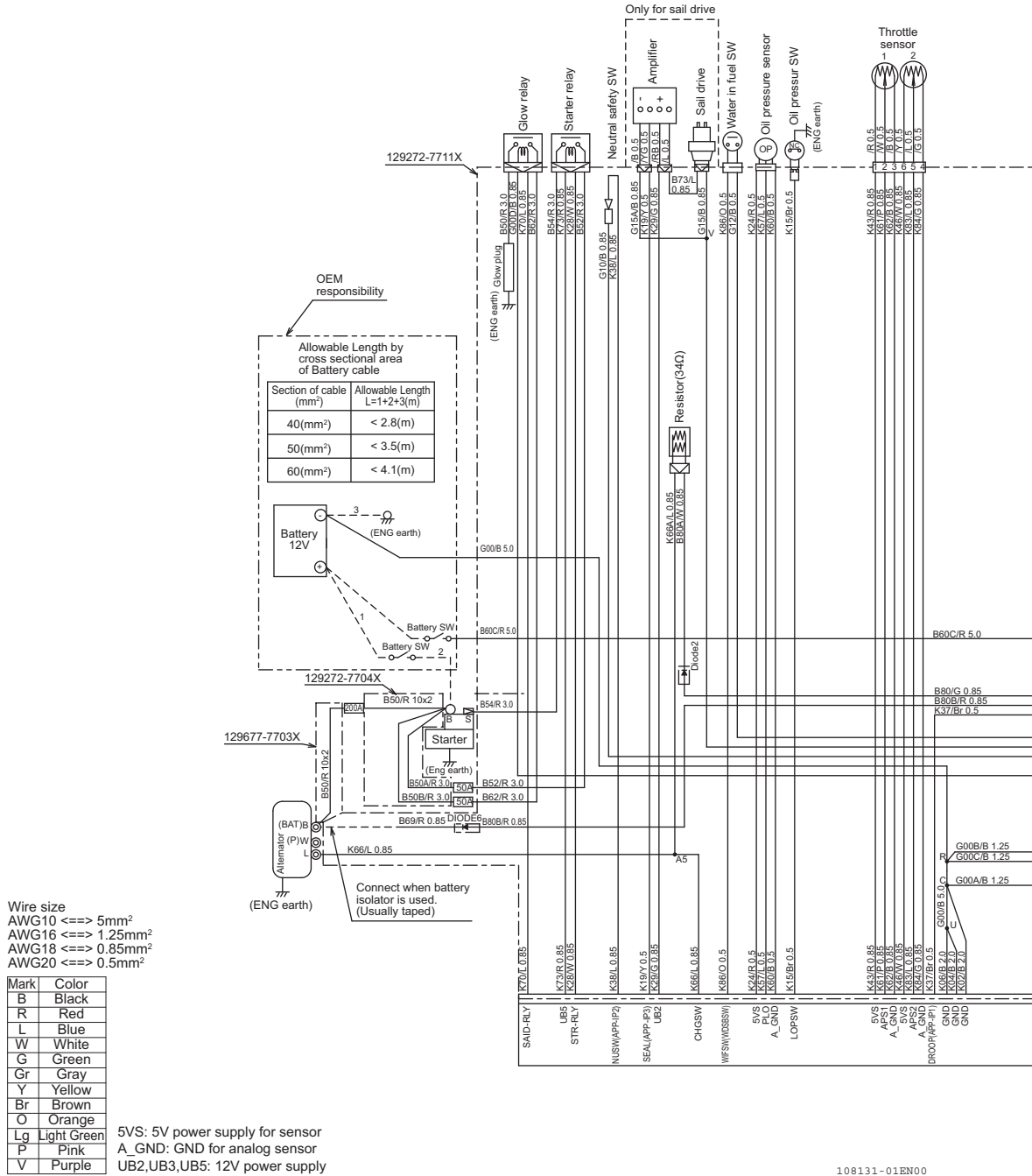

Figure 10

108131-01EN00

Semi 2-pole system VC10 (Vessel control system)

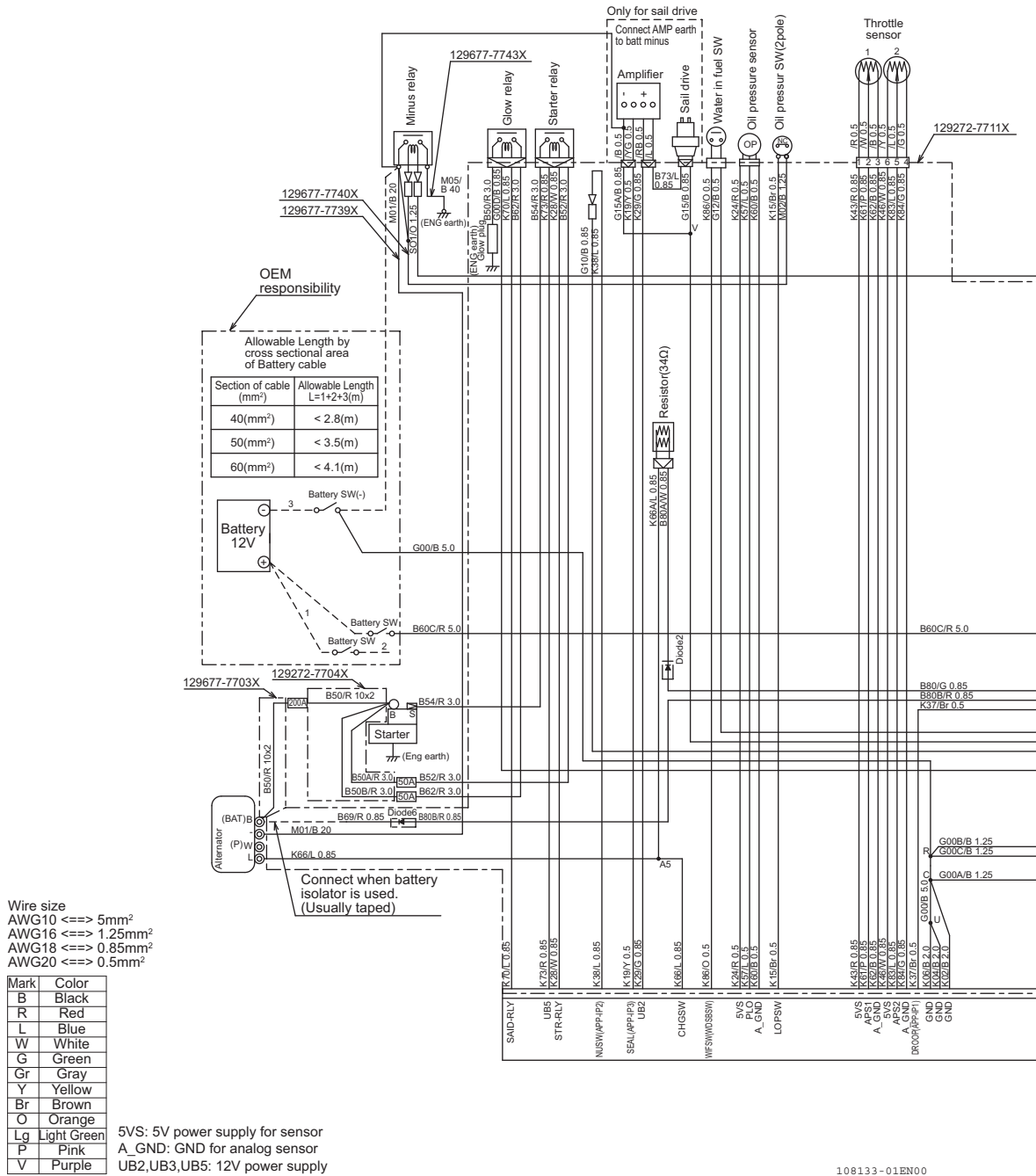

Figure 11

108133-01EN00

SYSTEM DIAGRAMS

4JH45, 4JH57, 4JH80, 4JH110

Standard (B25,C35-Type instrument panel)

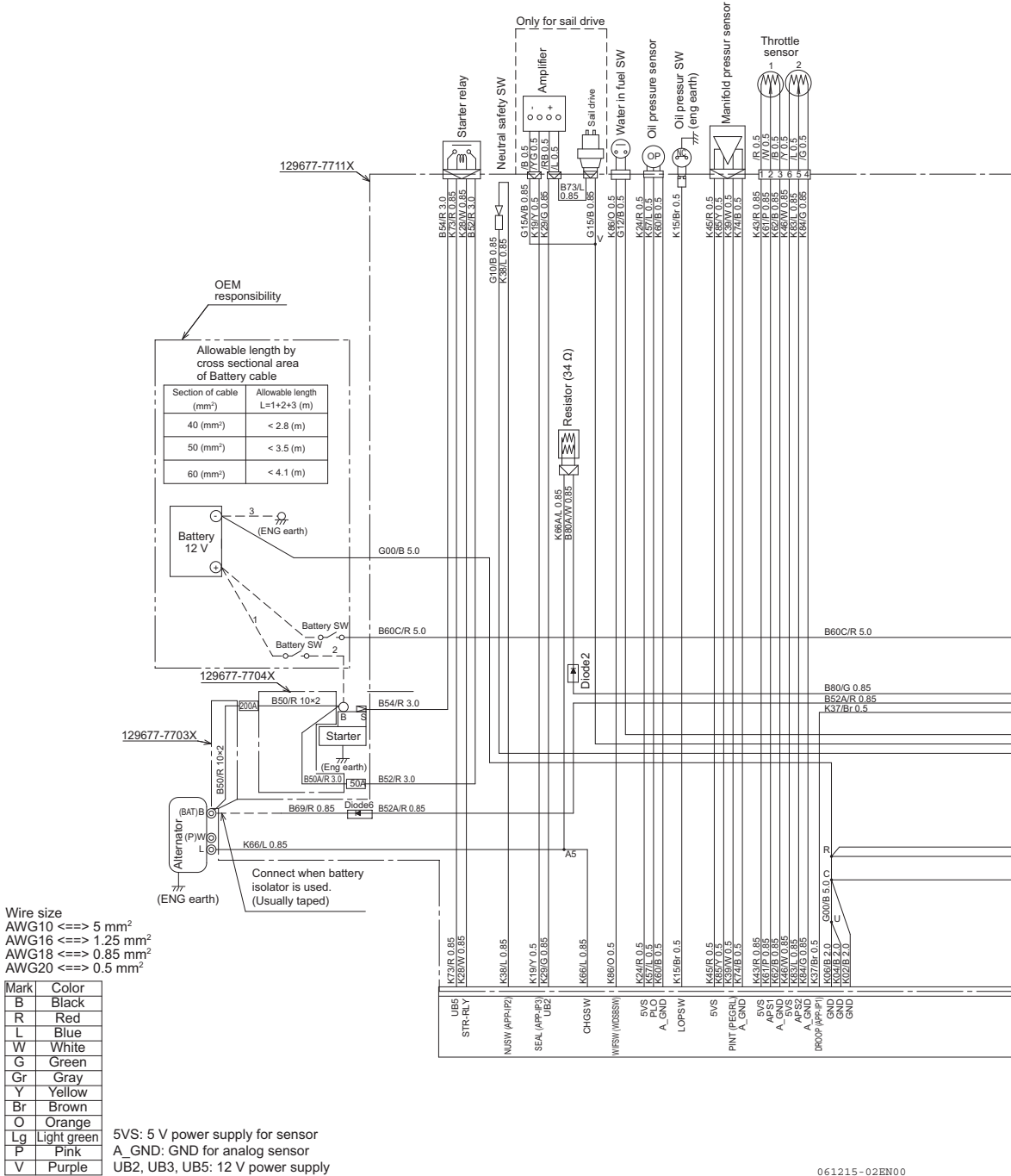
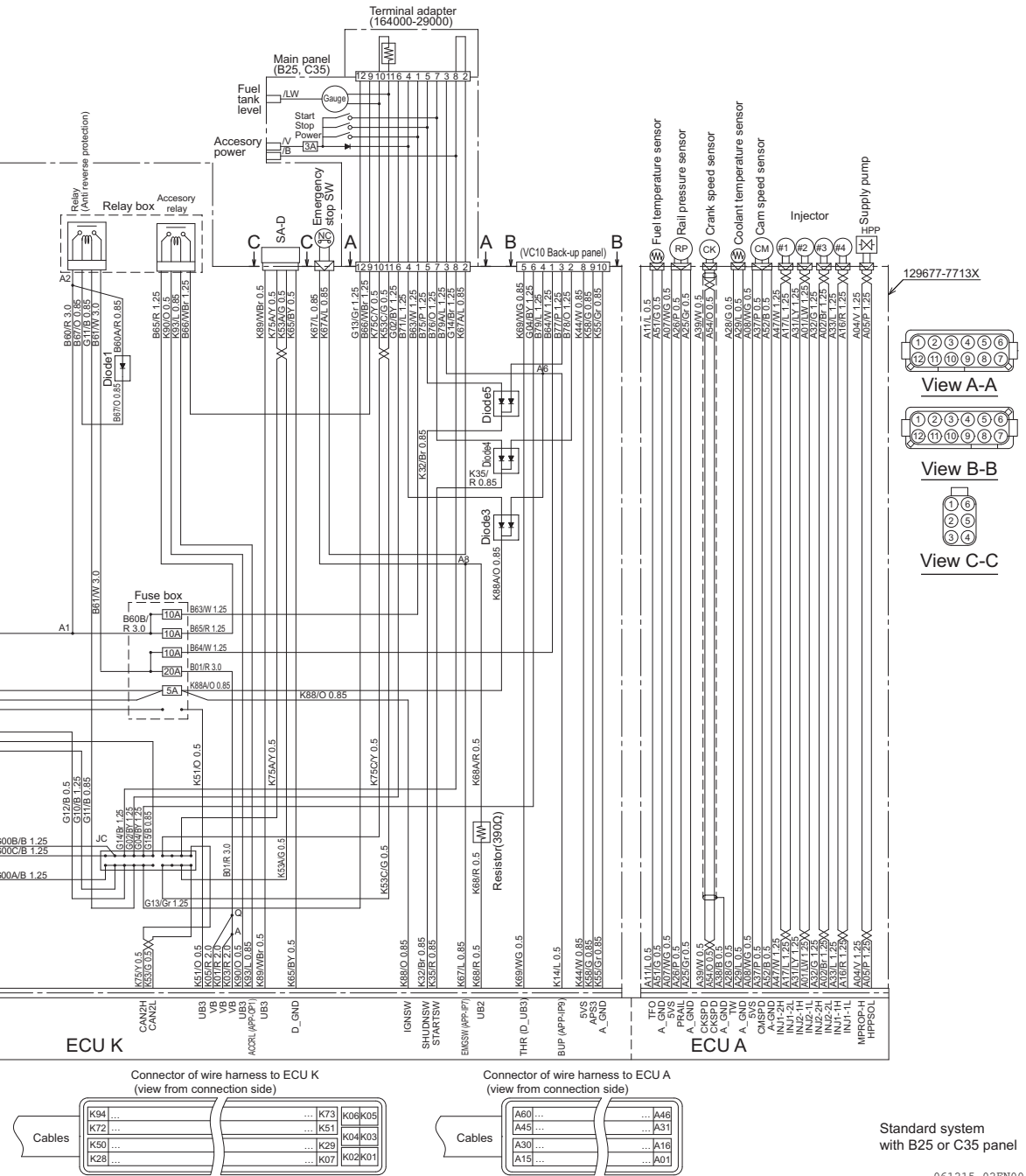

Figure 12

061215-02EN00



061215-02EN00

Semi 2-pole system (B25,C35-Type instrument panel)

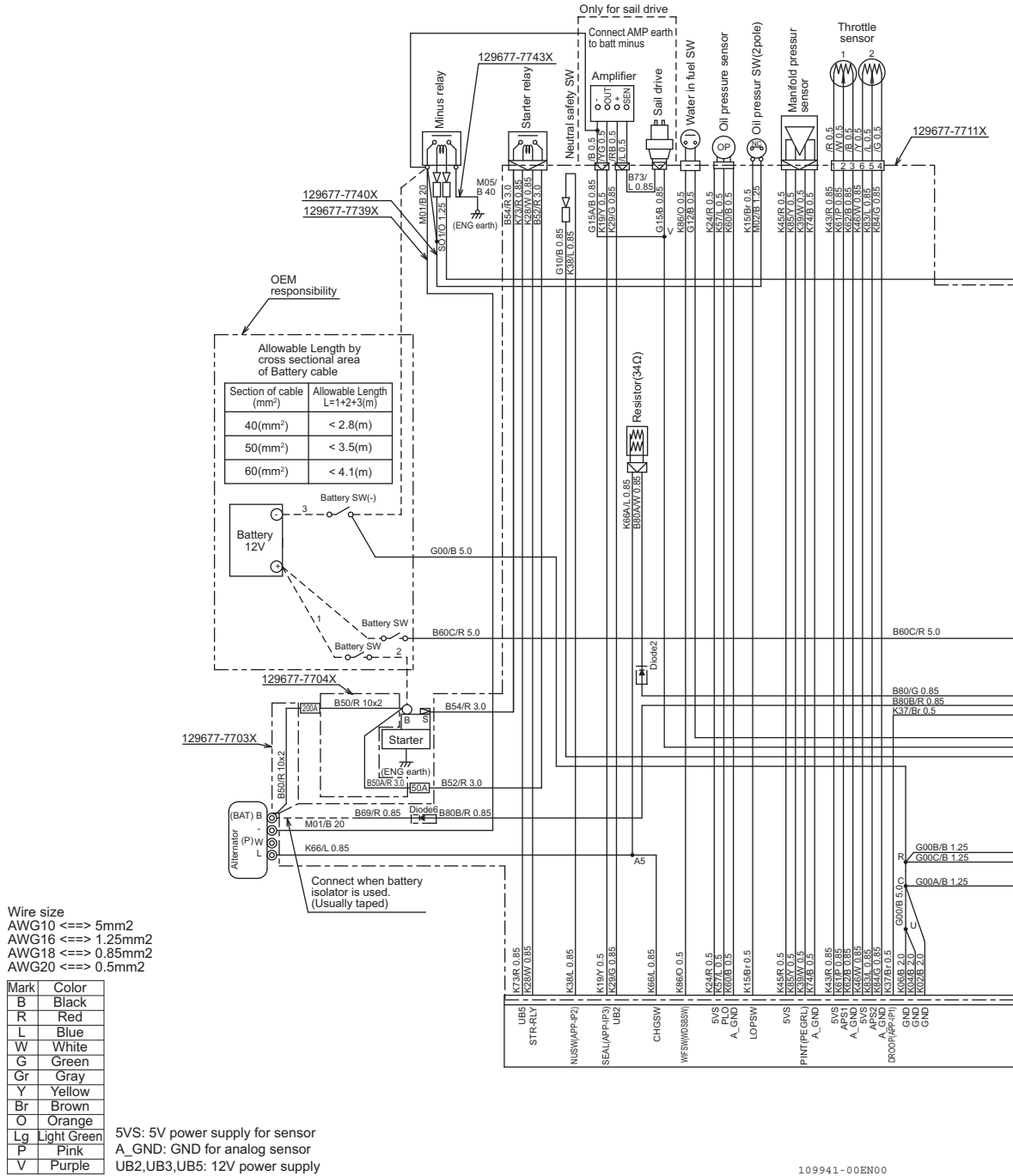

109941-00EN00

Figure 13

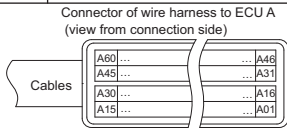
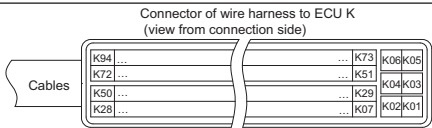
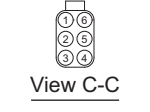
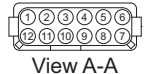
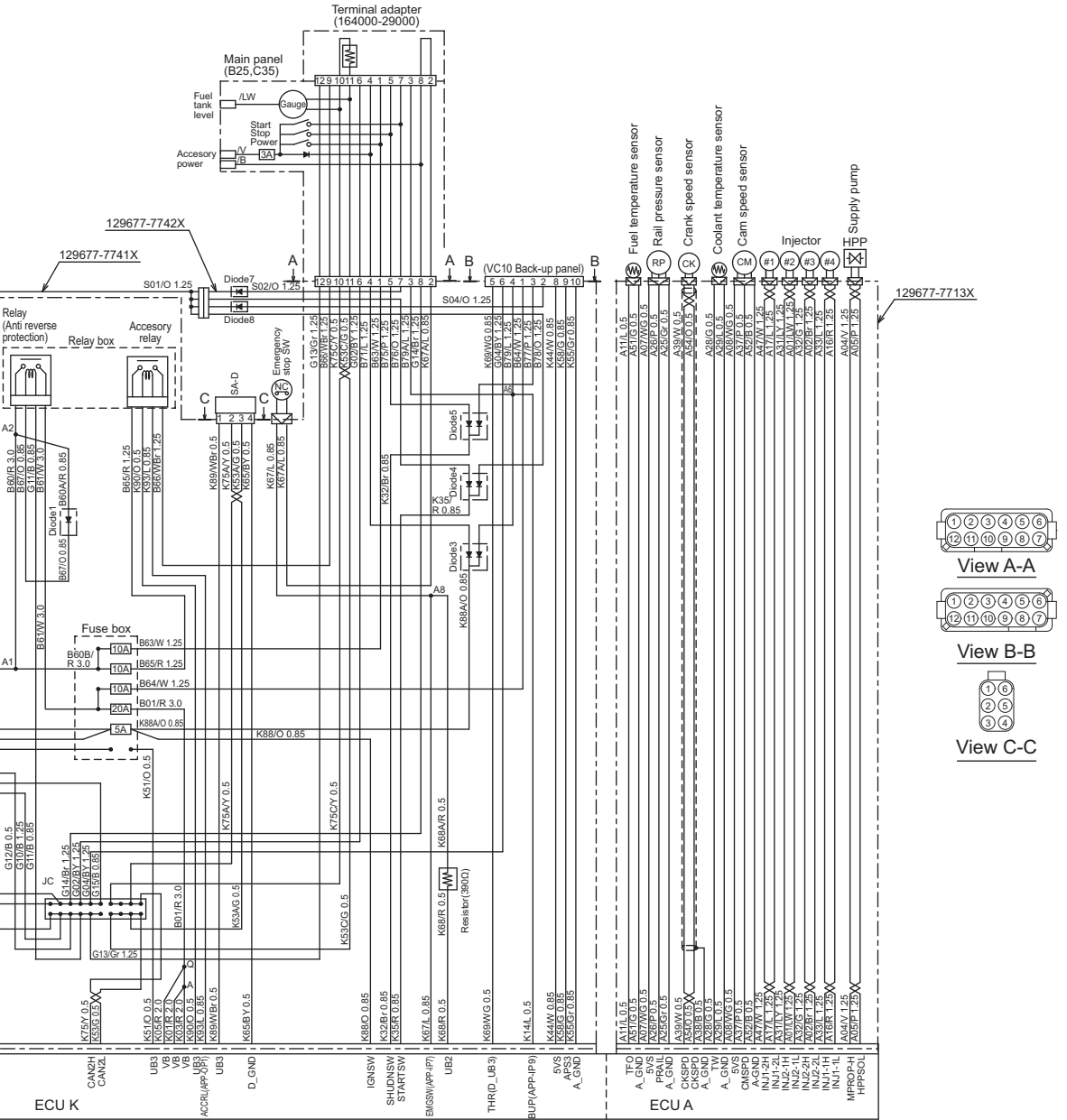

Semi 2pole system with B25 or C35 panel

109941-00EN00

VC10 (Vessel control system)

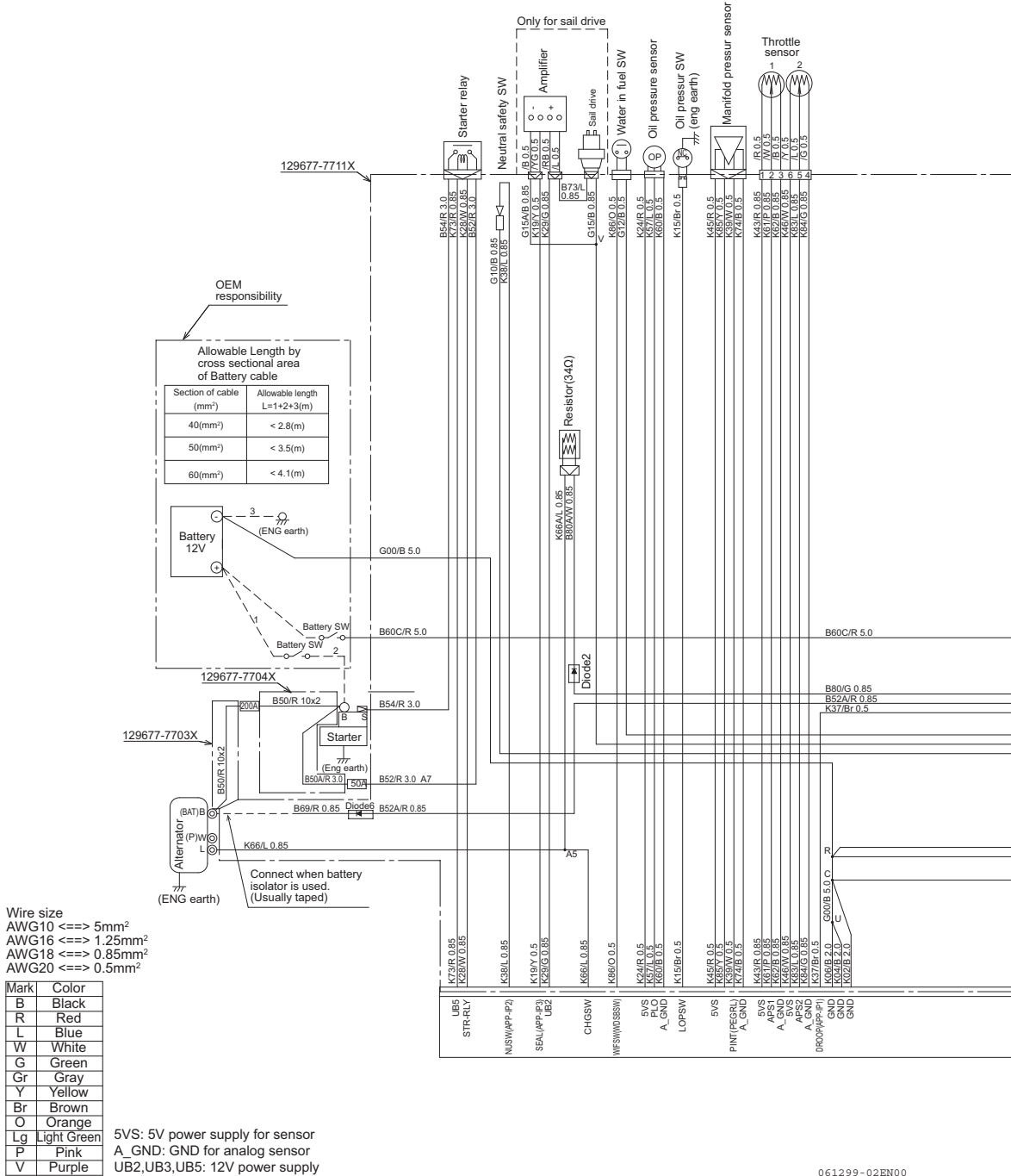

Figure 14

061299-02EN100

Semi 2-pole system VC10 (Vessel control system)

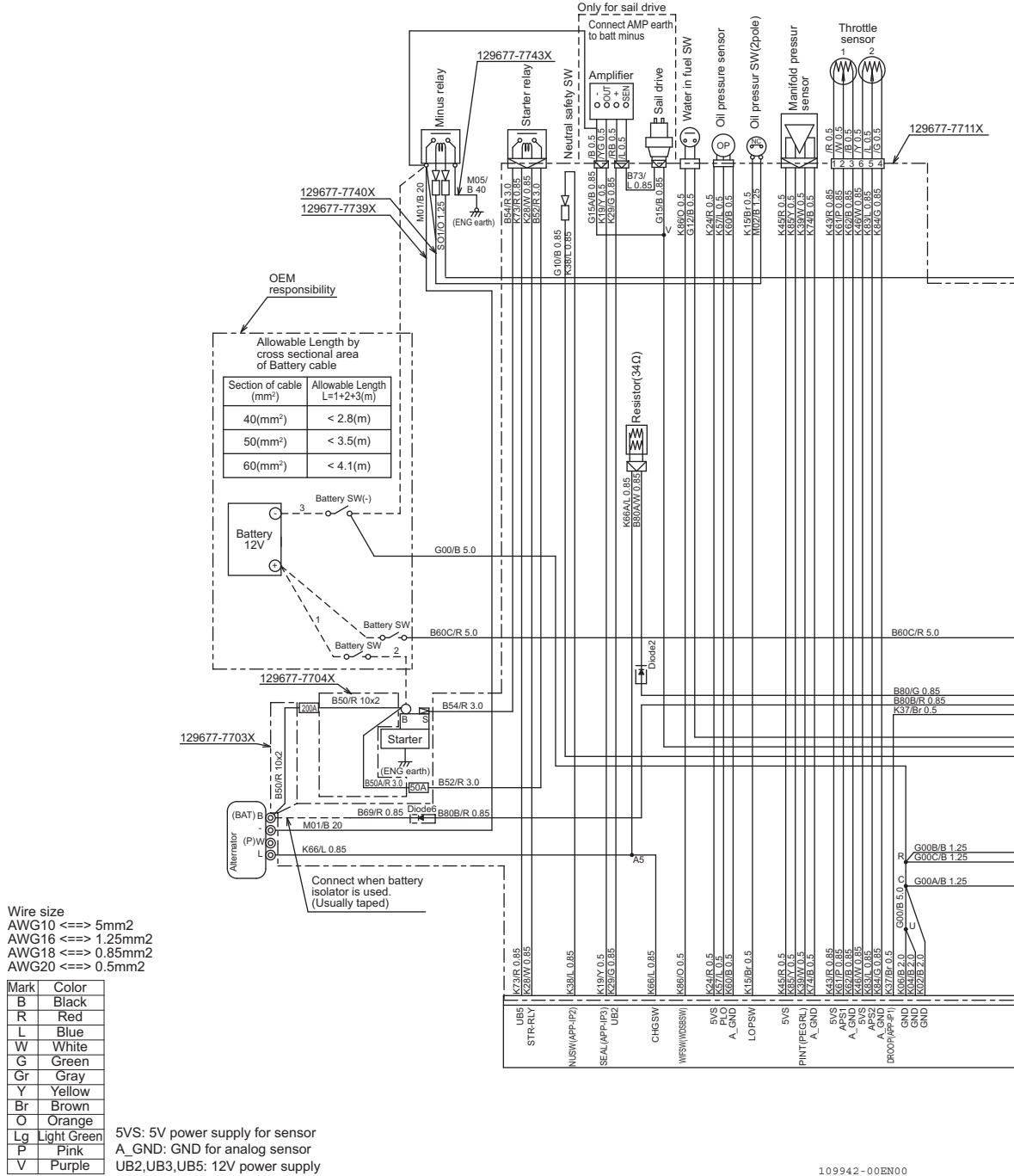
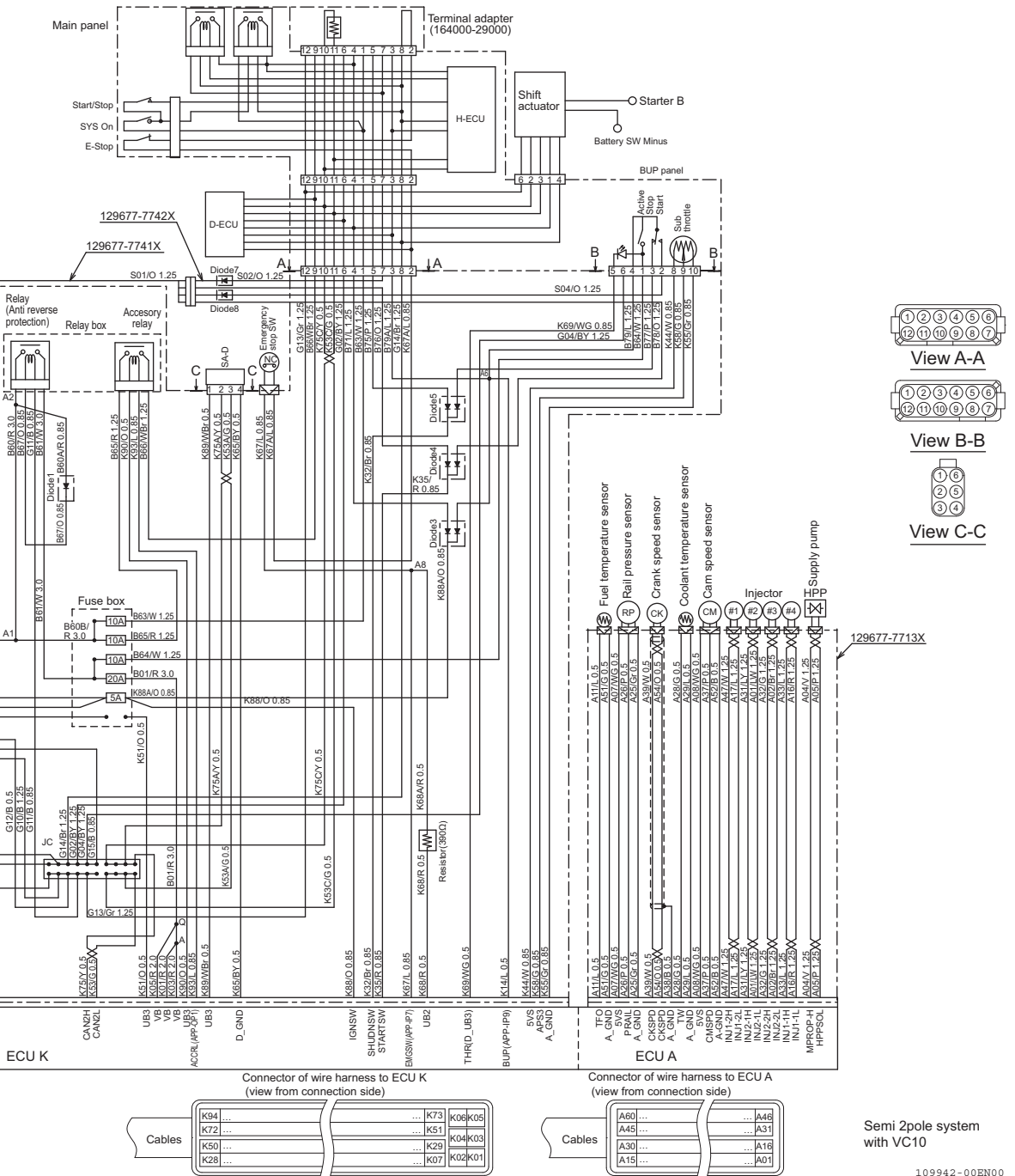

Figure 15

109942-00EN10



This Page Intentionally Left Blank

WARRANTY USA ONLY

YANMAR CO., LTD. LIMITED EMISSION CONTROL SYSTEM WARRANTY - USA ONLY

EPA and ARB Emission Control Label for 3JH40 (kW < 37)

EMISSION CONTROL INFORMATION	
THIS ENGINE COMPLIES WITH U.S.EPA MARINE AND CALIFORNIA OFF-ROAD REGULATIONS FOR 2018 M.Y. DIESEL ENGINES. ULTRA LOW SULFUR DIESEL FUEL ONLY.	
ENGINE FAMILY : JYDXN1.64E3N	DISPLACEMENT : 1.642 LITERS
ENGINE MODEL : 3JH40	E.C.S. : DFI
FUEL RATE : 32.2MM ³ /STROKE @ 29.4kW / 3000RPM (19≤kW<37)	
EPA STANDARDS NOx+HC : 5.8g/kW-hr CO : 5.5g/kW-hr PM : 0.20g/kW-hr	
APPLICATION : VARIABLE-SPEED PROPULSION ENGINES USED WITH FIXED-PITCH PROPELLERS.	
YANMAR YANMAR CO.,LTD.	

129272-07520-J

Figure 1

EPA and ARB Emission Control Label for 4JH45 (kW < 37)

EMISSION CONTROL INFORMATION	
THIS ENGINE COMPLIES WITH U.S.EPA MARINE AND CALIFORNIA OFF-ROAD REGULATIONS FOR 2018 M.Y. DIESEL ENGINES. ULTRA LOW SULFUR DIESEL FUEL ONLY.	
ENGINE FAMILY : JYDXN1.64E3N	DISPLACEMENT : 2.190 LITERS
ENGINE MODEL : 4JH45	E.C.S. : DFI
FUEL RATE : 28.1MM ³ /STROKE @ 33.1kW / 3000RPM (19≤kW<37)	
EPA STANDARDS NOx+HC : 5.8g/kW-hr CO : 5.5g/kW-hr PM : 0.20g/kW-hr	
APPLICATION : VARIABLE-SPEED PROPULSION ENGINES USED WITH FIXED-PITCH PROPELLERS.	
YANMAR YANMAR CO.,LTD.	

129674-07521-J

Figure 2

EPA Emission Control Label for 4JH57

EMISSION CONTROL INFORMATION	
THIS MARINE ENGINE COMPLIES WITH U.S. EPA REGULATIONS FOR 2018 ULTRA LOW SULFUR DIESEL FUEL ONLY.	
ENGINE FAMILY : JYDXN2. 19D4C ENGINE MODEL : 4JH57	
STANDARDS CO : 5.0g/kW-hr PM : 0.20g/kW-hr	
F.E.L. NOx+HC: 5.49/kW-hr	
APPLICATION : VARIABLE-SPEED PROPULSION ENGINES USED WITH FIXED-PITCH PROPELLERS.	
EMISSION CONTROL SYSTEM : DFI	
REFER TO OWNER'S MANUAL FOR MAINTENANCE SPECIFICATIONS AND ADJUSTMENTS.	
YANMAR YANMAR CO., LTD.	

129675-07520-J

Figure 3

EPA Emission Control Label for 4JH110

EMISSION CONTROL INFORMATION	
THIS MARINE ENGINE COMPLIES WITH U.S. EPA REGULATIONS FOR 2018 ULTRA LOW SULFUR DIESEL FUEL ONLY.	
ENGINE FAMILY : JYDXN2. 00D4C ENGINE MODEL : 4JH110	
STANDARDS NOx+HC : 5.8g/kW-hr CO : 5.0g/kW-hr PM : 0.15g/kW-hr	
APPLICATION : VARIABLE-SPEED PROPULSION ENGINES USED WITH FIXED-PITCH PROPELLERS.	
EMISSION CONTROL SYSTEM : DFI	
REFER TO OWNER'S MANUAL FOR MAINTENANCE SPECIFICATIONS AND ADJUSTMENTS.	
YANMAR YANMAR CO., LTD.	

129677-07520-J

Figure 5

EPA Emission Control Label for 4JH80

EMISSION CONTROL INFORMATION	
THIS MARINE ENGINE COMPLIES WITH U.S. EPA REGULATIONS FOR 2018 ULTRA LOW SULFUR DIESEL FUEL ONLY.	
ENGINE FAMILY : JYDXN2. 00E4C ENGINE MODEL : 4JH80	
STANDARDS CO : 5.0g/kW-hr PM : 0.20g/kW-hr	
F.E.L. NOx+HC: 5.49/kW-hr	
APPLICATION : VARIABLE-SPEED PROPULSION ENGINES USED WITH FIXED-PITCH PROPELLERS.	
EMISSION CONTROL SYSTEM : DFI	
REFER TO OWNER'S MANUAL FOR MAINTENANCE SPECIFICATIONS AND ADJUSTMENTS.	
YANMAR YANMAR CO., LTD.	

129676-07520-J

Figure 4

YANMAR EMISSION CONTROL SYSTEM WARRANTY STATEMENT

YOUR WARRANTY RIGHTS AND OBLIGATIONS:

Yanmar Co., Ltd. (Yanmar) is pleased to explain emission control system warranty on your 2018, 2019 or 2020 model year marine compression-ignition (CI) engine. New marine CI engines must be designed, built and equipped to meet stringent anti-smog standards. Yanmar must warrant the emission control system on your marine CI engine for the periods of time listed below provided there has been no abuse, neglect or improper maintenance of your engine.

Your emission control system may include parts such as the fuel injection system, the air induction system and other emission-related assemblies.

Where a warrantable condition exists, Yanmar will repair your marine CI engine at no cost to you including diagnosis, parts and labor.

Yanmar's warranty coverage:

The 2018, 2019 or 2020 model year marine CI engines are covered by the warranty period indicated in a table below.

Engine Model	Warranty Period
3JH40, 4JH45 (19 ≤ kW < 37)	5 years or 3000 hours of use, whichever comes first.
4JH57, 4JH80, 4JH110 (37 ≤ kW)	5 years or 5000 hours of use, whichever comes first.

If any emission-related part on your marine CI engine is found to be defective during the applicable warranty period, the part will be replaced by Yanmar.

When a measurement device of use hours is not equipped, warranties apply a period of use months.

This warranty is transferable to each subsequent purchaser for the duration of the warranty period. Yanmar recommends that repair or replacement of any warranted parts be performed at an authorized Yanmar dealer or distributor.

YANMAR EMISSION CONTROL SYSTEM WARRANTY STATEMENT

Warranted parts not scheduled for replacement as required maintenance in the *Operation Manual* shall be warranted for the warranty period. Warranted parts scheduled for replacement as required maintenance in the operation manual are warranted for the period of time prior to the first scheduled replacement. Any part repaired or replaced under warranty shall be warranted for the remaining warranty period.

During the warranty period, Yanmar is liable for damages to other engine components caused by the failure of any warranted part during the warranty period.

Any replacement part which is functionally identical to the original equipment part in all respects may be used in the maintenance or repair of your engine, and shall not reduce Yanmar's warranty obligations. Add-on modified parts that are not exempted may not be used. The use of any non-exempted add-on or modified parts shall be grounds for disallowing a warranty.

Warranted Parts:

This warranty covers engine components that are a part of the emission control system of the engine as delivered by Yanmar to the original retail purchaser. Such components may include the following:

- Fuel Injection System
- Intake Manifold
- Exhaust Manifold
- Positive Crankcase Ventilation (PCV) System
- Electronic Engine Control Units and its associated Sensor and Actuators

Since emissions-related parts may vary slightly between models, certain models may not contain all of these parts and other models may contain the functional equivalents.

Exclusions:

Failures other than those arising from defects in material and / or workmanship are not covered by this warranty. The warranty does not extend to the following: malfunctions caused by abuse, misuse, improper adjustment, modification, alteration, tampering, disconnection, improper or inadequate maintenance, improper storage or use of non-recommended fuels and lubricating oils; accident-caused damage, and replacement of expendable and / or consumable items made in connection with scheduled maintenance. Yanmar disclaims any responsibility for incidental or consequential damages such as loss of time, inconvenience, loss of use of marine vessel / engine or commercial loss.

Owners Warranty Responsibilities:

- As the marine CI engine owner, you are responsible for the performance of the required maintenance listed in your operation manual. Yanmar recommends that you retain all documentation, including receipts covering maintenance on your marine CI engine, but Yanmar cannot deny warranty solely for the lack of receipts or for your failure to ensure the performance of all scheduled maintenance.
- Your marine CI engine is designed to operate on diesel fuel only. Use of any other fuel may result in your marine CI engine no longer operating in compliance with applicable emission requirements.
- You are responsible for initiating the warranty process. You are responsible for presenting your marine engine to an authorized Yanmar dealer as soon as problem exists.

Customer Assistance:

If you have any questions regarding your warranty rights and responsibilities or would like information on the nearest authorized Yanmar dealer or distributor, you should consult Yanmar America Corporation.

Yanmar America Corporation

Toll free telephone:

1-855-416-7091 or 1-800-872-2867

E-mail: CS_support@yanmar.com

Website: us.yanmar.com

Declaration of Conformity for Recreational Craft Propulsion Engines (inboard engines and stern drive engines without integral exhaust) with the requirements of Directive 2013/53/EU
(To be completed by manufacturer or, if mandated, authorised representative)

Name of engine manufacturer: Yanmar Co., Ltd.

Address: 1-32, Chayamachi, Kita-ku, Osaka

Town: _____ Post Code: 530-8311 Country: Japan

Name of Authorised Representative: Yanmar Marine International B.V.

Address: Brugplein 11

Town: Almere Post Code: 1332 BS Country: the Netherlands

Name of Notified Body for **exhaust emission assessment**: Société Nationale de Certification et d'Homologation

Address: 11, route de Luxembourg

Town: Sandweiler Post Code: L-5230 Country: Luxembourg ID Number: 0499

Conformity assessment module used for exhaust emissions: B+C/C1 B+D B+E B+F G H
or engine type-approved according to: Directive 97/68/EC EC Regulation No 595/2009

Other Community Directives applied: 2014/30/EU

DESCRIPTION OF ENGINE TYPE(s)

Main Propulsion ExhaustType:

- With integral exhaust
 Without integral exhaust

Combustion Type:

- Internal combustion, Diesel (CI)
 Internal combustion, Petrol (SI)
 Other

Combustion cycle:

- 2 stroke
 4 stroke

IDENTIFICATION OF ENGINE(S) COVERED BY THIS DECLARATION OF CONFORMITY

Name of engine model or engine family:	Unique engine identification number(s) or engine family code(s)	EC Type-examination certificate or type-approval certificate number
Engine family: RCD2-2YM15X1 Engine models: 2YM15, 3YM20		SNCH*2013/53*2013/53* 0049*00
Engine family: RCD2-3YM30X1 Engine models: 3YM30AE		0052*00
Engine family: RCD2-3JH5X1 Engine models: 3JH5E, 3JH5AE		0059*00
Engine family: RCD2-4JH57X1 Engine models: 4JH57, 4JH45		0055*00
Engine family: RCD2-4JH11X1 Engine models: 4JH110, 4JH80		0050*00
Engine family: RCD2-3JH40X1 Engine models: 3JH40		0102*00

This declaration of conformity is issued under the sole responsibility of the manufacturer. I declare on behalf of the manufacturer that the recreational craft propulsion engine(s) mentioned above fulfil(s) the requirements specified in Article 4 (1) and Annex I of Directive 2013/53/EU.

Name / function: Shiori Nagata, President
(identification of the person empowered to sign on behalf of the engine manufacturer or his authorised representative)

Signature and title:  President
(or an equivalent marking)

Date and place of issue: (yy/mm/dd) 17/06/06, Yanmar Marine International B.V.

Essential requirements (reference to relevant articles in Annex IB & IC of the Directive)	Harmonised standards Full Application	Harmonised standards Partial application, see tech. file	Other reference documents ¹ Full Application	Other reference documents Partial Application, see tech. file	Other proof of conformity See technical file	Specify the harmonised ² standards or other reference documents used (with year of publication like "EN ISO 8666:2002")
Annex I.A - Design and Construction of products						
Inboard Engine (Annex I A. 5.1.1)	<input type="checkbox"/>	<input type="checkbox"/>	<input type="checkbox"/>	<input type="checkbox"/>	<input type="checkbox"/>	
Ventilation (Annex I A.5.1.2)	<input type="checkbox"/>	<input type="checkbox"/>	<input type="checkbox"/>	<input type="checkbox"/>	<input type="checkbox"/>	
Exposed parts (Annex I A.5.1.3)	<input type="checkbox"/>	<input type="checkbox"/>	<input type="checkbox"/>	<input type="checkbox"/>	<input type="checkbox"/>	
Fuel system - General (Annex I A.5.2.1)	<input type="checkbox"/>	<input type="checkbox"/>	<input type="checkbox"/>	<input type="checkbox"/>	<input type="checkbox"/>	
Electrical System (Annex I A.5.3)	<input type="checkbox"/>	<input type="checkbox"/>	<input type="checkbox"/>	<input type="checkbox"/>	<input type="checkbox"/>	
Steering System (Annex I A.5.4)	<input type="checkbox"/>	<input type="checkbox"/>	<input type="checkbox"/>	<input type="checkbox"/>	<input type="checkbox"/>	
Fire protection - General (Annex I A.5.6.1)	<input type="checkbox"/>	<input type="checkbox"/>	<input type="checkbox"/>	<input type="checkbox"/>	<input type="checkbox"/>	
Discharge prevention (Annex I A.5.8)	<input type="checkbox"/>	<input type="checkbox"/>	<input type="checkbox"/>	<input type="checkbox"/>	<input type="checkbox"/>	
Annex I.B – Exhaust Emissions						
Propulsion Engine Identification (Annex I B.1)	<input type="checkbox"/>	<input type="checkbox"/>	<input type="checkbox"/>	<input type="checkbox"/>	<input type="checkbox"/>	
Exhaust Emission Requirements (Annex I B. 2)	<input checked="" type="checkbox"/>	<input type="checkbox"/>	<input type="checkbox"/>	<input type="checkbox"/>	<input type="checkbox"/>	EN ISO 18854: 2015
Durability (Annex I B.3)	<input type="checkbox"/>	<input type="checkbox"/>	<input type="checkbox"/>	<input type="checkbox"/>	<input type="checkbox"/>	
Owner's manual (Annex I B.4)	<input type="checkbox"/>	<input type="checkbox"/>	<input type="checkbox"/>	<input type="checkbox"/>	<input type="checkbox"/>	
Annex I.C – Noise Emissions	See Declaration of Conformity of the recreational craft in which the engine(s) has (have) been installed					

¹ Such as non-harmonised standards, rules, regulations, guidelines, etc.

² Standards published in EU Official Journal

This Page Intentionally Left Blank

YANMAR CO., LTD.

■ Large Power Products Management Division

Quality Assurance Division

5-3-1, Tsukaguchi-honmachi, Amagasaki
Hyogo, 661-0001, Japan
Phone: +81-6-6428-3137 Fax: +81-6-6421-5549
<https://www.yanmar.com/>

■ Yanmar Marine International B.V.

Brugplein 11, 1332 BS Almere-de Vaart, Netherlands
Phone: +31-36-5493534 Fax: +31-36-5493219
<http://www.yanmarmarine.com/>

Overseas Office

■ Yanmar Europe B.V. (YEU)

Brugplein 11, 1332 BS Almere-de Vaart, Netherlands
Phone: +31-36-5493200 Fax: +31-36-5493209
<http://www.yanmar.com/eu/>

■ Yanmar Asia (Singapore) Corporation Pte. Ltd. (YASC)

4 Tuas Lane, Singapore 638613
Phone: +65-6861-3855 Fax: +65-6862-5189
<https://www.yanmar.com/sg/>

■ Yanmar America Corporation (YA)

101 International Parkway,
Adairsville, GA 30103, U.S.A.
Phone: +1-770-877-9894 Fax: +1-770-877-9009
<http://www.yanmar.com/us/>

■ Yanmar Engine (Shanghai) Co., Ltd.

10F, E-Block Poly Plaza, No.18 Dongfang Road,
Pudong Shanghai, China P.R.C. 200120
Phone: +86-21-6880-5090 Fax: +86-21-6880-8090
<https://www.yanmar.com/cn/>

As of November 1st, 2017

OPERATION MANUAL

3JH40, 4JH45, 4JH57, 4JH80, 4JH110

1st edition: October 2013
2nd edition: June 2014
3rd edition: September 2015
4th edition: January 2017
5th edition: November 2017

Issued by: YANMAR CO., LTD. Large Power Products Management Division

Edited by: YANMAR TECHNICAL SERVICE CO., LTD.

YANMAR

YANMAR CO., LTD.

<https://www.yanmar.com>

0AJHC-EN0014
29.11(YTSK)